

propshaft arrangement by way of example

* Detailed views of body mounting brackets see MBAS-Web catalogues
 -> further information -> additional information
 (https://bb-portal.mercedes-benz.com/portal/produktinformationen.html)

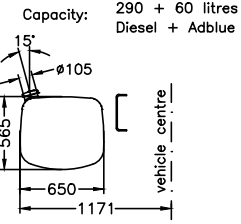
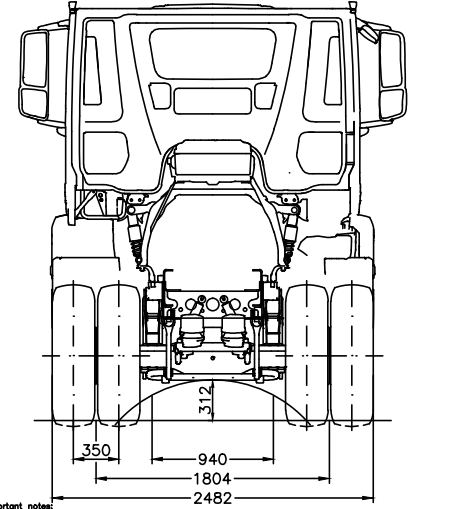
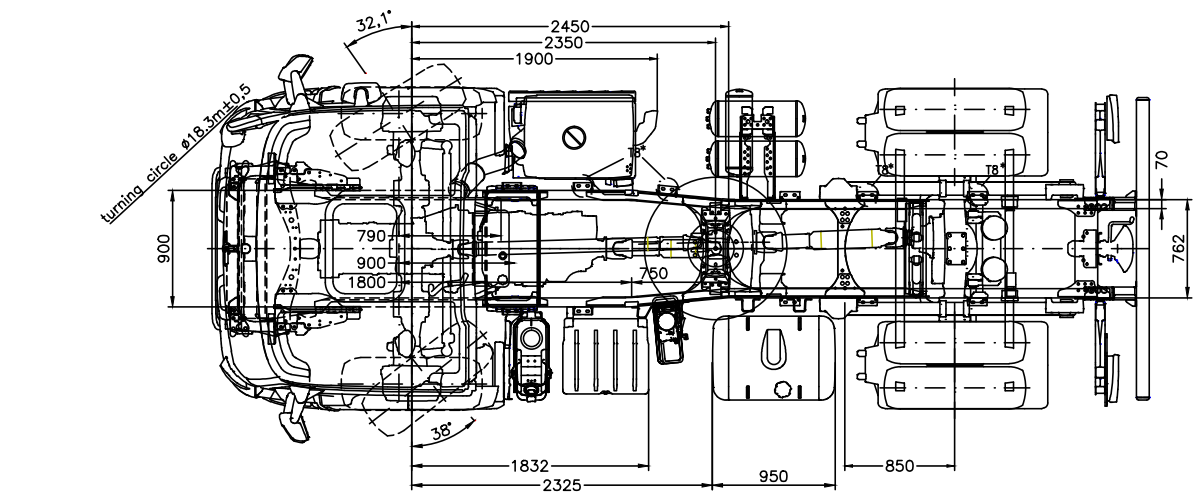
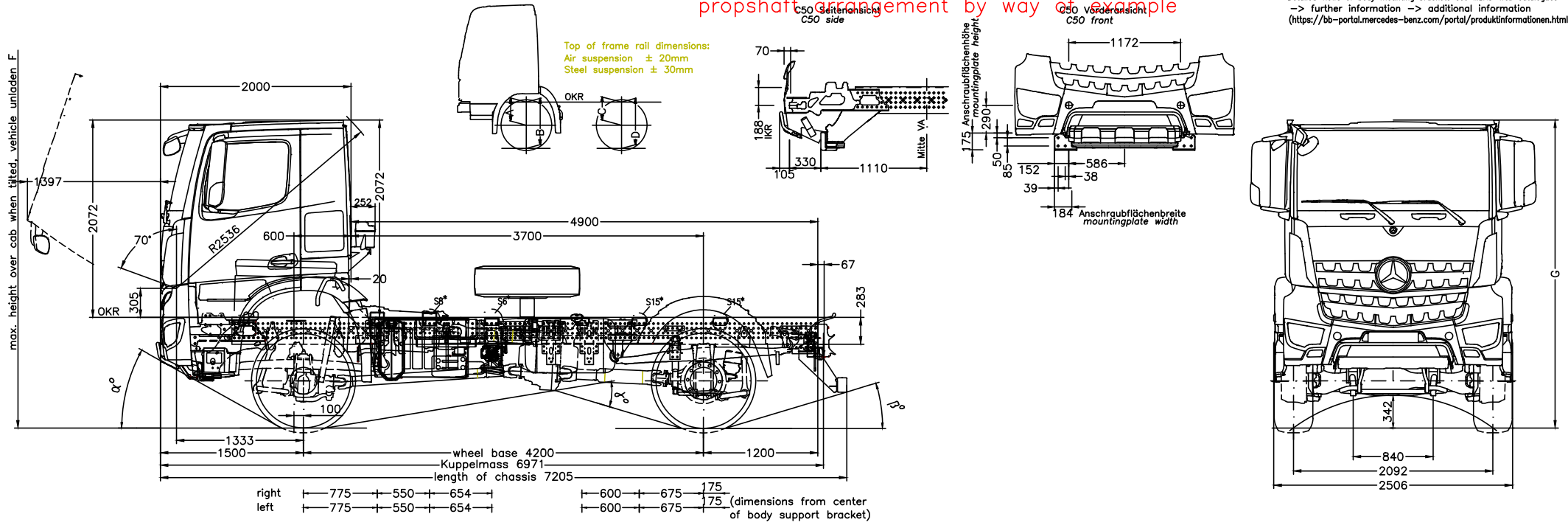

- A1E Front axle 9.0 t
- A1Y Front axle, straight version
- A20 Rear axle, crown wheel 300, planetary, 13.4 t
- B10 Electronic oil-processing unit, mudflap
- S20 Iron brake on front and rear axle
- B4E Air reservoir, steel
- CU1 Frame overhang 1500 mm
- CU2 Wheelbase 4200 mm
- CU3 Mounting points for upper
- CU0 Preparation for special front-mounted equipment
- C6E Power steering pump, uncontrolled
- C6L Power-assisted steering, reinforced, from 9 t
- C6F Shock absorber, under frame, rear axle
- C7A Rear underbody guard (UG2)
- C31 Battery carrier, ballast side by side
- C6F Wheel, for chassis transit
- FIN B-cab CompactSpace, 3.20 m, tunnel 320 mm
- FN1 Cab, 600 mm attachment height
- F71 Cab extension, left/right, movable
- C10 Transmission G 230-14/14.2-0.43
- G4E Transfer case VG 3000-3W, 1.04, engageable
- K2V AdBlue tank, 80 l, left
- K24 Tank, 200 l, left, 800 x 565 x 850 mm, steel
- K70 Exhaust system, tailpipe to right and outside
- M20 Valve suspension in accordance with ECE
- M22 Eng. OM470, inline 6, 10.7 l, 200kW (280hp), 1900 km
- M24 Engine version Euro VI, with OBD-C
- Q11 Overhead door, bumper
- M8A Air intake from front
- V12 Standard
- Z11 E-APU, knee
- Z2E Power take-off, pump, under top edge of frame
- G2U Rear spring, 15.0 t
- G2V Centre-axle trailer coupling, 200, Ringfeder
- Q8E End crossmember lower, reinforced
- RCZ Wheel-nut cap
- R10 15-degree tapered rim, 9.00 x 22.5
- R11 15-degree tapered rim, 11.75 x 22.5, front axle
- R8F Spare wheel carrier, protruding
- V18 Standard

Important notes:
 - Depending on the tire manufacturer the given static loaded radius R stat may vary.
 - It is the responsibility of the bodybuilder to ensure that the vehicle is suitable for homologation after the body has been mounted.
 - The drawing is simplified to some extent and is not legally binding. For more details and further explanations please see the Technical User Guide in the bodybuilder portal.
 - Please check whether the drawing specification complies with the chassis configuration of your order.
 - Optional equipment codes not listed here, CTT codes and changes resulting from feasibility checks (EBA) are not included in the drawing.

Vehicle type	Projection over top of frame	frame side member	A		B		M		N		C		D		E		F		G		Q		R		S	
			loden	loden	loden	loden	loden	loden	loden	loden	loden	loden	loden	loden	loden	loden	loden	loden	loden	loden	loden	loden	loden	loden	loden	loden
96420712		SE00MC	666	1161	1252	-	-	-	-	-	667	567	522	1167	1299	-	-	4093	3324	29	17	26				
1. 385/65R22.5	485	-	-	-	-	-	-	-	-	-	-	-	-	-	-	-	-	-	-	-	-	-	-	-	-	-
2. 315/80R22.5	500	-	-	-	-	-	-	-	-	-	-	-	-	-	-	-	-	-	-	-	-	-	-	-	-	-
4.	-	-	-	-	-	-	-	-	-	-	-	-	-	-	-	-	-	-	-	-	-	-	-	-	-	-

Dimensions are subject to a tolerance of up to +/- 3%

Measurements of load vehicle:
 Our body / equipment mounting brackets must be observed.
 When planning to fit bodies of other than Mercedes-Benz manufacture.

Subject to change.

14.03.18/04mler/ko
 70546 Stuttgart

Mercedes-Benz
 HVA 9630110907