



## KUPNÍ SMLOUVA

na monitorovací vůz pro terénní měření při radiční mimořádné události  
uzavřená níže uvedeného dne, měsíce a roku v souladu s ustanovením § 2079 a násl. zákona  
č. 89/2012 Sb., občanský zákoník, ve znění pozdějších předpisů (dále jen „OZ“)  
(dále jen „Smlouva“)

### Smluvní strany

kupující: **Státní ústav radiální ochrany, v.v.i.**  
Sídlo: Bartoškova 1450/28, 140 00 Praha 4  
IČO: 86652052  
DIČ: CZ86652052  
zastoupená: Mgr. Aleš Froňka, Ph.D., ředitel  
bankovní spojení: Komerční banka a.s.  
číslo účtu: 43-8473960227/0100  
ID datové schránky: fyy5d7d

(dále jen „Kupující“) a

prodávající: **NUVIA a.s.**  
Sídlo: Hrotopická-Průmyslová Zóna 168, 674 01 Střítež  
Jednatel/Zastoupen: IČO: Martin Pazúr, předseda představenstva  
25506331  
DIČ: CZ25506331  
bankovní spojení: KB, a. s.  
číslo účtu: 6618440267/0100  
ID datové schránky: f5vdw92

(dále jen „Prodávající“)

Kupující a Prodávající dále též samostatně jako „Smluvní strana“, nebo společně jako „Smluvní strany“.

### Preambule

- (A) Prodávající tímto prohlašuje, že má veškerá práva, živnostenská oprávnění, zkušenosti, kapacity a odbornou znalost a způsobilost k tomu, aby plnil závazky vyplývající z této Smlouvy a že neexistují žádné právní překážky, které by bránily, či omezovaly plnění jeho závazků a že uzavřením Smlouvy nedojde k porušení žádného obecně závazného předpisu.
- (B) Prodávající současně prohlašuje, že se dostatečným způsobem seznámil s předmětem této Smlouvy, s jejím rozsahem a povahou, s technickými kvalitativními podmínkami a dalšími podmínkami provádění, a že na základě tohoto zjištění je schopný předmět Smlouvy provést v souladu s podmínkami této Smlouvy za sjednanou cenu v požadované lhůtě a kvalitě, aniž by splnění svého závazku podmiňoval poskytnutím jiné než dohodnuté součinnosti Kupujícího nebo dalších subjektů.
- (C) Účelem této Smlouvy je dodávka 1 ks monitorovacího vozu pro terénní měření při radiční mimořádné události.

### I. Předmět Smlouvy

- 1.1. Tato Smlouva je uzavírána na základě výsledku zadávacího řízení na plnění nadlimitní veřejné zakázky „**Dodávka monitorovacího vozu II**“ (dále také jen „**zadávací řízení**“) a v souladu s nabídkou prodávajícího učiněnou v rámci zadávacího řízení. Prodávající je po celou dobu účinnosti Smlouvy vázán svou nabídkou podanou v zadávacím řízení.
- 1.2. Prodávající se zavazuje odevzdat kupujícímu 1 ks monitorovacího vozu pro terénní měření při radiční mimořádné události. Vozidlo bude vybaveno pro měření dávkových příkonů za jízdy, vyhledávání hot spotů při radičních nehodách i zneužití zdrojů ionizujícího záření (včetně špinavé či jaderné bomby) a k rychlé



kvalitativní i kvantitativní analýze vzorků životního prostředí. (dále také jen „Monitorovací vůz“ nebo „předmět koupě“). Součástí dodávky je i provedení zaškolení osob. Bližší specifikace Monitorovacího vozu včetně příslušenství je uvedena v Příloze č. 1 Smlouvy – Technická specifikace.

- 1.3. Kupující se zavazuje řádně dodaný Monitorovací vůz převzít a zaplatit Prodávajícímu kupní cenu sjednanou v čl. II. této Smlouvy.

## II. Kupní cena a místo plnění

- 2.1. Kupní cena za předmět koupě je stanovena na základě nabídky Prodávajícího a dohody Smluvních stran v nepřekročitelné výši **10 810 014,00 CZK bez DPH** (slovy: deset milionů osm set deset tisíc čtrnáct korun korun českých bez daně z přidané hodnoty).  
Cena včetně DPH činí **13 080 117,00 CZK**.

Kupní cena je stanovena jako cena maximální a nejvýše přípustná za předmět Smlouvy. Jediným důvodem pro změnu ceny včetně DPH je změna zákonné sazby DPH. Prodávající odpovídá za to, že sazba DPH bude stanovena v souladu s obecně závaznými právními předpisy České republiky platnými a účinnými v okamžiku zdanitelného plnění.

- 2.2. Kupní cena zahrnuje veškeré náklady nezbytné k řádnému, úplnému a kvalitnímu plnění předmětu Smlouvy Prodávajícím včetně všech rizik a vlivů vyplývajících pro něj v souvislosti s plněním předmětu Smlouvy, tedy veškeré náklady Prodávajícího spojené s dodáním předmětu koupě, zejména dodáním předmětu koupě do místa dodání a jeho odevzdáním Kupujícímu (včetně dokladů), jedná se zejména o náklady na dopravu předmětu koupě, případné celní či jiné poplatky, náklady spojené se zprovozněním předmětu koupě a zaškolením osob určených kupujícími, veškeré přímé či nepřímé náklady spojené s realizací předmětu smlouvy, náklady, o kterých Prodávající v době uzavření smlouvy s ohledem na předmět svého podnikání věděl, nebo vědět měl a mohl, a dále zahrnuje všechna související rizika.
- 2.3. Místem plnění předmětu této Smlouvy je sídlo Kupujícího, tj. Bartoškova 1450/28, 140 00 Praha 4.

## III. Dodání a převzetí předmětu koupě, konzultace

- 3.1. Prodávající je povinen dodat Monitorovací vůz do místa plnění **do 30. 11. 2026**.
- 3.2. O datu doručení Monitorovacího vozu do místa plnění musí Prodávající Kupujícího předem (alespoň 5 pracovní dnů) písemně vyrozumět, a to e-mailem zasláným kontaktní osobě/osobám Kupujícího uvedené v čl. 8.88. této Smlouvy.
- 3.3. Prodávající se zavazuje před dnem doručení Monitorovacího vozu provést kontrolní vážení jeho celkové hmotnosti na certifikované váze splňující požadavky dle bodu 3.1.2 druhového seznamu stanovených měřidel přílohy vyhlášky č. 345/2002 Sb. Kontrolní vážení bude provedeno na náklady prodávajícího za účelem ověření splnění podmínky nepřekročení celkové hmotnosti  
3 300 kg pro Monitorovací vůz včetně zástavby a vybavení specifikovaného v Příloze č. 1 - Technické specifikaci. Prodávající je povinen nejméně 3 pracovní dny před provedením kontrolního vážení písemně vyrozumět kontaktní osobu kupujícího uvedenou v čl. 8.8 této smlouvy o místě a času jeho provedení, přičemž zástupce kupujícího je oprávněn být přítomen jeho provedení. Kupující je oprávněn vyslat svého zástupce k účasti na kontrolním vážení. Kontrolní vážení bude provedeno na území hlavního města Prahy. O provedeném kontrolním vážení bude vyhotoven protokol nebo jiný písemný záznam prokazující skutečnou celkovou hmotnost Monitorovacího vozu včetně příslušenství. V případě, že kontrolní vážení prokáže celkovou hmotnost Monitorovacího vozu převyšující 3 300 kg, není kupující povinen předmět koupě převzít a vzniká mu právo od této smlouvy odstoupit.
- 3.4. Spolu s předmětem koupě je Prodávající povinen dodat veškeré doklady nutné k převzetí a řádnému užívání Monitorovacího vozu odpovídající jeho charakteru a účelu (např. technická dokumentace, návody k obsluze



a údržbě, certifikáty aj.).

- 3.5. Prodávající prohlašuje, že předmět koupě splňuje náležitosti zákona č. 22/1997 Sb., o technických požadavcích na výrobky a o změně a doplnění některých zákonů, ve znění pozdějších předpisů a že Monitorovací vůz je nový, bezvadný, splňuje ustanovení zákona č. 56/2001 Sb., o podmínkách provozu na pozemních komunikacích, ve znění pozdějších předpisů.
- 3.6. Prodávající odevzdá předmět koupě Kupujícímu a Kupující předmět koupě od Prodávajícího převezme. Kupující je oprávněn odmítnout převzít předmět koupě, pokud bude mít vady (i v dokladech). K předání předmětu koupě dojde podepsáním předávacího protokolu (dodacího listu) oběma Smluvními stranami, který bude ve dvou vyhotoveních. Kopie předávacího protokolu bude přílohou daňového dokladu - faktury.
- 3.7. Kupující potvrdí Prodávajícímu převzetí řádně předaného plnění podpisem na předávacím protokolu. Smluvní strany do předávacího protokolu uvedou sjednané datum zaškolení osob určených Kupujícím, nebylo-li ke dni podpisu předávacího protokolu provedeno. Kupující je oprávněn, ne však povinen, převzít plnění i s drobnými vadami, které nebrání jeho užívání. V takovém případě Kupující stanoví lhůtu pro odstranění každé v protokolu uvedené vady.
- 3.8. Vlastnické právo k předmětu koupě a nebezpečí škody na věci přechází na Kupujícího okamžikem převzetí předmětu koupě Kupujícím.
- 3.9. Před zahájením výroby zástavby je Prodávající povinen konzultovat s Kupujícím rozmístění všech prvků účelové zástavby a příslušenství, které bude provedeno dle nákresu uvedeného v příloze č. 1 Smlouvy – Technické specifikaci. Kupující si vyhrazuje právo odsouhlasit konečné rozmístění všech prvků účelové zástavby a příslušenství a Kupující se zavazuje toto respektovat.

#### IV. Platební podmínky

- 4.1. Kupující nebude Prodávajícímu poskytovat žádné zálohy.
- 4.2. Kupní cena bude uhrazena na základě vystaveného daňového dokladu – faktury. Prodávající je oprávněn vystavit fakturu až po řádném dodání předmětu koupě dle této Smlouvy. Přílohou faktury musí být podepsaný předávací protokol dle čl. 3.7 této Smlouvy.
- 4.3. Splatnost faktury činí 30 dní od data jeho doručení Kupujícímu na e-mail sekretariat@suro.cz nebo do datové schránky. Faktura musí mít náležitosti daňového dokladu dle zákona č. 235/2004 Sb., o dani z přidané hodnoty, ve znění pozdějších předpisů (dále jen „zákon o DPH“), zákona č. 563/1991 Sb., o účetnictví, ve znění pozdějších předpisů a obchodní listiny dle ustanovení § 435 OZ.
- 4.4. Pokud faktura nebude obsahovat všechny požadované náležitosti, může ji Kupující vrátit ve lhůtě splatnosti k opravě nebo doplnění, aniž se dostane do prodlení se zaplacením fakturované částky. Doručením opraveného nebo doplněného dokladu počne běžet nová 30denní lhůta splatnosti. Pokud Kupující uplatní nárok na odstranění vady zboží ve lhůtě splatnosti faktury, není povinen až do jejího odstranění uhradit cenu vadného zboží. Okamžikem odstranění vady zboží začne běžet nová lhůta splatnosti faktury v původní délce.
- 4.5. Daň z přidané hodnoty bude účtována a fakturována ve výši a sazbě dle obecně závazných právních předpisů České republiky platných a účinných v okamžiku zdanitelného plnění
- 4.6. Faktura se považuje za uhrazenou dnem odepsání fakturované částky z účtu Kupujícího.

#### V. Vlastnosti předmětu koupě, práva z vadného plnění a záruka

- 5.1. Předmět koupě bude nový, nepoužitý, bez jakýchkoliv faktických a právních vad, bude mít ujednané vlastnosti (zejména druh, typ, množství, jakost a provedení), bude plně způsobilý k účelu uvedenému ve smlouvě, jinak k účelu obvyklému, a bude mít rovněž vlastnosti, stanovené obecně závaznými právními



předpisy České republiky a platnými technickými a jinými normami (zejména ČSN a ČSN EN), zabezpečující řádné užívání, a to včetně vlastností příslušenství.

- 5.2. Plnění má vady, nebylo-li odevzdané Kupujícímu v ujednaném množství, jakosti a provedení. Za vadu se považuje i vada v dokladech nutných pro užívání věci.
- 5.3. Vady zjištěné při převzetí předmětu koupě anebo v záruční době je prodávající povinen bezúplatně odstranit do 30 dnů ode dne jejich písemného oznámení Kupujícím, nedohodnou-li se na jiné lhůtě, a to i v případech, kdy Prodávající neuznává, že za vadu odpovídá. Pokud tak v této lhůtě Prodávající neprovede, má Kupující právo, bez ztráty záruk, zadat odstranění vad jinému subjektu, či provést odstranění vad svépomocí a prodávající je povinen tyto náklady neprodleně uhradit. Pokud Prodávající prokáže, že za vady neodpovídá, budou mu vynaložené náklady Kupujícím zpětně proplaceny. Požadavek na odstranění vad Kupující uplatní u Prodávajícího bez zbytečného odkladu po jejich zjištění. Za řádně uplatněnou reklamaci se považuje též, bylo-li oznámení o zjištěné vadě zasláno Prodávajícímu poslední den záruční doby.
- 5.4. Odstranění vady nemá vliv na případný nárok Kupujícího na smluvní pokutu sjednanou v této Smlouvě a náhradu škody, pokud mu výskytem vady vznikla. Veškeré náklady na odstranění vady nese Prodávající.
- 5.5. V případě neshody o tom, zda jde o vadu, za jejíž odstranění nese Prodávající odpovědnost, nese náklady na odstranění takové vady Prodávající, a to až do okamžiku, kdy bude o právní povaze vady pravomocně rozhodnuto.
- 5.6. Prodávající poskytuje Kupujícímu záruční dobu (záruku) pro zástavbu a přístroje v délce **60 měsíců** od převzetí předmětu koupě.
- 5.7. Prodávající poskytuje Kupujícímu záruční dobu (záruku) na vozidlo v délce **60 měsíců** od převzetí předmětu koupě. V případě nájezdu vozidla přesahujícím 150 000 km záruční doba zaniká.
- 5.8. Záruční doba počíná běžet ode dne převzetí předmětu koupě Kupujícím dle předávacího protokolu. Záruční doba se prodlužuje o dobu, po kterou bude trvat odstraňování vad. V případě odstraňování vady přístroje je Prodávající povinen po tuto dobu zajistit Kupujícímu bezúplatně náhradní přístroj v odpovídající kvalitě a podobných parametřích. Prodávající, tj. od oznámení vady do převzetí odstraněné vady předmětu koupě Kupujícím. V případě odstranění vady dodáním nové věci bez vad nebo dodáním chybějící věci začíná běžet nová záruční doba. Nic v záručním listu nesmí omezovat rozsah a délku trvání záruční doby, jakož i odpovědnost Prodávajícího vyplývající z poskytnuté záruky.
- 5.9. Prodávající dále poskytuje Kupujícímu garanci dostupnosti pozáručního servisu a náhradních dílů pro zástavbu a přístroje v délce **120 měsíců**.

## VI. Sankční podmínky

- 6.1. V případě prodlení se lhůtou plnění dle čl. 3.1. této Smlouvy, je Kupující oprávněn požadovat po Prodávajícím uhrazení smluvní pokuty ve výši 0,5 % z kupní ceny uvedené v čl. 2.1. Smlouvy, a to za každý započatý den prodlení.
- 6.2. V případě prodlení Prodávajícího s odstraněním vady ve lhůtě stanovené dle čl. 5.3. této Smlouvy je Kupující oprávněn požadovat po Prodávajícím smluvní pokutu ve výši 3.000,- CZK za každý byt' započatý den prodlení.
- 6.3. Kupující je oprávněn započíst závazek Prodávajícího vzniklý z porušení této Smlouvy oproti vlastním nesplaceným závazkům vůči Prodávajícímu.
- 6.4. Smluvní pokuty lze uplatnit kumulativně. Ujednáním o smluvní pokutě či jejím zaplacením není dotčeno právo Kupujícího na náhradu škody. Zaplacení smluvní pokuty nezavazuje Prodávajícího povinnosti splnit smlouvenou povinnost smluvní pokutou utvrzenou.

## VII. Ukončení smlouvy

- 7.1. V případě podstatného porušení smluvních povinností jednou Smluvní stranou, je druhá Smluvní strana oprávněna od této Smlouvy odstoupit.



- 7.2. Za podstatné porušení této Smlouvy se považuje zejména skutečnost, že Prodávající nedodá předmět koupě podle čl. 3.1. této Smlouvy, tj. do 30. 11. 2026.
- 7.3. Za podstatné porušení této Smlouvy ze strany prodávajícího se považuje dále:
- a) předmět koupě vykazuje vadu, která je neopravitelná,
  - b) kupující nemůže pro opětovné vyskytnutí vady po opravě či pro větší počet vad předmět koupě řádně užívat, přičemž pro vyloučení pochybností se pro účely smlouvy považuje za opětovné vyskytnutí vady po opravě, kdy dvakrát opravovaná vada se objeví potřetí, a za větší počet vad, pro který není možné předmět koupě řádně užívat, se považuje, když má předmět koupě současně tři a více vad,
  - c) neodstranění vady předmětu koupě prodávajícím ani v přiměřené lhůtě dodatečně stanovené kupujícím v písemné výzvě,
  - d) prohlášení úpadku na prodávajícího, nebo jeho vstup do likvidace.
- 7.4. Za podstatné porušení této Smlouvy ze strany Kupujícího se považuje zejména neuhrazení kupní ceny či její části ve lhůtě sjednané v této Smlouvě, a to za předpokladu, že Kupující toto porušení své povinnosti nenapraví ani do 30 dnů ode dne doručení písemné výzvy Prodávajícího k nápravě.
- 7.5. Účinnost odstoupení nastává doručením oznámení o odstoupení druhé Smluvní straně, nebo v případě zaslání oznámení prostřednictvím datové zprávy se doručením rozumí dodání datové zprávy do datové schránky Prodávajícího. Odstoupením od Smlouvy pro její podstatné porušení nezaniká povinnost příslušné Smluvní strany zaplatit druhé Smluvní straně smluvní pokuty a nahradit případně vzniklou škodu.
- 7.6. Kupující je dále oprávněn smlouvu vypovědět a odstoupit od ní v případech stanovených zákonem č. 134/2016 Sb., zákon o zadávání veřejných zakázek, ve znění pozdějších předpisů (dále jen „ZZVZ“).

### **VIII. Ostatní podmínky**

- 8.1. Smluvní strany vynaloží veškeré úsilí, aby všechny spory, které případně vyplynou z této Smlouvy nebo v souvislosti s ní, byly urovnány především vzájemnou dohodou.
- 8.2. V případě, že se dohody nepodaří dosáhnout, sjednávají Smluvní strany, že všechny spory vznikající z této Smlouvy a v souvislosti s ní budou rozhodovány s konečnou platností obecnými soudy určenými podle sídla Kupujícího.
- 8.3. Bude-li jakékoliv ustanovení této Smlouvy shledáno příslušným soudem nebo jiným orgánem neplatným, neúčinným nebo nevymahatelným, bude takové ustanovení považováno za vypuštěné z této Smlouvy a ostatní ustanovení této Smlouvy budou nadále trvat, pokud z povahy takového ustanovení nebo z jeho obsahu anebo z okolností, za nichž bylo uzavřeno, nevyplývá, že je nelze oddělit od ostatního obsahu této Smlouvy. Smluvní strany v takovém případě bez zbytečného odkladu uzavřou takové dodatky k této Smlouvě, které umožní dosažení výsledku stejného, a pokud to není možné, pak co nejbližšího tomu, jakého mělo být dosaženo neplatným, neúčinným či nevymahatelným ustanovením.
- 8.4. Prodávající je podle ustanovení § 2 písm. e) zákona č. 320/2001 Sb., o finanční kontrole ve veřejné správě a o změně některých zákonů (zákon o finanční kontrole), ve znění pozdějších předpisů, osobou povinnou spolupůsobit při výkonu finanční kontroly.
- 8.5. Prodávající je povinen po dobu 10 let od skončení plnění dle této Smlouvy uchovávat doklady související s plněním dle této Smlouvy a umožnit osobám oprávněným k výkonu kontroly projektu, z něhož je zakázka hrazena, provést kontrolu těchto dokladů.
- 8.6. Smluvní strany nejsou oprávněny postoupit jakoukoli pohledávku, která jim vznikne na základě této Smlouvy bez předchozího písemného souhlasu druhé Smluvní strany. Toto ustanovení se nevztahuje na případné právní nástupce Smluvních stran.
- 8.7. Prodávající na sebe přebírá nebezpečí změny okolností dle ustanovení § 1765 odst. 2. občanského



zákoníku.

8.8. Kontaktními osobami ve věcech technických pro účely této Smlouvy jsou:

za Kupujícího:

a) Ing. Lubomír Gryc, tel.:

za Prodávajícího:

b) Ing. Lukáš Skála, tel.:

c) Nikola Sobotková, tel.:

Smluvní strany si tímto výslovně sjednávají, že ke změně kontaktních osob ve věcech technických není potřeba uzavírat dodatek ke Smlouvě dle čl. 9.6 Smlouvy. V případě změny oznámí písemně jedna Smluvní strana druhé Smluvní straně tuto změnu a uvede nové kontaktní osoby.

8.9. Má-li být část díla realizována prostřednictvím poddodavatele, který za Prodávajícího prokázal určitou část způsobilosti, musí se poddodavatel podílet na plnění díla v tom rozsahu, v jakém se k tomu zavázal ve smlouvě s Prodávajícím a v jakém prokázal způsobilost. Prodávající je oprávněn změnit poddodavatele, pomocí kterého prokazoval v zadávacím řízení splnění způsobilosti, jen ve výjimečných případech a se souhlasem Kupujícího. Nový poddodavatel musí splňovat způsobilost minimálně v rozsahu, v jakém byla prokázána původním poddodavatelem v zadávacím řízení.



## IX. Závěrečná ujednání

- 9.1. Součástí této Smlouvy je Příloha č. 1 – Technická specifikace.
- 9.2. Tato Smlouva nabývá platnosti dne, kdy ji oprávnění zástupci obou Smluvních stran opatří svými kvalifikovanými elektronickými podpisy a účinnosti dnem jejího uveřejnění v registru smluv. Případná plnění Smluvních stran v rámci předmětu této Smlouvy před nabytím její účinnosti se považují za plnění dle této Smlouvy, včetně práv a povinností z toho vyplývajících.
- 9.3. Prodávající bere na vědomí, že tato Smlouva bude v souladu s příslušnými právními předpisy zveřejněna na profilu zadavatele a v registru smluv dle zák. č. 340/2015 Sb., o zvláštních podmínkách účinnosti některých smluv, uveřejňování těchto smluv a o registru smluv (zákon o registru smluv), ve znění pozdějších předpisů, způsobem umožňujícím dálkový přístup, s čímž vyslovuje svůj souhlas. Prodávající podpisem této Smlouvy výslovně uvádí, že žádná část této Smlouvy není vyňata z povinnosti uveřejnění zejména s ohledem na obchodní tajemství.
- 9.4. Smluvní strany shodně prohlašují, že osobní údaje uvedené ve smlouvě, případně získané v souvislosti s plněním smlouvy, použijí pouze za účelem plnění smlouvy a v souladu se zákonem č. 110/2019 Sb., o zpracování osobních údajů, v platném znění, a s nařízením Evropského parlamentu a Rady (EU) 2016/679, o ochraně fyzických osob v souvislosti se zpracováním osobních údajů a o volném pohybu těchto údajů a o zrušení směrnice 95/46/ES (obecné nařízení o ochraně osobních údajů).
- 9.5. Tato Smlouva a veškeré dodatky k ní se řídí právním řádem České republiky, zejména pak občanským zákoníkem a ZZVZ.
- 9.6. Tuto Smlouvu lze měnit pouze na základě písemných, vzestupně číslovaných dodatků podepsaných oběma Smluvními stranami.
- 9.7. Smluvní strany prohlašují, že tuto Smlouvu uzavřely na základě své pravé a svobodné vůle, že při jejím uzavírání nejednali v tísní či za nevýhodných podmínek, Smlouvu si řádně přečetly a s jejím obsahem plně souhlasí, což stvrzují svými podpisy.

za Prodávajícího dne:  
3.6.2026

za Kupujícího dne:  
3.6.2026

**Martin Pazúr**  
Předseda představenstva

**Mgr. Aleš Froňka, Ph.D.**  
ředitel



# Dodávka monitorovacího vozu II

## Technická specifikace

**Vaše značka:**

**Naše značka:** RE2494\_v02

**Vyřizuje:** SOBOTKOVÁ Nikola

**Datum:** 27. dubna 2026

**Platnost nabídky:** 60 dní

Tento dokument a veškeré informace v něm obsažené jsou majetkem společnosti NUVIA, jsou považovány za chráněné a nesmí být reprodukovány ani kopírovány, ať už jako celek nebo po částech. Tento dokument nesmí být poskytnut jiným osobám bez výslovného písemného souhlasu společnosti NUVIA a nesmí být použit žádným způsobem, který je nebo by mohl být pro společnost NUVIA škodlivý. Tento dokument a všechny jeho případné kopie musí být na požádání vráceny společnosti NUVIA.

### 1 OBSAH

1	OBSAH .....	2
---	-------------	---

2	ZÁKLADNÍ ÚDAJE O SPOLEČNOSTI.....	3
2.1	NUVIA a.s.....	3
2.2	Kontaktní osoby ve věci předložené nabídky.....	4
3	NABÍDKA.....	4
3.1	Technická nabídka .....	4
3.1.1	Technická specifikace vozu .....	4
3.1.2	Technická specifikace zástavby .....	5
3.1.3	Detekční spektrometrická trasa s HPGe .....	7
3.1.4	Vestavný systém pro směrové měření .....	8
3.1.5	Multifunkční ruční detektor dávkových příkonů a povrchové kontaminace .....	10
3.1.6	Přenosná jednofázová elektrocentrála .....	11
3.1.7	Samotná soustava s Dewarovou nádobou na tekutý dusík .....	11
3.1.8	Stojan na in situ spektrometrii uzpůsobený pro HPGe detektor uvedený výše .....	12
3.1.9	Backpack .....	12

NUVIA a.s.  
Hrotovická-Průmyslová zóna 168, 674 01 Střítež, Česká republika  
E-mail: instruments@nuviatech.com, info.cz@nuvia.com

## 2 ZÁKLADNÍ ÚDAJE O SPOLEČNOSTI

### 2.1 NUVIA a.s.

Obchodní jméno	NUVIA a.s.
Právní forma	akciová společnost
Sídlo	Hrotovická-Průmyslová zóna 168, 674 01 Střítež, Česká republika 5.11.1997
Datum vzniku	Zápis do OR KS Brno, oddíl B, vložka 2461
Dokument o vzniku společnosti	25506331
IČ	CZ25506331
DIČ	KB, pobočka Třebíč, č. účtu 6618440267/0100
Bankovní spojení	50.000.000,- Kč
Základní kapitál	info.cz@nuvia.com
E-mail	www.nuvia.com
WWW stránka	

NUVIA a.s.  
Hrotovická-Průmyslová zóna 168, 674 01 Střítež, Česká republika  
E-mail: instruments@nuviatech.com, info.cz@nuvia.com

**Supporting your energy**  
www.nuviatech-instruments.com, www.nuvia.com

## 2.2 Kontaktní osoby ve věci předložené nabídky

Jméno	Funkce	Telefon	e-mail
Lukáš SKÁLA	Hlavní inženýr	+420	
Nikola SOBOTKOVÁ	Manažer rozvoje obchodu	+420	

## 3 NABÍDKA

### 3.1 Technická nabídka

#### 3.1.1 Technická specifikace vozu

V rámci naší nabídky jsme zvolili model **Volkswagen Crafter skříň 35130 kW 8AU 4MOT SR**, protože svými parametry a konstrukčním provedením nejlépe odpovídá všem požadavkům technické specifikace zadavatele.

Požadavek – vozidlo	Splňuje	Poznámka
Emisní norma minimálně EURO 6	ANO	
Elektronické bezpečnostní systémy: ABS, ESP, protiprokluzový systém, asistent jízdy v pruhu, asistent rozjezdu, automatické nouzové brzdění, adaptivní tempomat, boční a hlavové airbagy, LED denní svícení	ANO	
Výbava: parkovací senzory vpředu/vzadu, zadní kamera, infotainment (CarPlay/Android Auto), DAB, multifunkční volant, bezdrátové nabíjení, klimatizace, el. okna/zrcátka, vyhřívání skel a sedadel, přepážka, 2 sady kol, rezervní kolo, loketní opěrka, centrální zamykání, madla, odkládací prostor	ANO	
Počet míst k sezení: 3	ANO	
Celkový počet dveří 4 (přední 2, pravé boční posuvné s tónovacím oknem, zadní dvoukřídlé 270° s tónovacími okny)	ANO	
Barva karoserie: modrá	ANO	
Rozměry: délka 5250–6000 mm	ANO	
Rozměry: výška 2500–2650 mm	ANO	
Rozměry: šířka 2000–2100 mm (bez zrcátek)	ANO	
Typ hnacího stroje: naftový motor	ANO	
Jmenovitý výkon motoru min. 120 kW	ANO	
Počet válců min. 4	ANO	
Zdvihový objem min. 2,0 l	ANO	
Automatická převodovka s pohonem všech čtyř kol – 4x4	ANO	
Palivová nádrž min. 70 l	ANO	

NUVIA a.s.  
Hrotovická-Průmyslová zóna 168, 674 01 Střítež, Česká republika  
E-mail: instruments@nuviatech.com, info.cz@nuvia.com

Tabulka 1 - Seznam požadavků pro vozidlo



Obrázek 1 - Ilustrativní obrázek Volkswagen Crafter

## 3.1.2 Technická specifikace zástavby

Požadavek – zástavba	Splňuje	Poznámka
Hmotnost automobilu včetně zástavby max. 3300 kg	ANO	
Zástavba rozdělena na laboratorní část a část pro příslušenství	ANO	
Přístup: boční posuvné skleněné dveře + zadní dvoukřídlé dveře	ANO	
Laboratorní část oddělena pevnou kovovou přepážkou	ANO	
Posuvné okno v přepážce min. 40 × 30 cm	ANO	
Konstrukce umožňuje převoz OOPP, odběrového a dekontaminačního vybavení	ANO	
<ul style="list-style-type: none"> <li>• Roletkové prvky se zábranou proti vnikání předmětů při chodu roletky</li> <li>• Skříňky/šuplíky s blokadí proti otevření při jízdě (bez nutnosti zamykat)</li> <li>• Úložný systém ze slitiny lehkých kovů</li> <li>• Stahovací pásy odolné pro opakované použití</li> <li>• Zápustné upínací lišty na podlaze + upínací oka</li> <li>• Upínací lišty na stěnách + odnímatelná oka</li> <li>• Sklopná kotevní podlahová oka</li> </ul>	ANO	

NUVIA a.s.  
Hrotovická-Průmyslová zóna 168, 674 01 Střítež, Česká republika  
E-mail: instruments@nuviatech.com, info.cz@nuvia.com

**Supporting your energy**

www.nuviatech-instruments.com, www.nuvia.com

Podlaha v protiskluzovém a antistatickém provedení	ANO
Demontovatelná skříňková zástavba s pracovní deskou (výška 750 mm)	ANO
Vestavěné šuplíky pod pracovní deskou	ANO
Druhá strana: skříňová zástavba do stropu	ANO
Upínací lišty po bocích zástavby	ANO
Materiál nábytku snadno omyvatelný	ANO
Všechny hrany desek jsou zaoblené	ANO
Pevná držadla u zadního i bočního vstupu	ANO
Stropní LED osvětlení s ovládáním u obou vstupů	ANO
Drátěný systém pro uchycení kanystru na zadních dveřích	ANO
Stínící box přizpůsobený HPGe detektoru:	ANO
• Materiály stínění: olovo, nerezová ocel, měď	ANO
• Konstrukce vertikální nebo horizontální	ANO
• Útlum: poměr impulzů 137Cs min. 200	ANO
Stahovací markýza min. 80 % délky nástavby	ANO
Výsuv markýzy min. 2 m	ANO
Markýza nepřesahuje výšku vozidla o více než 100 mm	ANO
Markýza má ochranné prvky vpředu i vzadu	ANO
Bezpečnostní zámky markýzy proti otevření za jízdy	ANO
Nezávislý vnitřní elektrický okruh	ANO
Externí baterie min. 140 Ah fixně ukotvena	ANO
Nabíječka baterie v zadní části zástavby	ANO
Baterie pro napájení přístrojového vybavení	ANO
Měnič DC → AC 230 V	ANO
Výstup měniče min. 560 W	ANO
Typ signálu: čistý sinus	ANO
Výstup měniče: 2× síťová zásuvka	ANO
Vnější zásuvka 230 V AC	ANO
Vnější dobíjecí zásuvka 230 V AC	ANO
Vnější zásuvka 12 V DC (napojena na externí baterii)	ANO
Při síťovém připojení současně běží přístroje + dobíjení baterie	ANO
Výstražná oranžová LED světla: 2× vpředu, 2× vzadu	ANO
Ovládání výstražných světel z kabiny řidiče	ANO
Výbava ADR zahrnutá:	ANO
• Hasicí přístroj min. 2 kg v kabině	ANO
• Hasicí přístroj min. 6 kg v nákladovém prostoru	ANO
• Oranžové sklopné ADR tabule vpředu	ANO
• Oranžové sklopné ADR tabule vzadu	ANO

Tabulka 2 - Seznam požadavků pro zástavbu

## 3.1.3 Detekční spektrometrická trasa s HPGe

Koaxiální HPGe detektor ORTEC GEM25P4-SMP-76 (POP TOP, SMART rozhraní, HE option – zodolněný), dewarova nádoba 7 litrů Gamma Gage II Portable Cryostat/Dewar.

Požadavek – spektrometrická trasa	Splňuje	Poznámka
Mobilní zodolněný HPGe detektor do terénu s předzesilovačem ve společném kryostatu	ANO	Model GEM25P4-SMP-76
Měření ve vestavěném stínění i na in situ spektrometrii	ANO	
Min. účinnost detektoru 25 % vůči 3"×3" NaI(Tl) na energii 1332 keV v 25 cm	ANO	25 %
Koaxiální krystal: délka = průměr (tolerance ±4 mm)	ANO	
Energetický rozsah 40 keV – 3 MeV	ANO	
Energetické rozlišení FWHM na 1,33 MeV (Co-60) max. 1,9 keV	ANO	1,85 keV
Energetické rozlišení FWHM na 0,122 MeV (Co-57) max. 0,9 keV	ANO	0,82 keV
Chlazení zkapalněným dusíkem	ANO	
Dewarova nádoba 5–7 litrů součástí systému	ANO	7 litrů
Provozní orientace horizontální i vertikální	ANO	
Madlo pro přenos systému v terénu	ANO	
Kompatibilita s MCA Ortec digiDart	ANO	
Technická dokumentace pro Monte Carlo modelování	ANO	
Software pro zpracování a export spekter	ANO	GamWin + ORTEC Maestro
Zodolněný NTB s Win11 nebo vyšší + MS Office	ANO	
Kompaktní terénní MCA kompatibilní s HPGe	ANO	
MCA počet kanálů min. 16k	ANO	16k kanálů
MCA: vestavěný podsvícený LCD displej	ANO	
MCA: ukládání spekter s možností zpětného zobrazení	ANO	
Nastavení parametrů detektoru přímo na analyzátoru	ANO	
Displej MCA zobrazuje stav a parametry detektoru	ANO	
Možnost nastavení parametrů přes PC/NTB	ANO	(přes GAMWIN nebo MAESTRO)
Napájení MCA akumulátorem, výdrž min. 8 h	ANO	9 hod.
Odolnost MCA min. IP54	ANO	IP54
Propustnost MCA min. 100 000 impulsů/s	ANO	
Interní paměť + export ve formátech. cnf, .chn, .spe, .GSPC	ANO	
Konektivita – min. USB 2.0	ANO	

NUVIA a.s.  
Hrotovická-Průmyslová zóna 168, 674 01 Střítež, Česká republika  
E-mail: instruments@nuviatech.com, info.cz@nuvia.com

**Supporting your energy**  
www.nuviatech-instruments.com, www.nuvia.com

Hmotnost MCA max. 2 kg

ANO

&lt;1,2 kg (včetně akumulátoru)

Tabulka 3 - Seznam požadavků pro spektrometrickou trasu



Obrázek 2 – HPGe detektor



Obrázek 3 – digi DART

### 3.1.4 Vestavný systém pro směrové měření

Vestavný systém pro směrové měření je tvořen kombinací několika typů detektorů a řídicích prvků, které umožňují spolehlivou detekci a lokalizaci zdrojů ionizujícího záření během jízdy i při stacionárním měření. Systém zahrnuje GM trubici s širokým měřicím rozsahem, dva scintilační detektory NaI(Tl) o objemu 1 dm<sup>3</sup> a 348 cm<sup>3</sup> umístěné v nákladovém prostoru a dvojici směrových plastových detektorů o objemu 1,5 dm<sup>3</sup>. Integrovaný GNSS přijímač zajišťuje průběžné zaznamenávání polohy.

Požadavek	Splňuje	Poznámka
GM trubice – měřicí rozsah 50 nGy/h–20 mGy/h pro energie 40 keV – 3 MeV	ANO	NuDET EGM-01.G2
Dva scintilační detektory NaI(Tl) o objemu 1 dm <sup>3</sup> a 348 cm <sup>3</sup> (3" x 3")	ANO	NuDET ENA
2 směrové plastové detektory, objem 1,5 dm <sup>3</sup> / detektor	ANO	

NUVIA a.s.  
Hrotovická-Průmyslová zóna 168, 674 01 Střítež, Česká republika  
E-mail: instruments@nuviatech.com, info.cz@nuvia.com

**Supporting your energy**

www.nuviatech-instruments.com, www.nuvia.com

GNSS přijímač	ANO
Napájení systému: externí 12 V	ANO
Zodolněný notebook s OS Win 11 nebo vyšším + MS Office	ANO
Ovládací a zobrazovací software	ANO
Ovládání celého systému přes notebook	ANO
Možnost připojení více notebooků pro sledování měřených dat	ANO
System umožňuje nezávislý chod bez trvalé přítomnosti notebooku	ANO
SW zobrazuje: měřená spektra, waterfall, dozimetrické veličiny, GNSS souřadnice, datum	ANO
SW není závislý na HW či SW klíči (bez donglu)	ANO
Automatické ukládání dat vč. polohy, data a času	ANO
Technické prostředky pro online přenos dat	ANO
Vzorkovací čas pevně 1 s	ANO
SW umožňuje plovoucí integrační okno pro analýzu spektra	ANO
Export dat kompatibilní s MonRaS (SÚJB)	ANO
Export dat do CSV	ANO

Tabulka 4 - Seznam požadavků pro vestavný systém a směrové měření



Obrázek 4 – Odolný notebook

NUVIA a.s.  
Hrotovická-Průmyslová zóna 168, 674 01 Střítež, Česká republika  
E-mail: instruments@nuviatech.com, info.cz@nuvia.com

**Supporting your energy**  
www.nuviatech-instruments.com, www.nuvia.com



Obrázek 5 – NuDET EGM, NuDET ENA 3“

### 3.1.5 Multifunkční ruční detektor dávkových příkonů a povrchové kontaminace

Multifunkční ruční detektor RadEye B20 představuje kompaktní a lehký přístroj určený pro měření povrchové kontaminace alfa, beta a gama zářením a pro orientační měření dávkových příkonů.

Požadavek	Splňuje	Poznámka
Měření povrchové kontaminace alfa, beta, gamma v cps, Bq/cm <sup>2</sup>	ANO	RadEye B20
Rozsah dávkových příkonů H*(10) do 2 mSv/h (do 3 MeV)	ANO	0–2 mSv/h s gama filtrem
Napájení: uživatelsky vyměnitelné komerční baterie	ANO	2× AAA, provozní doba přes 500 hodin
Indikace alarmů: světelná, zvuková, vibrační	ANO	Kombinovaná LED, zvuková a vibrační signalizace
Hmotnost do 400 g	ANO	
Opaskové pouzdro	ANO	Součást dostupného příslušenství
Pouzdro s popruhem přes rameno	ANO	Součást dostupného příslušenství

Tabulka 5 - Seznam požadavků pro multifunkční ruční detektor



Obrázek 6 – RadEye B20

NUVIA a.s.  
Hrotopická-Průmyslová zóna 168, 674 01 Střítež, Česká republika  
E-mail: instruments@nuviatech.com, info.cz@nuvia.com

## 3.1.6 Přenosná jednofázová elektrocentrála

Požadavek	ANO	Poznámka
Hmotnost max. 25 kg	ANO	Honda EU 22i
Minimální jmenovitý výkon 1800 VA	ANO	
Maximální jmenovitý výkon 2500 VA	ANO	
Minimální jmenovitý proud 7 A	ANO	
Napětí / frekvence 230 V / 50 Hz	ANO	
Palivo: benzín	ANO	
Objem palivové nádrže min. 3 l	ANO	
Startování: ruční	ANO	
Stupeň krytí IP23	ANO	
Zásuvky 230 V: 2× Schuko (16 A / 230 V)	ANO	
Stejnoseměrný výstup 12 V / min. 7 A	ANO	
Typ motoru: čtyřtákní	ANO	

Tabulka 6 - Seznam požadavků pro elektrocentrálu



Obrázek 7 – Elektrocentrála

## 3.1.7 Samotná soustava s Dewarovou nádobou na tekutý dusík

Požadavek	Splňuje	Poznámka
Dewarova nádoba o objemu 10 litrů	ANO	
Vypouštěcí zařízení	ANO	
Plnicí jehla	ANO	PFB-MOD7L – tlakové plnicí adaptéry pro Dewarovy nádoby příslušných velikostí s možností vícesměrné orientace

NUVIA a.s.  
Hrotovická-Průmyslová zóna 168, 674 01 Střítež, Česká republika  
E-mail: instruments@nuviatech.com, info.cz@nuvia.com

Tabulka 7 - Seznam požadavků pro Dewarovu nádobu

## 3.1.8 Stojan na in situ spektrometrii uzpůsobený pro HPGe detektor uvedený výše

Požadavek	Splňuje	Poznámka
Maximální výška ve složeném stavu 110 cm	ANO	
Maximální výška v rozloženém stavu 180 cm	ANO	

## 3.1.9 Backpack

Přenosný "batohový" spektrometr s GPS (napájení na baterii, ukládání geotagovaných spektrometrických dat) pro pěší gamaspektrometrické mapování.

Požadavek	Splňuje	Poznámka
Dva NaI(Tl) 3 inch x 3 inch	ANO	
GNSS přijímač	ANO	
Software instalovatelný na iOS/Android	ANO	
Automatické logování dat s integračním časem 1 s	ANO	
Export dat do .csv	ANO	
Výdrž na baterii: min. 12 h	ANO	
Max hmotnost včetně batohu: 11 kg	ANO	
IP 54	ANO	



**NUVIA a.s.**

Hrotovická-Průmyslová zóna 168,674 01 Střítež, Česká republika

E-mail: [instruments@nuviatech.com](mailto:instruments@nuviatech.com), [info.cz@nuvia.com](mailto:info.cz@nuvia.com) WWW.

[nuviatech-instruments.com](http://nuviatech-instruments.com)

[www.nuvia.com](http://www.nuvia.com)



*Supporting your energy*

**OfiTEC**<sup>®</sup>

digiDART<sup>™</sup>  
Portable HPGe MCA



‘The EXTRA-ordinary portable HPGe MCA!’

**UNETEK**<sup>®</sup>  
ADVANCED MEASUREMENT TECHNOLOGY

# digiDART™

- High-performance RUGGED HPGe grade spectrometer, 16k channels.
- DIGITALLY stable: consistent answers for long counts, changing count-rates and temperatures.
- Operates WITHOUT an attached PC.
- Built-in backlit LCD display and control keypad — Live display of acquiring data.
- Energy calibration using keypad.
- Nuclide ID and activity calculation for nine Regions of Interest (ROI).
- High throughput — over 100,000 processed pulses per second.
- Fits in the palm of your hand or hangs from your belt.
- Holds 23 16k spectra in internal memory (614 at 512 resolution).
- Battery life >9 hours.
- Only 860 grams, including batteries.
- Fast USB communications.
- Supports the latest generation "SMART-1" HPGe detectors and all other detectors using the DIM.
- Provides Authentication of spectral data.
- Optional 32k channel resolution model.

The ORTEC DigiDART is an extraordinary, portable, HPGe-grade Multichannel Analyzer. It has been carefully engineered to perform the most demanding real world, PORTABLE gamma-ray spectroscopy applications. The entire design, from the on-board display to the package ergonomics, answers the needs of people like you — leading practitioners of in-field spectroscopy.

As you expect from ORTEC, the DigiDART is an advanced, *all-digital design*, with three ORTEC-held patents<sup>1</sup> — clearly advancing the state of the art for portable MCAs.

## digiDART . . . Tough, yet light.

Weighing less than 1160 grams, the DigiDART is an attractive, light-weight instrument; easy to handle, and RUGGED. The case is molded ABS — the same strong plastic used extensively in automobiles. The outside is coated with a shock-absorbing, easy-grip, stay-clean coating — just like your other tools. The display and keypad are recessed to protect them when the instrument is dropped. The connectors are all on one side and recessed for protection. The battery is inside — again for added protection and covered with a splash-proof door. It can be charged in place, even when the DigiDART is operating. The battery is truly integrated into the rugged DigiDART and not simply clipped on the back panel; exposed and easy to break. Changing the battery is simple: just open the door and replace.

### DigiDART Display and Keypad

Naturally, the DigiDART is entirely computer controllable; but with the built-in display and numeric keypad, it is a DRAMATIC ADVANCE from the current generation of portable MCAs. This high-quality display and easy to use keypad mean it can perform a variety of tasks without an attached PC.

For in-field applications, a PC is difficult to carry and operate, but without a display you can't see the spectrum or results. The DigiDART's built-in, backlit LCD display panel and keypad provide the confidence you need that your data is good. A clear spectral display is provided and start/stop control is accomplished simply by a single keypad entry.

The spectral Display of the DigiDART is patterned after ORTEC's very successful MAESTRO MCA Emulator, in use on thousands of systems worldwide. A 240 x 160 pixel LCD display allows the user to monitor acquisitions and instrument settings status, with no attached PC. It features a live spectral display with region of interest, peak information and on line activity calculations. ROIs are shown as a bar below the spectrum.

<sup>1</sup>U.S. Patents No's. 5,821,533; 5,872,363 and 5,912,825

## Keypad and Display Features



- 1 - View Status
- 2 - Enter ID
- 3 - Nuclide ROIs
- 4 - Status Line
- 5 - Peak Info
- 6 - Adjust Controls
- 7 - General Settings
- 8 - Spectrum Memory

Live Time Real	72531
Time Dead	72730
Time (%)	0.274
Battery (% full)	100
Fine Gain	0.700
Coarse Gain	2
Rise Time Flat	10.200
Top BLR	0.800
Setting	3

Nuclide	keV	μCi	±%
241Am	59.5	1.72	5.2
109Cd	88	2.19	10.1
57Co	122	0.93	4.9
57Co	136	0.89	8.7
137Cs	661.6	2.6	2.5
60Co	1173	0.79	5.3
60Co	1332	0.81	5.1
40K	1460	0.02	11.4
208Tl	2614	0.01	21.7

## Real Time Activity Calculations . . . NO PC Required!

DigiDART can also perform nuclide ID and activity calculations using internally stored calibration information, at the touch of a button, and all without the use of an attached PC. Everything is user controlled: the library for analysis, displayed peak labels, unit labels and calibration parameters. They are all easily downloaded by MAESTRO to the DigiDART, but they can be changed in-field to adapt to your changing needs. Activity is calculated for the list of up to 9 nuclides. The spectral data can be saved and later re-analyzed in more detail using a more sophisticated PC-based analysis package such as GammaVision.

## Operator Menus

All of the DigiDART screens and operations are set using the keypad and the display. The operation is simple — select what you want from the displayed list by number and the Enter key. The main groups are: View Status, Enter ID, Nuclide ROI contents, Peak Info, Select ROIs, Select Status contents, Adjust controls, general settings and View memory contents. The complete list of all functions is given in the specification section.

Using the keypad and the display, the MCA settings can be verified or changed in the field without a host computer.

## Protection

Protection of the data is important, so the MENUS have password protection. The operations are separated into two groups: USER and ADMINISTRATOR. The USER password protects the instrument from unauthorized use. That is, you can protect your data stored in the internal memory. The ADMIN or Setup functions are protected by a different administrator password. The ADMIN functions can only be changed by the Administrator ensuring that your results are based on the correct parameters.

## SMART-1 HPGe Detector Support

ORTEC's SMART-1 detector technology is a great advance in HPGe detectors and their operation. SMART-1 technology is a major enhancement to data and chain of custody integrity. It is a dramatic improvement in detector management practice and data control.

A SMART-1 HPGe detector is intelligent. The built-in controller monitors and reports on all vital system functions. Individual vital signs are available as well as the overall "state of health." The detector controller knows who it is: each unit has its own identification serial number. To further increase data integrity, the controller can even store authentication codes and later return the code to ensure traceability of the data.

DigiDART uses the special SMART-1 "state of health" (SOH) function to verify that the detector was operating properly for the entire data collection time. When the acquisition is started, DigiDART clears the SOH register in the SMART-1 controller. During data acquisition, the SMART-1 detector monitors all of its

own "vital functions." Should any of the monitored functions fall outside a specified range of values (even if they subsequently return to normal), the condition is registered and at the end of the acquisition the DigiDART reads the SOH and displays a warning message if a problem was detected. No Message — no problem. The SOH status is saved with the spectral data in the SPC file as part of the QA process. Any CONNECTIONS program, even user-developed packages, may read the SOH register through the DigiDART for maintaining the spectrum QA.

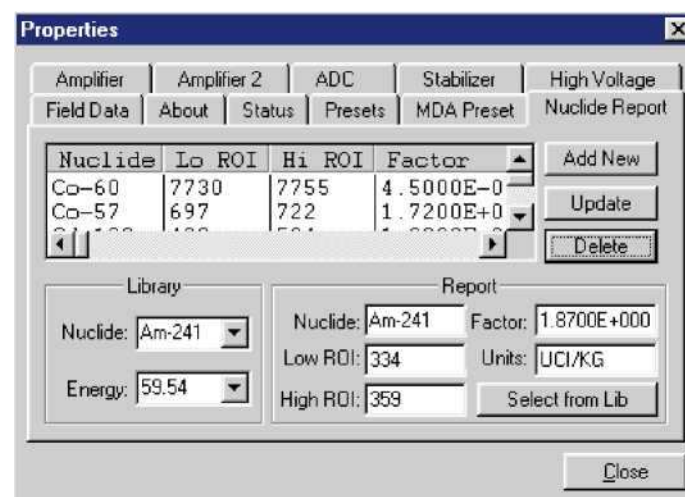

DigiDART is fully integrated with ORTEC software applications such as MAESTRO which can easily download setup parameters.

## Authentication using the SMART-1 Detector

The DigiDART/SMART-1 combination also guarantees spectrum authenticity. At the start of the acquisition, the DigiDART reads the SMART-1 detector serial number. The DigiDART generates a random number and writes it to the SMART-1 detector. At the end of the acquisition, the DigiDART reads both numbers from the SMART-1 detector and compares the "stop" values to the "start" values. An exact match assures data integrity. Because DigiDART, like all ORTEC MCA products, forms part of the *CONNECTIONS* architecture, these operations may be carried out remotely over a network, making DigiDART **IDEAL** for unattended monitoring applications. The combination of the DigiDART and a SMART-1 detector is all that is required to provide full functionality and traceability. The SMART-1 detector includes the module shown in the figure which houses the HV and the detector controller. The cables are captive, strain-relieved and sealed against water penetration, eliminating the high voltage connectors and all the problems of HV connectors.



SMART-1 Detector Interface Module.

## Detector Interface Modules for non-SMART-1 HPGc Detectors

For older, non-SMART-1 detectors a DigiDART system is completed with a Detector Interface Module (DIM). The DIM includes the HV, controlled from the DigiDART, and connects to the "usual" detector connections for preamplifier and high voltage. DIMs are available for all types of detectors used with the DigiDART. The DIM connects to the DigiDART with a single cable.

## System Specifications

**Display:** 240 x 160 pixel backlit LCD provides LIVE spectral display, status information and analysis results.

**Full Display and Zoom Modes:** Display of multiple ROIs.

**Status Line:** User-configurable parameter display. Choice of two from: cursor energy, location, live time, live time remaining, real time remaining, battery life remaining, Count rate, Count rate in ROI, counts.

The spectral display may be disabled from an attached computer using an administrator function.

**Energy Calibration:** Two point energy calibration of channel and FWHM.

**On Line Activity Calculation:** Activity and uncertainty are calculated and reported on-screen, on-line for up to 9 user-defined regions. Activity is calculated as net count-rate divided by user supplied efficiency factor.

**Presets:** Live time, real time, integral peak count, peak count, uncertainty and Multi-Nuclide MDA. Up to 20 nuclide ROIs may be specified. Acquisition halts when all MDA requirements have been satisfied. Real/Live Time in multiples of 1 sec.

**Keypad:** 20 numeric and function keys. Many of the DigiDART function keys are multi-function. The precise function depends on the context at the time the key is pushed.

When the unit is connected to a computer via the USB, the keypad is locked out.

### Menu Functions

Pressing the Menu button while a spectrum is displayed brings up the Main Menu.

### Main Menu Options

**View Status:** Displays all of the major MCA settings, including: Live time, Real time, Dead time, Battery voltage, Bias voltage, Fine gain, Coarse gain, Rise time, Flat top, Baseline restore [BLR] setting.

**Enter ID:** Entry dialog for a numerical ID included with the spectrum.

**Nuclide ROIs:** View the nuclide report and the setup menu for the Nuclide Report. The following are entered for each of the 9 ROIs:

ACTIVE/DISABLED, Label (text), Units (text), Start Channel, number of channels, area multiplier, Clear this ROI, Show these settings.

**Status Line:** Setup the Status Line at the top of the spectrum display to show any two of the following parameters: Cursor location (energy), Cursor location (channel), Live time, Real time, Live time remaining, Real time remaining, Battery time remaining, Count rate, Count rate in ROI, Counts in marker channel.

**Peak Info:** Displays the centroid, FWHM, net counts and gross counts for the region identified by the marker position. Access is denied when spectrum display is locked.

**Adjust Controls:** Displays dialog for the following:

HV Settings: View and set the following: enable HV, Set Bias Voltage, Set Shutdown mode, View Current HV value, View SOH.

Amplifier Settings: View and set the following: Coarse Gain, Fine Gain, Rise Time, Flat Top, Pole Zero, Baseline Restore, Optimize, Preamp

Type, Input Polarity.

Preset Settings: View and set the following: Live Time Preset, Real Time Preset, ROI Integral Preset, ROI Peak Preset, Uncertainty Preset, MDA Presets.

ADC Settings: Set the Conversion Gain, LLD, ULD, and gate.

Stabilization Settings: Enable, view and setup the Gain and Zero stabilizers.

### General Settings

Change User Password

Change Admin Password

Enter Password

Lock Spectral Display

Auto-Contrast: Enable or Disable

Calibrate: Enter or view the Calibration

Display

Adjust vertical scale to Auto, Log, or Normal

Set Mode to PHA

View Settings

**Spectrum Memory:** Retrieve, list or erase stored spectra.

### MCA Specifications

Maximum system throughput >100,000 cps

#### System Gain Settings:

Coarse Gain: 1, 2, 4, 8, 16, or 32

Fine Gain: 0.45 to 1

With the available range of gain settings, the system is suitable for all types of HPGe detectors. Specifically the following FULL SCALE energy ranges are achievable (assuming standard ORTEC preamplifier):

COAX 187 keV to 12 MeV

LO-AX 94 keV to 6 MeV

GLP/SLP 16.5 keV to 1 MeV

Iglet-X 8 keV to 500 keV

**Preamplifiers:** Select either resistive or TRP preamplifier.

**System Conversion Gain:** The system conversion gain is software controlled from 512 to 16k channels in the standard model and 512 to 32k channels in the optional -32 model.

#### Digital Filter Shaping-Time Constants

Rise times: 0.8  $\mu$ s to 20  $\mu$ s in steps of 0.2  $\mu$ s.

Flat tops: 0.5 to 2.0 in steps of 0.1  $\mu$ s

**Dead-Time Correction:** Extended live-time correction according to Gedcke-Hale method. Accuracy: Area of reference peak changes  $\pm$ 3% from 0 to 50,000 counts per second.

#### Linearity

Integral Nonlinearity:  $\leq$   $\pm$ 0.025% over top 99.5% of spectrum, measured with a mixed source (55Fe @ 5.9 keV to 88Y @ 1836 keV).

Differential Nonlinearity:  $\leq$   $\pm$ 1% (measured with a BNC pulser and ramp generator).

Digital Spectrum Stabilizer: Controlled via computer, stabilizes gain and zero errors.

#### System Temperature Coefficient

Gain: <35 ppm/°C. [Typically 30 ppm/°C.]

Offset: <3 ppm/°C, with Rise and Fall times of 12 μs, and Flat Top of 1 μs. (Similar to analog 6 μs shaping.)

**Pulse Pile-Up Rejector:** Automatically set threshold. Pulse-pair resolution typically 500 ns.

**Automatic Digital Pole-Zero Adjustment:** Computer controlled (U.S. Patent No. 5,872,363). Can be set automatically or manually. Remote Diagnostics via Insight Oscilloscope mode.

**Digital Gated Baseline Restorer:** Computer controlled adjustment of the restorer rate (High, Low and Auto).

**LLD:** Digital lower level discriminator set in channels. Hard cutoff of data in channels below the LLD setting.

**ULD:** Digital upper level discriminator set in channels. Hard cutoff of data in channels above the ULD setting.

**Ratemeter:** Count-rate display on MCA and/or PC screen.

**Battery:** A single battery is inserted through door in case. The compartment is semi-sealed and designed to resist dirt and moisture. The battery may be changed without loss of data or charged in the field with no tools.

Battery Life: Up to 14 hours with fully charged Sony NP-F970 and standard ORTEC resistive feedback preamplifier.

Battery Type: Lithium-ion Camcorder Battery. Sony NP-F970 (7.2 V 47.5 W hr).

## Inputs and Outputs

**Detector:** Multipin connector with the following:

Preamp Power: 1 W max. (+12 V, -12 V, +24 V, -24 V, 2 GND)

Amp In: Normal amplifier input.

TRP Inhibit

Battery Power: (5–12 V) for HV module.

Control for HV and SMART-1 Detector: (2 wires).

**USB:** Universal serial bus for PC communications.

**Power:** Connection to supply power from a wall mounted dc supply. (+12 V DC <1.25 A) (Charging circuitry and battery management circuitry internal to DigiDART).

## Electrical and Mechanical

**Dimensions:** DigiDART 8" x 5" x 3" (20.32 x 12.7 x 7.62 cm)  
DIM 4.4" x 1.25" x 2.6 (W) [3" with handle]

**Weights:** DigiDART 1150 gm with battery (2.5 lb)  
850 gm without battery (1.9 lb)  
DIM <240 gm (0.5 lb)

**Operating Temperature Range:** -10 to 60°C, including LCD Display.

## Detector High Voltage Supplies

DigiDART offers high voltage supply flexibility in the form of a microprocessor controlled module, which connects the specific detector to the MCA. On a SMART-1 HPGe detector, the HV module is integral with the detector itself. For "legacy" or "non-SMART" detectors, the HV supply is in the form of a Detector Interface Module or "DIM" with 6" cables, each

with a mating connector for the traditional detector cable set:

9-pin D preamp power cable

Analog In

Shutdown In Bias Out Inhibit In

DIMs are available with the following high voltage options:

**DIM-POSGE** Detector Interface Module for ANY Non-SMART-1 positive bias HPGe detector.

**DIM-NEGGE** Detector Interface Module for ANY Non-SMART-1 negative bias HPGe detector.

**DIM-POSNAI** Detector Interface Module for ANY positive bias NaI detector.

In all cases, Bias Voltage Setting and Shutdown polarity are set from the computer using the DigiDART. The DigiDART can monitor the output voltage and shutdown state.

In addition, the SMART-1 detector provides additional state of health information by monitoring the following functions:

Preamplifier ±12, ±24 Volt values (read only)

Detector element temperature (read only)

Detector high voltage value (read only)

Detector high voltage state (on/off) (read/write)

Detector overload state

Detector HV shutdown state

Detector serial number (read only)

Detector authentication code (read/write)

## Ordering Information

Model	Description
DigiDART	DigiDART with MAESTRO software, 2 cables, battery and charger, operator manual, instruction card and USB Driver instruction sheet. NO DIM, for use with SMART-1 equipped detector.
DigiDART-POSGE	DigiDART with DIM-POSGE detector interface module for non-SMART positive bias HPGe detector
DigiDART-NEGGE	DigiDART with DIM-NEGGE detector interface module for non-SMART negative bias HPGe detector
DigiDART-POSNAI	DigiDART with DIM-POSNAI detector interface module for positive bias NaI detector
DigiDART-R-POSNAI	DigiDART with DIM-POSNAI detector interface module for positive bias NaI detector with RS-232-C communications
DigiDART-296	DigiDART with DIM-296 detector interface module for NaI detector
DigiDART-32	32k channel DigiDART with MAESTRO Software, NO DIM, for use with SMART-1 equipped detector.
DigiDART-32-POSGE	DigiDART-32 with DIM-POSGE detector interface module for non-SMART positive bias HPGe detector
DigiDART-32-296	DigiDART-32 with DIM-296 detector interface module for NaI detector
DigiDART-OPT1	Spare high capacity battery
DigiDART-OPT2	Battery charger 110–240 V 50/60 Hz
DigiDART-OPT2-E	Battery charger 110–240 V 50/60 Hz, CE approved for Europe
DigiDART-OPT3	Field Kit: carry strap/belt strap, auto adapter, universal mains adapter; spare battery
DigiDART-OPT4	RS-232 communication option (contact factory)

### Additional DIMS:

DIM-POSGE	Detector Interface Module for non-SMART positive bias HPGe detector
DIM-NEGGE	Detector Interface Module for non-SMART negative bias HPGe detector
DIM-POSNAI	Detector Interface Module for positive bias NaI detector

### Example System Order:

DigiDART  
GEM10P4-70-SMP  
CFG-PG4-3

Specifies a DigiDART; 10% GEM PopTop detector with SMART-1 technology; and a 3-liter Gamma Gage portable cryostat/dewar.

### Software Prerequisites

Setup and spectrum recovery requires a suitable version of MAESTRO (supplied with DigiDART) or other ORTEC CONNECTIONS applications.

Specifications subject to change  
080818

# ORTEC

[www.ortec-online.com](http://www.ortec-online.com)

Tel. (865) 482-4411 • Fax (865) 483-0396 • [ortec.info@ametek.com](mailto:ortec.info@ametek.com)  
801 South Illinois Ave., Oak Ridge, TN 37830 U.S.A.  
For International Office Locations, Visit Our Website

# AMETEK

- Standard holding times in the range of 1–5 days<sup>1</sup>
- Available in all-attitude and compact multi-orientation dewar types
- Lightweight: <11 lbs for 24-hour holding time version
- Available for all GEM, GMX or GLP detectors
- Automatic high-voltage shutdown and high count-rate indicator
- PopTop or Streamline versions

Gamma Gage II is intended for most any situation in which it is necessary to "take the instrument to the sample." Examples of such measurements are found in many waste assay and site characterization measurements, as well as nuclear materials holdup, and portable safeguards isotopic ratio measurements. In some cases, a Gamma Gage dewar is an excellent solution when space/weight is at a premium, for example, in Whole Body Counting applications or in some multi-detector research applications, although increasingly, electrical cooling is a viable alternative in these.



The integral LN2 dewar is available in a variety of hold times to suit the measurement constraints on size/weight and holding time.

### A Tale of Two Dewars

Two dewar type options on Gamma Gage II allow a choice between complete all-attitude no-spill operation and no-spill operation in a slightly restricted range of attitudes from a more compact dewar, the MOD dewar.

The definition of an all-attitude dewar is, apart from the inevitable venting of boil-off liquid nitrogen during use, the liquid refrigerant cannot escape from the dewar while the detector is in use, regardless of the orientation ("attitude") of the dewar. This is achieved by the relatively simple expedient of making the single fill-vent tube extend to the geometrical center of the LN2 reservoir. Thus whatever the orientation of the dewar, the fill/vent tubes are above the level of the liquid. The dewar is never more than 50% full.

In some situations, the constraint on size is more important, and a dewar which may be filled completely is required, even at the expense of having to restrict the range of movement allowed without some venting of refrigerant. The MOD (multi-orientation dewar) option allows this. It may be operated pointing vertically upward, downward or horizontally. Table 1 gives the choice criteria between all-attitude and MOD dewar types; the basic tradeoff is between minimum size/weight for a given holding time and avoidance of loss of liquid refrigerant.

Table 1. Multi-Orientation Dewar vs. All-Attitude Dewar		
	MOD	All-Attitude
Ease of filling with a funnel	More difficult and slower than all-attitude	Fills Easily
Ease of filling with a pressurized source	Equal	
Storage/Fill Dewar	Not compatible	Easily used with S/F dewar
Size	Smaller (all of the volume is utilized for LN)	Larger (only half the dewar volume is utilized for LN)
Dry Weight (Same LN <sub>2</sub> Capacity)	Smaller dewar equals lighter weight	Larger dewar equals heavier weight (~4 lbs.)
Spill Possibilities	LN is Easily Spilled by moving dewar	Very Difficult to make LN spill out of ports
Rotation About Center Axis	Causes pressurization of dewar and consequent leakage of refrigerant	No LN is spilled
Rotation on Longitudinal Axis (Tilting Up or Down)	Position Fill port above Vent port to minimize LN spilling	No LN is spilled

### All-Attitude Dewar

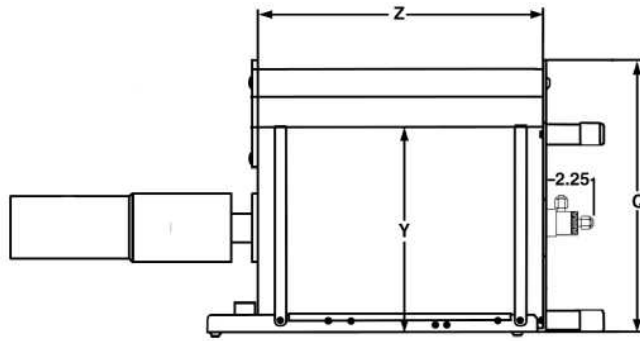

### Gamma Gage II Portable Cryostat/Dewar

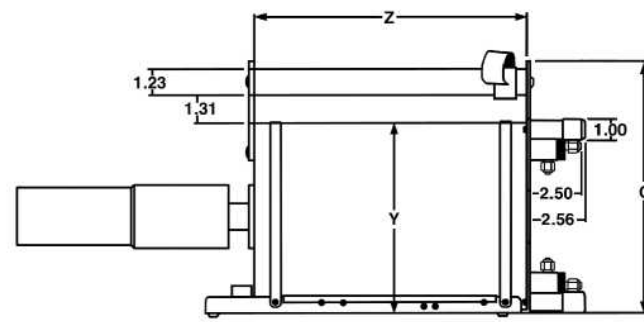

### Multi-Orientation (MOD) Dewar

#### Dewar Type

Designation	All-Attitude			Multi-Orientation (MOD)			
	LN2 Volume> Hold Time <sup>1</sup> >	1.2L 1 Day <sup>1</sup>	3L 2 Days <sup>1</sup>	5L 4 Days <sup>1</sup>	3L 2 Days <sup>1</sup>	7L 5 Days <sup>1</sup>	
Unit	Tolerance						
Q	mm	±13	229	302	302	229	302
	(in.)	±0.5	(9.0)	(11.9)	(11.9)	(9.0)	(11.9)
Y	mm	±5	157	229	229	157	229
	(in.)	±0.2	(6.2)	(9.0)	(9.0)	(6.2)	(9.0)
Z	mm	±5	229	267	419	292	320
	(in.)	±0.2	(9.0)	(10.5)	(16.5)	(11.5)	(12.6)

<sup>1</sup>Hold times are approximate for standard non-PopTop cryostats in 2.75" diameter size endcap only. Hold time for PopTop cryostats and special cryostats may vary. Actual hold times may vary depending on specific dewar, cryostat, and detector.

### Gamma Gage II Fill Options

Both the all-attitude and MOD versions of the Gamma Gage II are supplied with fill funnels to allow manual filling in a HORIZONTAL orientation. (The MOD dewar cannot be filled in vertical orientation.) Both dewar types are compatible with the ORTEC manual and automatic LN2 fill systems.

The all-attitude version may be filled in a vertical orientation or kept "at the ready" by attachment to the DWR S/F "mother cow" long term storage dewar.

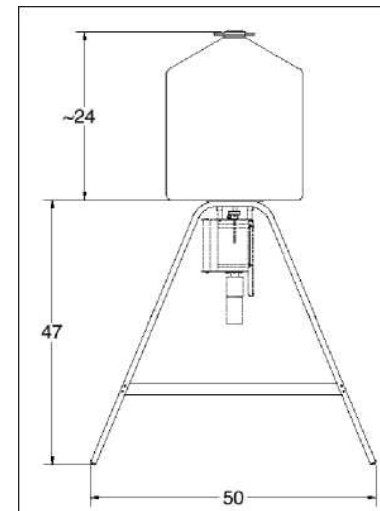

DWR S/F

Specifications subject to change  
013017

**ORTEC** <sup>®</sup> [www.ortec-online.com](http://www.ortec-online.com)  
Tel. (865) 482-4411 • Fax (865) 483-0396 • [ortec.info@ametek.com](mailto:ortec.info@ametek.com) 801  
South Illinois Ave., Oak Ridge, TN 37830 U.S.A.  
For International Office Locations, Visit Our Website

**AMETEK**  
ADVANCED MEASUREMENT  
TECHNOLOGY

### P-type Coaxial HPGe Detectors for High Performance Gamma Spectroscopy in the Energy Range of ~40 keV and Up.

The majority of gamma spectroscopy applications such as those found in counting laboratories involve the energy range ~40 keV upward. ORTEC GEM detectors are designed to cover this energy range.

All GEM Series feature:

- Efficiencies to 150%, higher on request.
- Excellent energy resolution and peak symmetry.
- SMART bias options.
- Low-background carbon fiber endcap options.
- PLUS preamplifier option for ultra-high-rate applications.
- Configuration flexibility: PopTop, Streamline and mechanically cooled options.

ORTEC offers GEM Series HPGe detectors with relative efficiencies<sup>1</sup> from 10% to 150% and beyond. The detectors are manufactured from ORTEC-grown germanium crystals processed in our advanced manufacturing facility in Oak Ridge, TN. The detectors are fabricated from P-type germanium with an outer contact of diffused Li and an inner contact of ion-implanted boron.

ORTEC maintains a stocklist of GEM detectors. Some of these have "super specifications," that is energy resolution and/or efficiency better than the usual GEM warranted specifications.

#### The Following Data are Provided with each GEM Detector

- Measured energy resolution full-width half-maximum (FWHM) at 1.33-MeV.
- Measured relative photopeak efficiency at 1.33 MeV.
- Measured Peak-to-Compton ratio at 1.33 MeV.
- Measured peak shape ratio for the full-width tenth-maximum to the FWHM at 1.33 MeV.
- Measured energy resolution at 122 keV.

### Configuration Guidelines

#### PopTop or Streamline (non-PopTop) Configuration

The essence of a PopTop detector system is that the HPGe detector element, preamplifier, and high voltage filter are housed in a detector "capsule" which is then attached to an appropriate cryostat (Figure 2.)

In Streamline systems, the detector capsule is NOT demountable. Detector capsule and cryostat share the same vacuum. In configuration terms, this requires a cryostat or cryostat/dewar selection with the cryostat having a matching diameter to the capsule endcap or an integrated cryocooling system (ICS). A cryostat or ICS must always be ordered with a Streamline capsule, because they are integral.

The actual PopTop capsule has its own vacuum. It can be mounted on any of the available cryostats, cryostat/dewar combinations, or ICS-P4 mechanical cooling system.

Certain cryostat configurations are available only as PopTop and others are available only as Streamline.

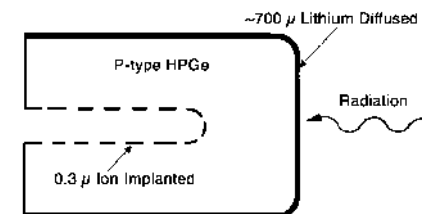

Fig. 1. Configuration of GEM Coaxial Germanium Crystal.

<sup>1</sup>By convention, HPGe detectors are characterized by "relative efficiency". Relative efficiency is defined as the efficiency of a point Co-60 source at 25 cm from the face of a standard 3-inch x 3-inch right circular cylinder NaI(Tl) detector. "IEEE Test Procedures for Germanium Detectors for Ionizing Radiation," ANSI/IEEE Standard 325-1986.

# GEM Series Coaxial HPGe Detector Product Configuration Guide

## Steps to Configure Your ORTEC HPGe Detector

### 1) Configure the Detector Model

- Capsule type (PopTop or Streamline)
- Ge Crystal efficiency and specifications
- Endcap and window
- Mount
- Preamp
- High Voltage Filter
- Cable Package
- Integrated Cryocooling System (ICS)

Options are available for the detector model that can change specific materials used in the construction of the detector endcap, cup, and mount. Preamp options are also available.

### 2) Configure the Cryostat/Dewar or ICS Model

- Vertical Dipstick style (separate Dewar or Mobius Recycler)
- Horizontal Dipstick style (separate Dewar or Mobius Recycler)
- Portable with all-position or multi-position cryostat/dewar models
- Downlooking designed to be oriented with the detector pointing down
- Sidelooking designed to be oriented with the detector horizontal at the bottom of the dewar
- "J" configurations designed with the detector attached near the bottom of the dewar and a right angle bend in the cryostat orienting the detector to look up.

A cryostat and dewar or other cooling device are required for operation.

If a PopTop detector has been selected, you can choose a PopTop style cryostat, cryostat/dewar combination or ICS-P4 mechanical cooling systems.

If a Streamline detector has been selected, you must choose a cryostat or cryostat/dewar model for the detector to be mounted on and vacuum sealed or an ICS. The cryostat, cryostat/dewar combination or ICS diameter must match the endcap diameter of the selected detector.

## Detector Options

### Integrated Cryocooling System Option (-ICS-E, -ICS-HJ)

Integrated Cryocooling System (ICS) cryostats are sealed with a cryocooler and immune to thermal short cycling. Unlike the typical three day loss of use of the detector with a standard type cryostat, an ICS can be re-cooled immediately, minimizing any time lost for temporary warm up.

### Integrated Cryocooling Low-Background System (-ICS-LB-HJ)

Low-background detector, high purity aluminum endcap, high purity aluminum window, high purity aluminum internal cup, and low-background Cu mount for the ICS Integrated Cryocooling System. The lower background material allows for lower Minimum Detectable Activity (MDA) for a specific counting time, which provides another step in increasing sample throughput in low-background applications.

### SMART-1 Option (-SMP)

The SMART-1 option monitors and reports on vital system functions, and can save authentication codes and report the code at a later time. It has the high voltage included, so none of the instruments require an external high-voltage power supply.

The SMART-1 is housed in a rugged ABS molded plastic enclosure and is permanently attached to the detector endcap via a molded-strain-relieved sealed

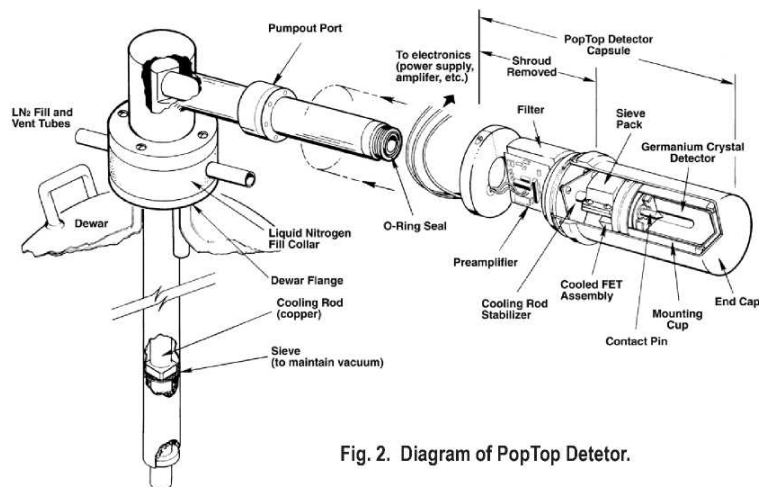

Fig. 2. Diagram of PopTop Detector.



Fig. 3. ICS Integrated Cryocooling Systems.

## GEM Series Coaxial HPGe Detector Product Configuration Guide

cable. This eliminates the possibility that the detector will suffer severe damage from moisture leaking into high-voltage connectors. The SMART-1 can be positioned in any convenient place and does not interfere with shielding or other mounting hardware.

### **Ultra-High Count-Rate Preamplifier Option (-PL)**

The Ultra-High Count-Rate Preamplifier (transistor-reset preamplifier) can handle input count rates up to 1,000,000 counts/s at 1 MeV, and offers the added benefit of having no feedback resistor.



Fig. 4. SMART-1 Detector Interface Module.

# GEM Series Coaxial HPGe Detector Product Configuration Guide

## Remote Preamplifier Option (-HJ, ICS-HJ)

This option allows all the preamplifier and high voltage connections to be outside a shield and removes the preamplifier and high voltage filter from the "line-of-sight" to the Ge crystal. For low background applications, this option eliminates any possible preamplifier or high voltage filter components that may add to the background inside a shield.

## Low-Background Carbon Fiber Endcap Options (-RB, -LB-C, and -XLB-C)

Carbon Fiber is as strong as Al, Mg, and Cu, creates less background and does not corrode.

This lower background material allows for lower Minimum Detectable Activity (MDA) for a specific counting time, which provides another step in increasing sample throughput in low-background counting applications. The lower Z of Carbon Fiber provides a low-energy window without the additional background found in most alloys. See Table 1 for transmission characteristics of the aluminum and carbon fiber windows.

Carbon Fiber, unlike Beryllium, is non-toxic and can be cleaned with most laboratory solvents such as methanol, trichloroethylene, and acetone. Soap and water may also be used. Abrasive cleaners should not be used.

Table 1. Percentage of Photons Transmitted as a Function of Energy

Energy (keV)	Aluminum Window % Transmission	Carbon Fiber Window % Transmission
3	0	0.29
5	0	23
10	0.09	82
20	40	97
30	74	99
50	91	100
80	95	100
100	96	100
400	97	100
1000	98	100

# GEM Series Coaxial HPGe Detector Product Configuration Guide

## PopTop Detector Capsule

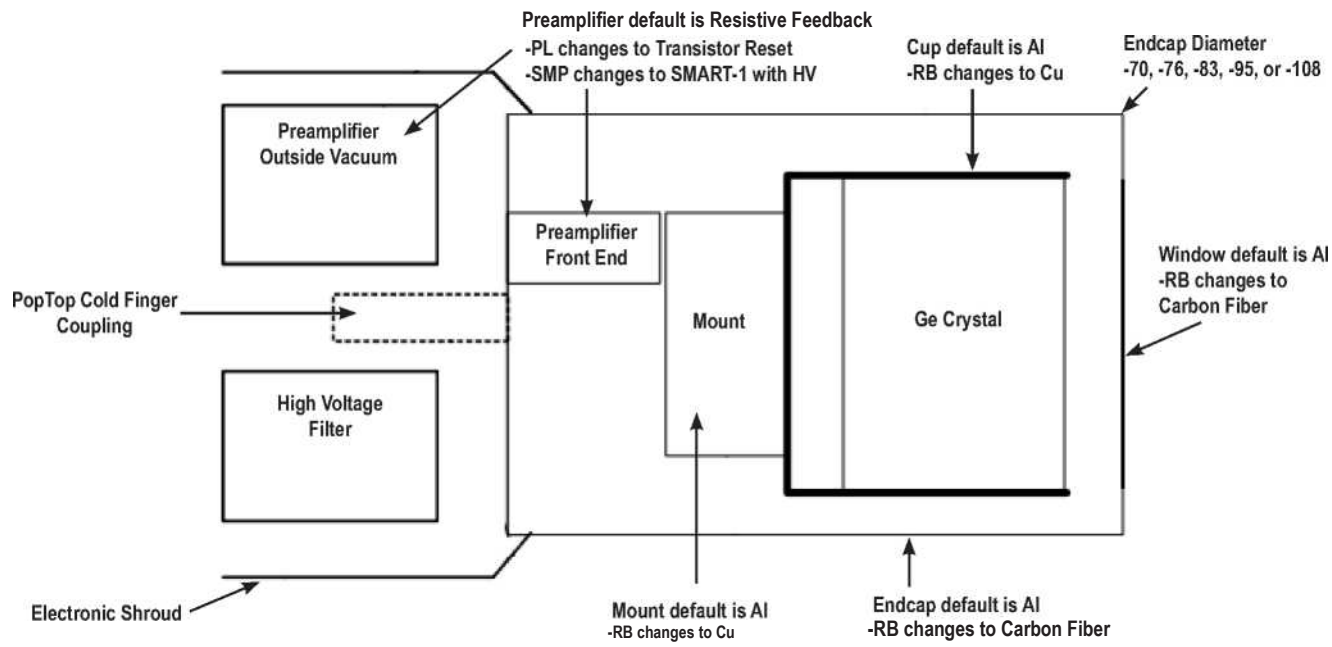

## Streamline Detector Capsule

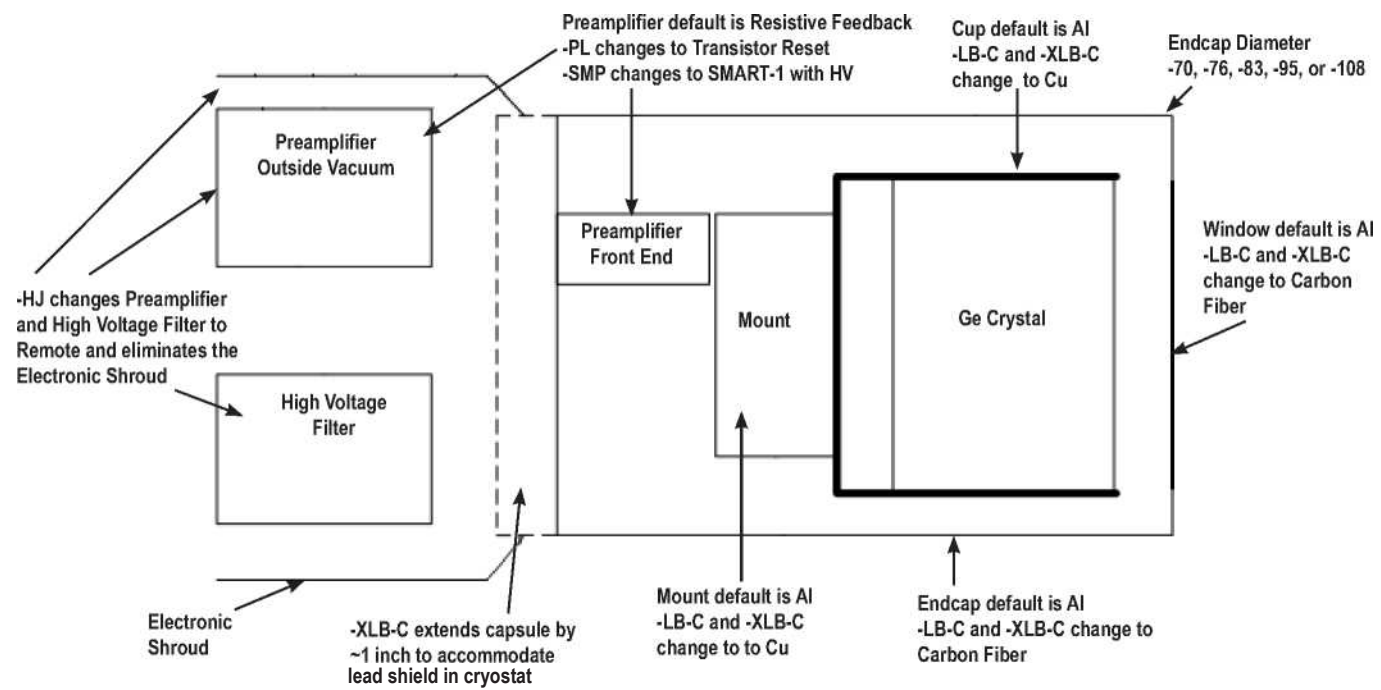

# GEM Series Coaxial HPGe Detector Product Configuration Guide

## Streamline Detector Capsule for Integrated Cryocooling System with External Preamp (ICS-E)

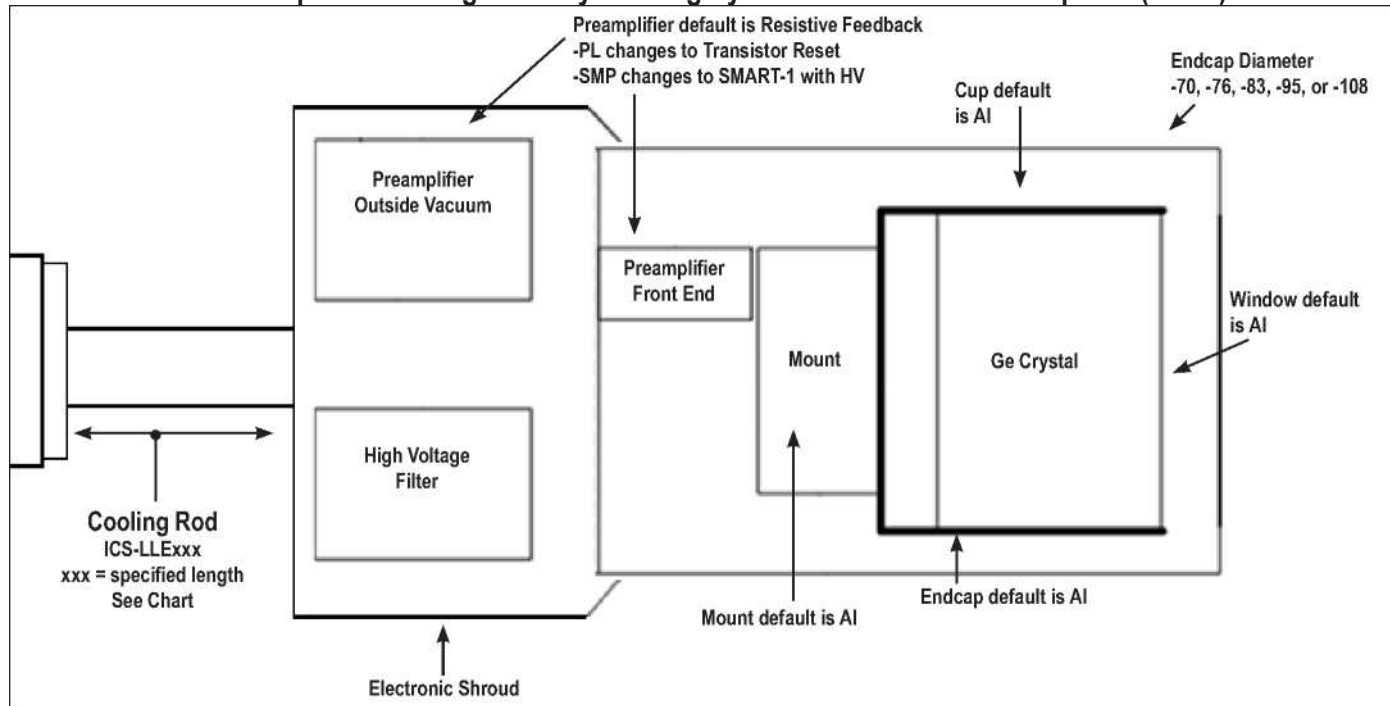

## Streamline Detector Capsule for Integrated Cryocooling System with Remote Preamp (ICS-HJ)

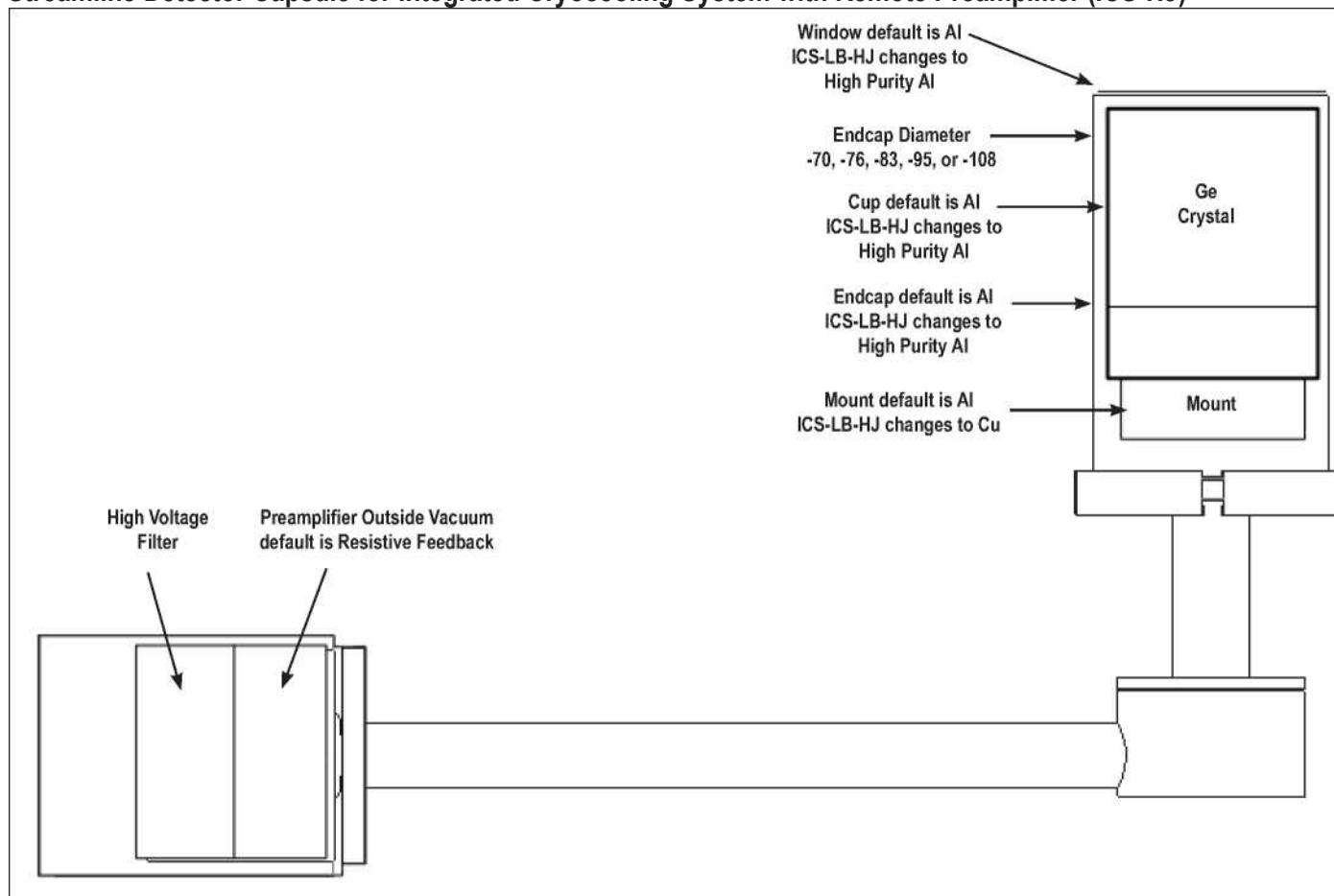

# GEM Series Coaxial HPGe Detector Product Configuration Guide

## **Streamline Cryostat and Cryostat/Dewar Assemblies**

Streamline systems (detector capsule and cryostat) share the same vacuum, requiring a cryostat or cryostat/dewar selection with the cryostat having a matching diameter to the capsule endcap.

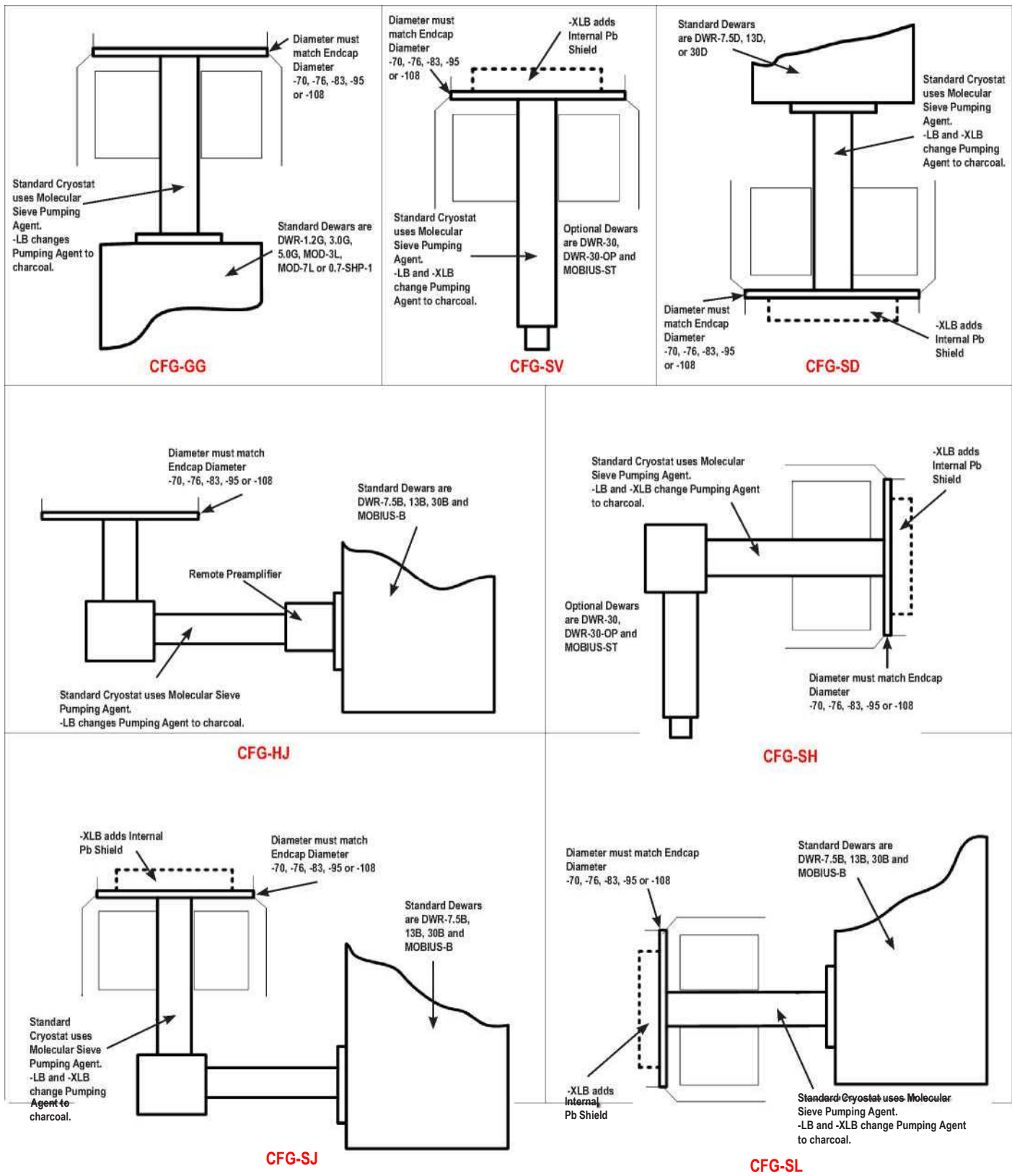

# GEM Series Coaxial HPGe Detector Product Configuration Guide

## PopTop and Streamline Dimensional Data

Streamline systems (detector capsule and cryostat or ICS) share the same vacuum. A cryostat or ICS must be ordered with a Streamline capsule. The cryostat or cryostat/dewar selection must have a matching diameter to the capsule endcap.

The PopTop capsule features an internal vacuum arrangement. It can be mounted on any of the available PopTop cryostats, cryostat/dewar combinations, or ICS-P4 mechanical cooling systems.

The cryostat and dewar drawings that follow are to be used in conjunction with the accompanying tables of dimensions.

**Note: Cryostat/Dewar drawings are NOT to scale, see tables that follow for complete dimensions.  
Dimensions are for reference only and subject to change, if dimensional constraints are critical, contact the factory.**

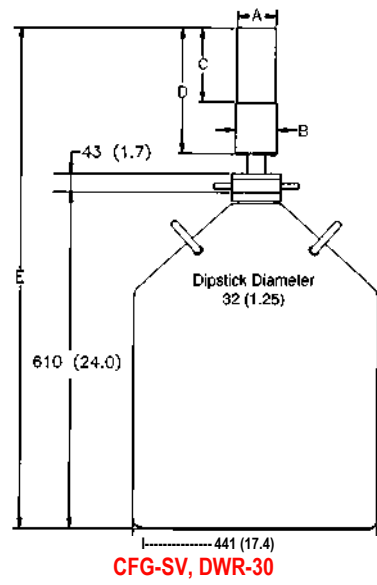

**CFG-SV, DWR-30**

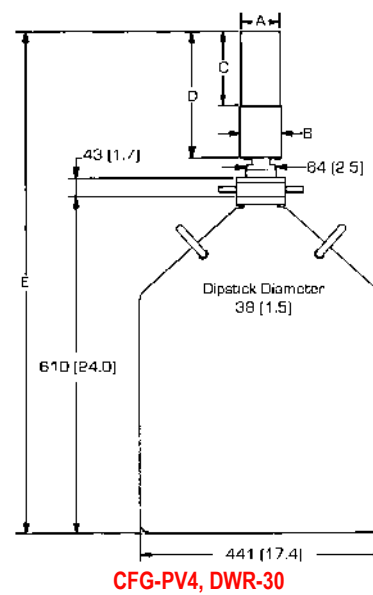

**CFG-PV4, DWR-30**

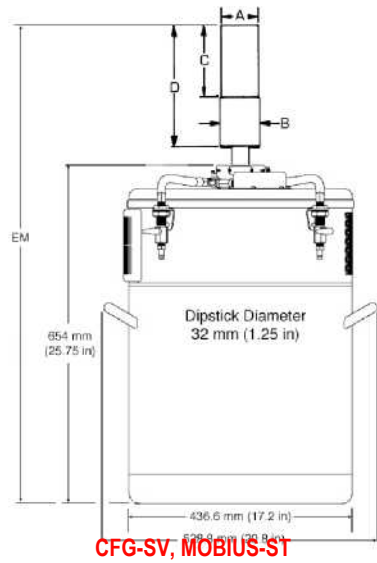

**CFG-SV, MOBIUS-ST**

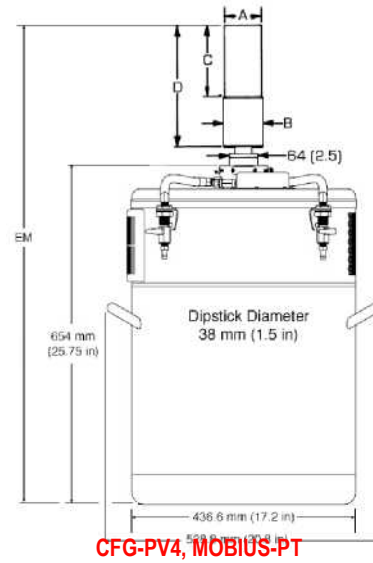

**CFG-PV4, MOBIUS-PT**

# **GEM Series Coaxial HPGe Detector Product Configuration Guide**

# GEM Series Coaxial HPGe Detector Product Configuration Guide

Note: Cryostat/Dewar drawings are NOT to scale, see tables that follow for complete dimensions.  
Dimensions are for reference only and subject to change, if dimensional constraints are critical, contact the factory.

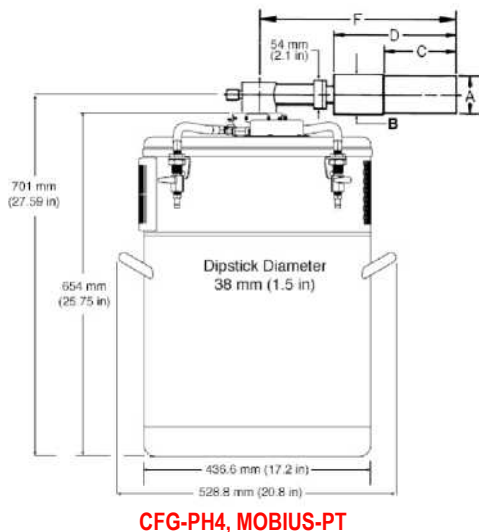
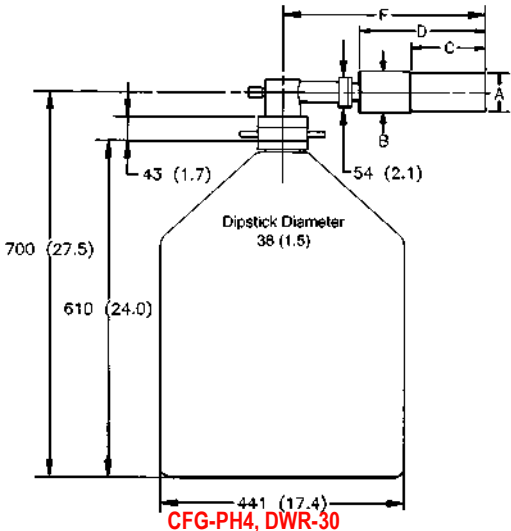
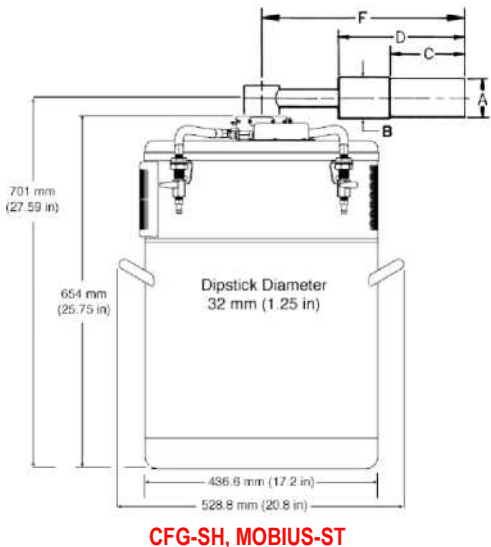
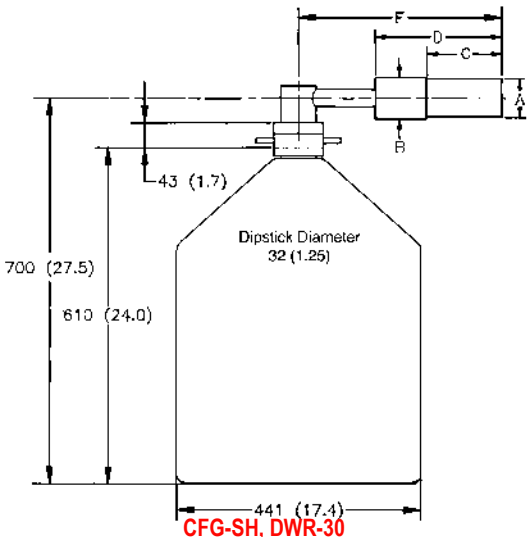

# GEM Series Coaxial HPGe Detector Product Configuration Guide

Note: Cryostat/Dewar drawings are NOT to scale, see tables that follow for complete dimensions.  
Dimensions are for reference only and subject to change, if dimensional constraints are critical, contact the factory.

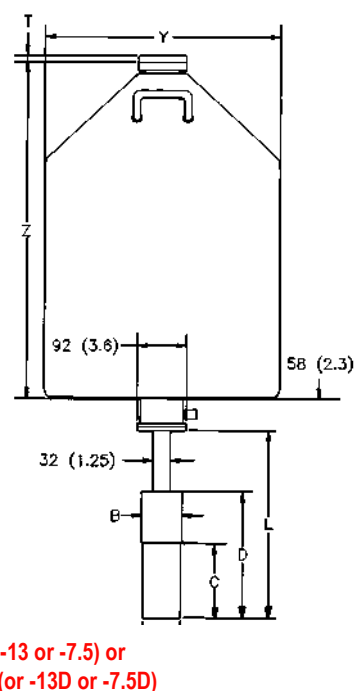
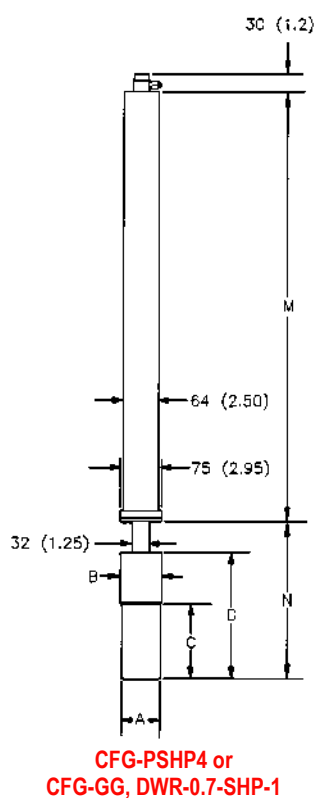
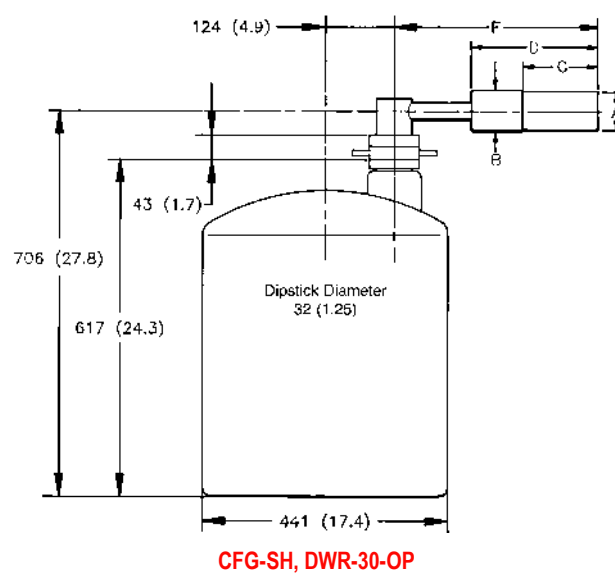
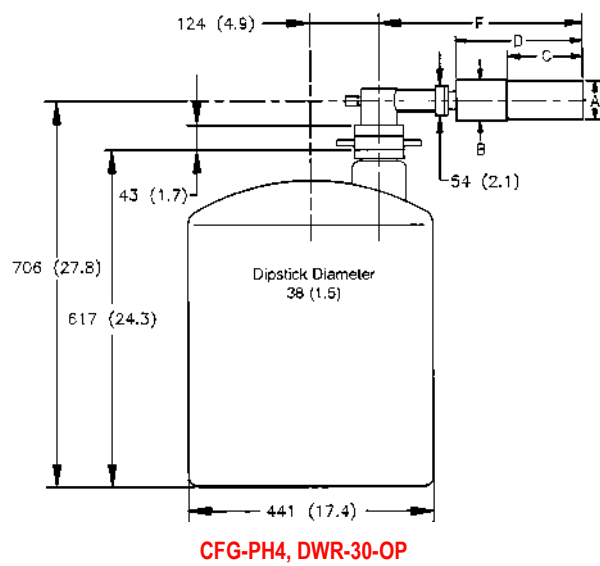

# GEM Series Coaxial HPGe Detector Product Configuration Guide

Note: Cryostat/Dewar drawings are NOT to scale, see tables that follow for complete dimensions.  
Dimensions are for reference only and subject to change, if dimensional constraints are critical, contact the factory.

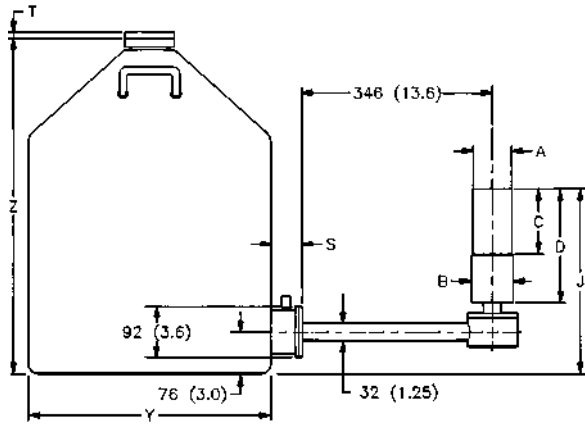

CFG-SJ, DWR-30B (or -13B or -7.5B)

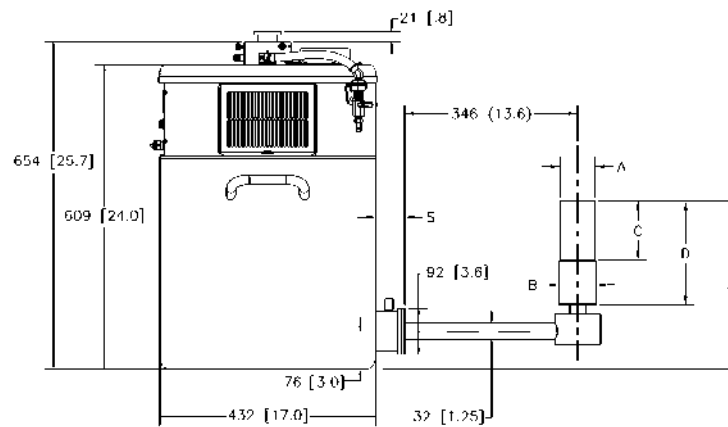

CFG-SJ, MOBIUS-B

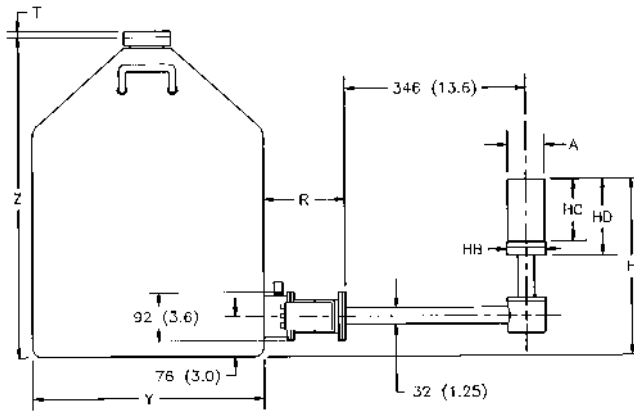

CFG-HJ, DWR-30B (or -13B or -7.5B)

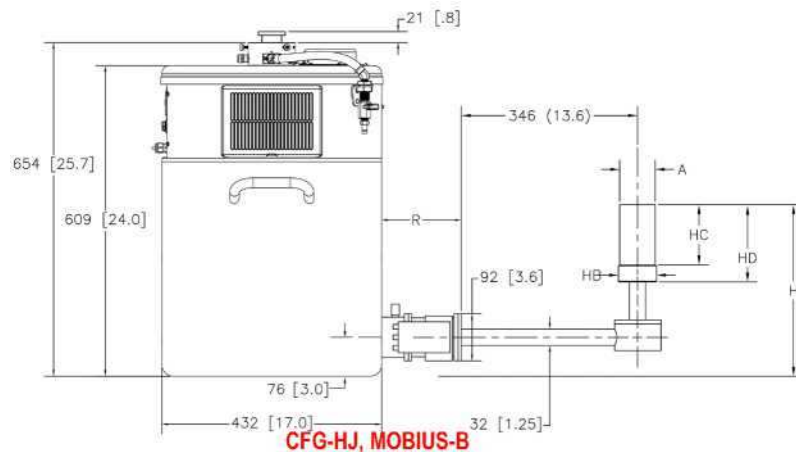

CFG-HJ, MOBIUS-B

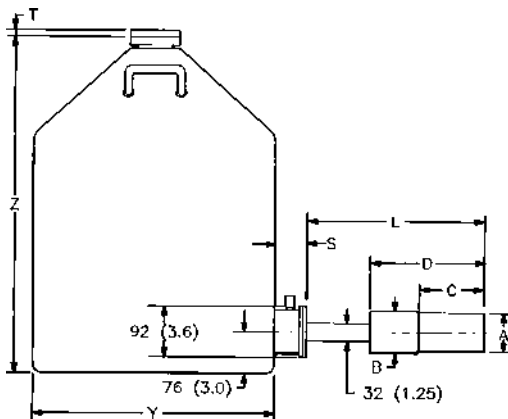

CFG-PS4-30 (or -13 or -7.5) or  
CFG-SL, DWR-30B (or -13B or -7.5B)

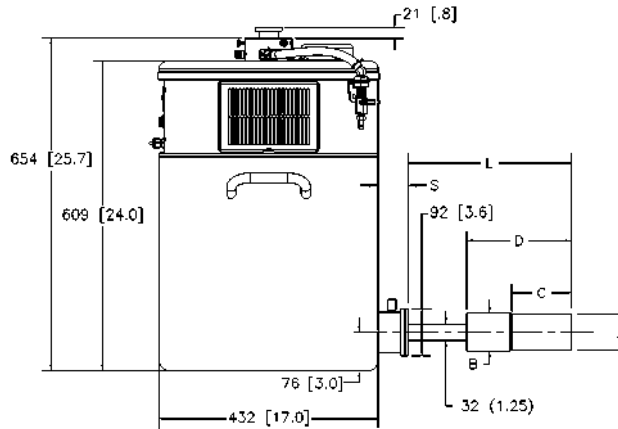

CFG-PS4-MOBIUS-B or CFG-SL, MOBIUS-B

# GEM Series Coaxial HPGe Detector Product Configuration Guide

Note: Cryostat/Dewar drawings are NOT to scale, see tables that follow for complete dimensions.  
Dimensions are for reference only and subject to change, if dimensional constraints are critical, contact the factory.

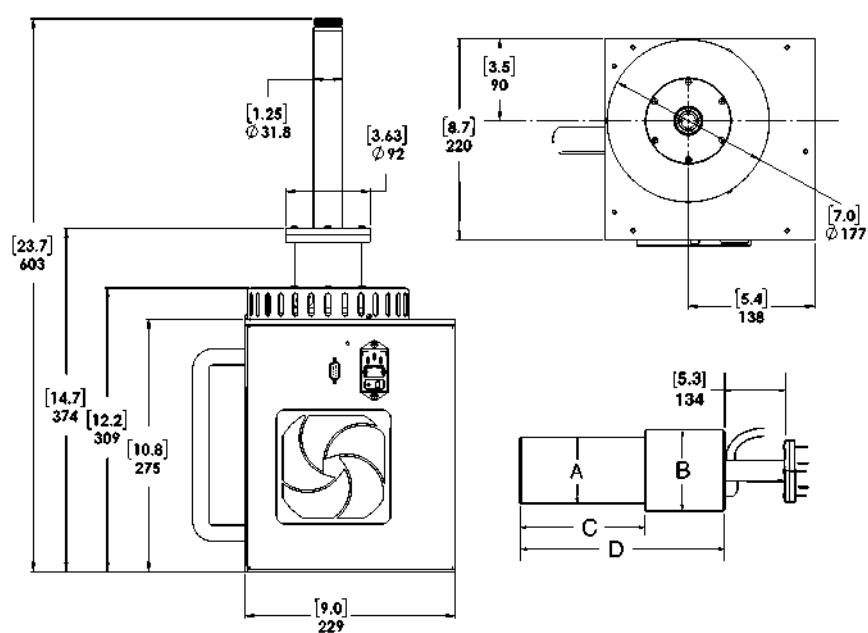

CFG-ICS-P4

## PopTop GEM Detector Dimensions

- Dimensions are for reference only and subject to change.
- If dimensional constraints are critical, contact the factory.

Endcap Model (dia. mm)			-70	-76	-83	-95	-108
% Efficiencies available in this endcap size			0-20	25-40	45-55	60-110	120-150
Dim.	Unit	Tol.					
A	mm (in)	0.3 (0.01)	70 (2.75)	76 (3.0)	83 (3.25)	95 (3.75)	108 (4.25)
B	mm (in)	0.3 (0.01)	75 (2.95)	88 (3.45)	88 (3.45)	100 (3.95)	113 (4.45)
C	mm (in)	5 (0.2)	134 (5.3)	165 (6.4)	168 (6.6)	193 (7.6)	207 (8.2)
D	mm (in)	8 (0.3)	250 (9.8)	282 (11.2)	282 (11.2)	309 (12.2)	323 (12.7)
E	mm (in)	18 (0.7)	947 (37.3)	982 (38.6)	982 (38.6)	1007 (39.7)	1019 (40.1)
EM	mm (in)	19 (0.75)	948 (37.3)	983 (38.7)	983 (38.7)	1008 (39.7)	1020 (40.1)
F	mm (in)	10 (0.4)	396 (15.6)	429 (16.9)	429 (16.9)	455 (17.9)	469 (18.5)
L	mm (in)	10 (0.4)	338 (13.3)	371 (14.6)	371 (14.6)	396 (15.6)	412 (16.2)
M	mm (in)	8 (0.3)	790 (31.1)	X	X	X	X
N	mm (in)	10 (0.4)	278 (10.9)	312 (12.3)	312 (12.3)	338 (13.3)	348 (13.7)

# GEM Series Coaxial HPGe Detector Product Configuration Guide

## Streamline GEM Detector Dimensions

- Dimensions are for reference only and subject to change.
- If dimensional constraints are critical, contact the factory.

Endcap Model (dia. mm)			Standard or LB					XLB				
			-70	-76	-83	-95	-108	-70	-76	-83	-95	-108
% Efficiencies available in this endcap size			0-20	25-40	45-55	60-110	120-150	0-20	25-40	45-55	60-110	120-150
Dim.	Unit	Tol.										
A	mm (in)	0.3 (0.01)	70 (2.75)	76 (3.0)	83 (3.25)	95 (3.75)	108 (4.25)	70 (2.75)	76 (3.0)	83 (3.25)	95 (3.75)	108 (4.25)
B	mm (in)	0.3 (0.01)	75 (2.95)	88 (3.45)	88 (3.45)	100 (3.95)	113 (4.45)	75 (2.95)	88 (3.45)	88 (3.45)	100 (3.95)	113 (4.45)
C	mm (in)	5 (0.2)	134 (5.3)	132 (5.2)	134 (5.3)	160 (6.3)	197 (7.8)	160 (6.3)	157 (6.1)	160 (6.3)	185 (7.3)	197 (7.8)
D	mm (in)	8 (0.3)	246 (9.7)	259 (10.2)	259 (10.2)	284 (11.2)	322 (12.7)	272 (10.7)	284 (11.2)	284 (11.2)	310 (12.2)	322 (12.7)
E	mm (in)	18 (0.7)	916 (36.1)	932 (36.7)	932 (36.7)	957 (37.7)	995 (39.2)	941 (37.1)	958 (37.7)	958 (37.7)	983 (38.7)	995 (39.2)
EM	mm (in)	19 (0.75)	917 (36.1)	933 (36.7)	933 (36.7)	958 (37.7)	996 (39.2)	942 (37.1)	959 (37.8)	959 (37.8)	984 (38.7)	996 (39.2)
F	mm (in)	10 (0.4)	368 (14.5)	381 (15.0)	381 (15.0)	406 (16.0)	445 (17.5)	394 (15.5)	406 (16.0)	406 (16.0)	432 (17.0)	445 (17.5)
H	mm (in)	18 (0.7)	351 (13.8)	364 (14.3)	364 (14.3)	390 (15.3)	428 (16.9)	X X	X X	X X	X X	X X
HB	mm (in)	0.3 (0.1)	73 (2.9)	85 (3.4)	85 (3.4)	98 (3.9)	111 (4.4)	X X	X X	X X	X X	X X
HC	mm (in)	5 (0.2)	134 (5.3)	132 (5.2)	135 (5.3)	160 (6.3)	199 (7.8)	X X	X X	X X	X X	X X
HD	mm (in)	10 (0.4)	162 (6.4)	175 (6.9)	175 (6.9)	200 (7.9)	238 (9.4)	X X	X X	X X	X X	X X
J	mm (in)	10 (0.4)	380 (15)	393 (15.5)	393 (15.5)	418 (16.5)	456 (18)	405 (16)	418 (16.5)	418 (16.5)	444 (17.5)	456 (18)
L	mm (in)	10 (0.4)	338 (13.3)	351 (13.8)	351 (13.8)	376 (14.8)	414 (16.3)	363 (14.3)	376 (14.8)	376 (14.8)	401 (15.8)	414 (16.3)
M	mm (in)	8 (0.3)	516 (20.3)	X X	X X	X X	X X	516 (20.3)	X X	X X	X X	X X
N	mm (in)	10 (0.4)	278 (11)	292 (11.5)	292 (11.5)	318 (12.5)	355 (14)	305 (12)	318 (12.5)	318 (12.5)	243 (13.5)	355 (14)

# GEM Series Coaxial HPGe Detector Product Configuration Guide

Note: Cryostat/Dewar drawings are NOT to scale, see tables that follow for complete dimensions.  
Dimensions are for reference only and subject to change, if dimensional constraints are critical, contact the factory.

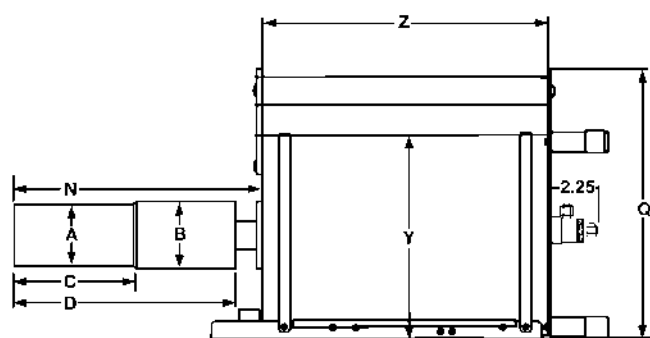

CFG-PG4-1.2 (or -3 or -5) or  
CFG-GG, DWR-1.2G (or -3.0G, -5.0G)

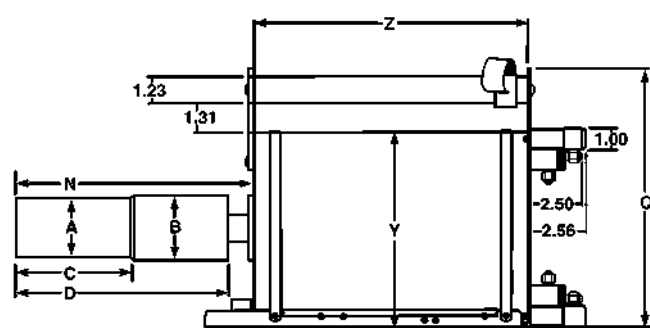

CFG-PMOD4-3 (or -7) or  
CFG-GG, DWR-MOD3L (or -MOD7L)

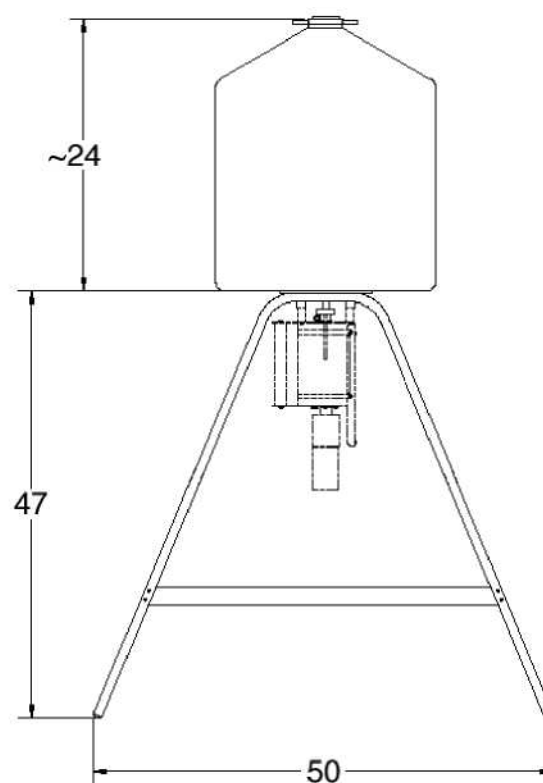

DWR-S/F

## Gamma Gage and Side-Looking Dewar Dimensions

- Dimensions are for reference only and subject to change.
- If dimensional constraints are critical, contact the factory.

			Cryostat/Dewar or Dewar Type							
			CFG-PG4 and DWR-x.xG			CFG-PMOD4 and DWR-MOD-xL		CFG-PS4, CFG-PD4, DWR-xxB and DWR-xxD		
			VOLUME			VOLUME		VOLUME		
Dim.	Unit	Tol. ±	1.2L	3L	5L	3L	7L	7.5L	13L	30L
Q	mm (in)	13 (0.5)	229 (9.0)	302 (11.9)	302 (11.9)	229 (9.0)	302 (11.9)	X X	X X	X X
R	mm (in)	10 (0.4)	X X	X X	X X	X X	X X	174 (6.9)	174 (6.9)	155 (6.1)
S	mm	7.6	X	X	X	X	X	77	77	60

# GEM Series Coaxial HPGe Detector Product Configuration Guide

	(in)	(0.3)	X	X	X	X	X	(3.0)	(3.0)	(2.3)
T	mm (in)	5 (0.2)	X X	X X	X X	X X	X X	10 (0.4)	10 (0.4)	13 (0.5)
Y	mm (in)	13 (0.5)	157 (6.2)	229 (9.0)	229 (9.0)	157 (6.2)	229 (9.0)	224 (8.8)	307 (12.1)	442 (17.4)
Z	mm (in)	5 (0.2)	229 (9.0)	267 (10.5)	419 (16.5)	292 (11.5)	320 (12.6)	452 (17.8)	429 (16.9)	610 (24.0)

# GEM Series Coaxial HPGe Detector Product Configuration Guide

Note: Cryostat/Dewar drawings are NOT to scale, see tables that follow for complete dimensions.  
Dimensions are for reference only and subject to change, if dimensional constraints are critical, contact the factory.

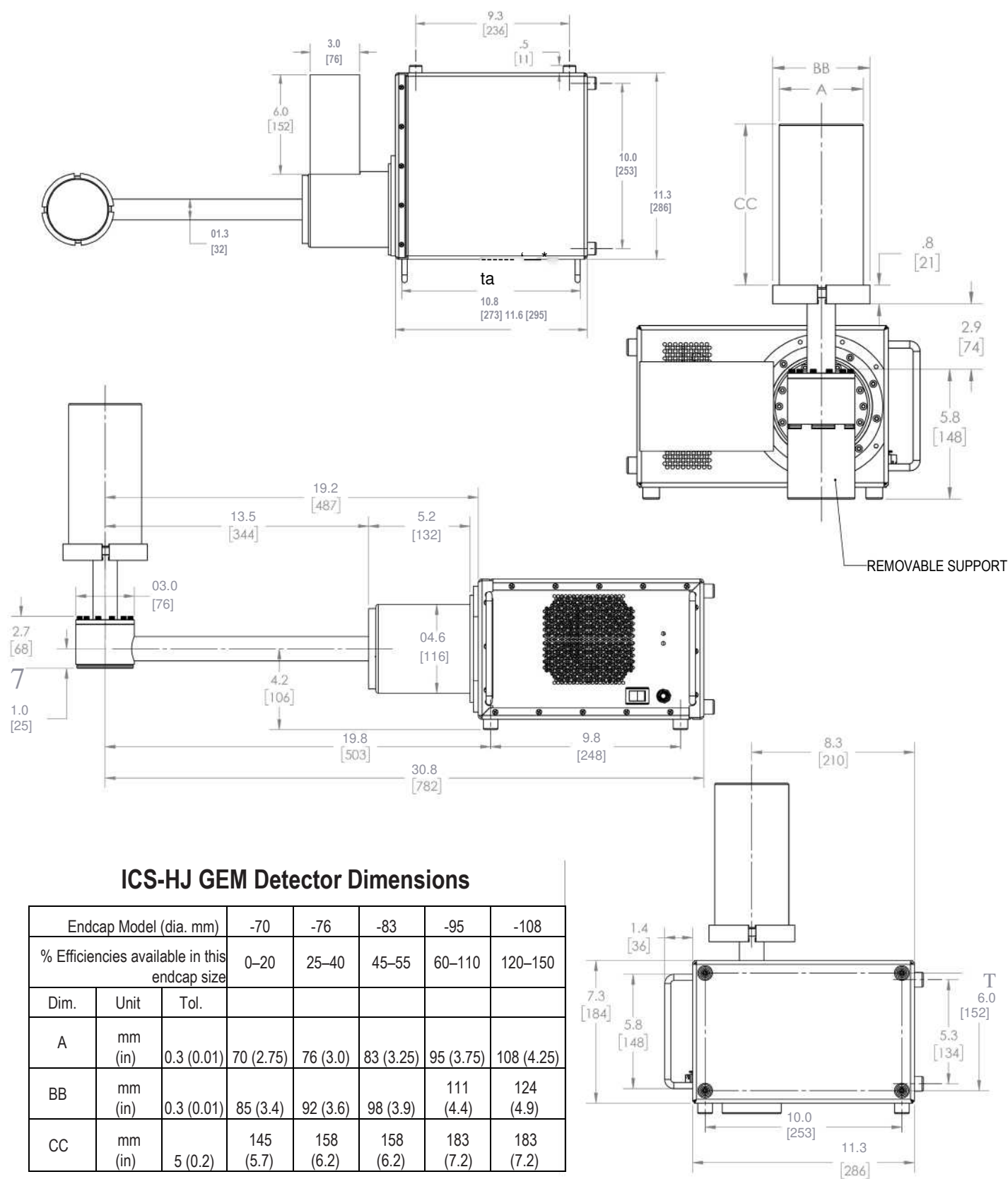

# GEM Series Coaxial HPGe Detector Product Configuration Guide

**Note: Cryostat/Dewar drawings are NOT to scale, see tables that follow for complete dimensions.  
Dimensions are for reference only and subject to change, if dimensional constraints are critical, contact the factory.**

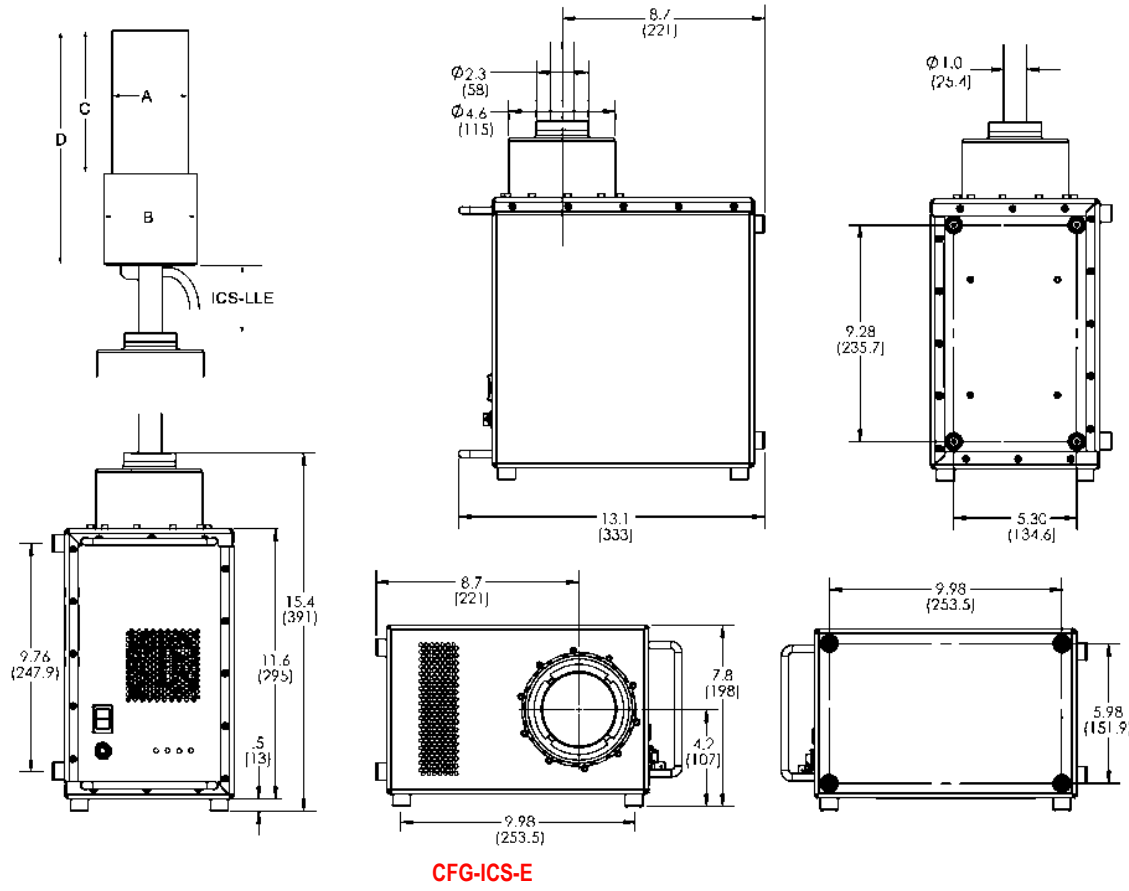

## Streamline GEM Detector Dimensions for ICS-E Integrated Cryocooling System

- Dimensions are for reference only and subject to change.
- If dimensional constraints are critical, contact the factory.

Endcap Model (dia. mm)			-70	-76	-83	-95	-108
% Efficiencies available in this endcap size			0-20	25-40	45-55	60-110	120-150
Dim.	Unit	Tol.					
A	mm (in)	0.3 (0.01)	70 (2.75)	76 (3.0)	83 (3.25)	95 (3.75)	108 (4.25)
B	mm (in)	0.3 (0.01)	101 (4.0)	101 (4.0)	101 (4.0)	114 (4.4)	127 (5.0)
C	mm (in)	5 (0.2)	144 (5.7)	157 (6.2)	157 (6.2)	182 (7.2)	182 (7.2)
D	mm (in)	5 (0.2)	243 (9.6)	256 (10.1)	256 (10.1)	281 (11.1)	281 (11.1)
ICS-LLE	mm	3	Specify length. Choose from 025, 114, 139, 190.*				

\*Recommended cooling rod length (ICS-LLE): 139 mm for use with 4" lead shield; 190 mm for use with 6" lead shield. Other lengths available by special order.

# GEM Series Coaxial HPGe Detector Product Configuration Guide

## GEM Endcap Diameter and Window

The endcap size must be specified by adding the endcap Model (-xx) to the Detector Model (e.g., GEM25-76 or GEM60P4-95).  
If this, or any other dimension is critical, please specify at time of order.

Endcap Model (dia. mm)	-70	-76	-83	-95	-108
Endcap Diameter (in)	2.75	3.00	3.25	3.75	4.25
Efficiency	0–20%	25–40%	45–55%	60–110%	120–150%
Thickness of Al Window	1 mm	1 mm	1 mm	1.5 mm	1.5 mm
Thickness of CF Window	.9 mm nominal	.9 mm nominal	.9 mm nominal	.9 mm nominal	.9 mm nominal

# GEM Series Coaxial HPGe Detector Product Configuration Guide

## Defining the Detector Model

- See ordering information for option compatibility.

Base Model (example)	PopTop or Streamline	Endcap Diameter	ICS Option (if required)	Window Option (if required)	Preamplifier Option (if required)	High Voltage Option (if required)
GEM10	P4 (PopTop) (Streamline)	-70 -76 -83 -95 -108	-ICS-E -ICS-HJ -ICS-LB-HJ	-RB -LB-C -XLB-C	-PL -HJ	-SMP

## Example Model Numbers

### PopTop Configuration

GEM10P4-70	10% efficiency GEM detector with 70-mm diameter endcap.
CFG-PH4 MOBIUS-PT	Horizontal Dipstick type cryostat. Möbius Recycler.
GEM40P4-76-SMP CFG-PD4-7.5	40% efficiency GEM detector with 76-mm diameter endcap and SMART-1 preamplifier and high voltage supply. Downlooking cryostat with 7.5 liter dewar.
GEM50P4-83-RB-SMP	50% efficiency GEM detector with 83-mm diameter reduced background carbon fiber endcap and SMART-1 preamplifier and high voltage supply.
CFG-PV4 DWR-30	Vertical "dipstick" style cryostat. 30 liter top port dewar that accepts "dipstick" style cryostats.
GEM80P4-95	80% efficiency GEM detector with 95-mm diameter endcap. Integrated Cryocooling System

### Streamline Configuration

GEM10-70	10% efficiency GEM detector with 70-mm diameter endcap.
CFG-GG-70	Portable Gamma Gage cryostat with matching 70-mm diameter flange.
DWR-1.2G	1.2 liter all-position dewar for Gamma Gage cryostat.
GEM40-76-SMP	40% efficiency GEM detector with 76-mm diameter endcap and SMART-1 preamplifier and high voltage supply.
CFG-SD-76	Down-looking cryostat with matching 76-mm diameter flange.
DWR-7.5D	7.5 liter down-looking dewar.
GEM50-83-HJ	50% efficiency GEM detector with 83-mm diameter endcap and remote preamplifier and high voltage filter.
CFG-HJ-83	"J" configuration cryostat with matching 83-mm diameter flange, and remote fittings for the preamplifier and high voltage filter.
DWR-30B	30 liter side-looking dewar for "HJ" cryostat.

### Streamline with Integrated Cryocooling System (ICS) Configuration

GEM40-76-ICS-E-SMP	40% efficiency GEM detector with 76-mm diameter endcap in an ICS integrated cryocooling system with external preamp, SMART-1 preamplifier and high voltage supply.
CFG-ICS-E ICS-LLE114-76	Integrated Cryocooling System with external preamp. 114-mm cooling rod length with matching 76-mm diameter flange.
GEM50-83-ICS-HJ	50% efficiency GEM detector with 83-mm diameter endcap in an ICS-HJ integrated cryocooling system with remote preamp and high voltage filter.
GEM100-95-ICS-LB-HJ	100% efficiency GEM detector with 95-mm diameter endcap in an ICS-LB-HJ integrated cryocooling low-background system with remote preamp and high voltage filter, low-background high purity aluminum endcap and OFHC Cu mount.

# GEM Series Coaxial HPGe Detector

## Product Configuration Guide

### Ordering Information and Warranted Specifications

- Endcap Diameter must be specified. See Defining the Detector Model on page 17.
- Cryostat and dewar or other cooling device are not included with detector and are required for operation.
- A cryostat must be ordered with a Streamline detector.
- Monte Carlo drawing and certified factory test results are included.

Base Model No.	Relative Photopeak Efficiency (%) (Minimum)	Resolution		Peak-to-Compton Ratio (Minimum)	Peak Shape*		Endcap Diameter (mm) Nominal
		@122 keV (keV) FWHM (Maximum)	@1.33 MeV (keV) FWHM (Maximum)		FW.1M/ FWHM (Maximum)	FW.02M/ FWHM (Typical)	
GEM10	10	0.80	1.7	41:1	1.9	2.6	-70
GEM15	15	0.82	1.8	46:1	1.9	2.6	-70
GEM20	20	0.82	1.8	52:1	1.9	2.6	-70
GEM25	25	0.82	1.8	56:1	1.9	2.6	-76
GEM30	30	0.85	1.8	60:1	1.9	2.6	-76
GEM40	40	0.87	1.8	64:1	1.9	2.6	-76
GEM50	50	0.90	1.9	66:1	1.9	2.6	-83
GEM60	60	1.00	1.9	70:1	1.9	3.0	-95
GEM70	70	1.00	2.0	75:1	2.0	3.0	-95
GEM80	80	1.10	2.0	77:1	2.0	3.0	-95
GEM90	90	1.20	2.0	80:1	2.0	3.0	-95
GEM100	100	1.20	2.1	83:1	2.0	3.0	-95
GEM110	110	1.30	2.1	85:1	2.0	3.0	-95
GEM120	120	1.30	2.1	86:1	2.0	3.1	-108
GEM130	130	1.30	2.1	90:1	2.0	3.1	-108
GEM140	140	1.30	2.2	90:1	2.0	3.1	-108
GEM150	150	1.30	2.3	90:1	2.0	3.1	-108

Notes:

- 1) FWHM = Full Width at Half Maximum; FW.1M = Full Width at One-Tenth Maximum; FW.02M = Full Width at One-Fiftieth Maximum; total system resolution measured at the factory in accordance with ANSI/IEEE Std. 325-1996.
- 2) Measured at optimal shaping time using an ORTEC DSPEC-50A.

# GEM Series Coaxial HPGe Detector Product Configuration Guide

## GEM Detector Options

- Append suffix to base model number.
- Endcap Diameter must be specified. See Defining the Detector Model on page 17.

Suffix	Description
P4	<u>PopTop Only</u> . PopTop capsule, add "P4" to the model number.
-RB	<u>PopTop Only</u> . Reduced background PopTop capsule with Carbon Fiber endcap, add "-RB" to the model number.
-LB-C	<u>Streamline Only</u> . Low-Background Detector with Carbon Fiber Endcap, add "-LB-C" to the model number. Requires selection of a Low-Background LB cryostat.
-XLB-C	<u>Streamline Only</u> . Extra-Low-Background Detector with Carbon Fiber Endcap, add "-XLB-C" to the model number. Requires selection of a Low-Background XLB cryostat.
-HJ	<u>Streamline Only</u> . Remote preamplifier and high voltage filter for use with HJ type cryostat, add "-HJ" to the model number. Requires selection of HJ cryostat. Not compatible with -PL or -SMP options.
-ICS-E	<u>ICS Streamline Only</u> . Integrated Cryocooling System with external preamp. Cryostat sealed with a cryocooler and immune to thermal short cycling, add "-ICS-E" to the model number. Requires selection of an ICS-E cryostat.
-ICS-HJ	<u>ICS Streamline Only</u> . Integrated Cryocooling System with remote preamp and high voltage filter. Cryostat sealed with a cryocooler and immune to thermal short cycling, add "-ICS-HJ" to the model number. This option is inclusive of cryostat and does not require selection of an additional cryostat. Not compatible with other options.
-ICS-LB-HJ	<u>ICS Streamline Only</u> . Integrated Cryocooling System with remote preamp and high voltage filter, High Purity Al Endcap and Cu Mount. Cryostat sealed with a cryocooler and immune to thermal short cycling, add "-ICS-HJ" to the model number. This option is inclusive of cryostat and does not require selection of an additional cryostat. Not compatible with other options.
-PL	PLUS Ultra-high-count-rate Preamplifier, add "-PL" to the model number. Not compatible with -HJ option.
-SMP	SMART-1 detector option for positive bias detector, add "-SMP" to the model number. Not compatible with -HJ option.

# GEM Series Coaxial HPGe Detector Product Configuration Guide

## GEM PopTop Cryostats and Dewars

Model No.	Description
CFG-MG4-1.2G	Gamma Gage Cryostat with 1.2-liter Dewar, Pistol Grip handle and mounting holes to fit the M-1-T1 Tripod (for 83 mm or smaller endcaps)
CFG-PD4-7.5	Down-looking Cryostat with 7.5-liter Dewar
CFG-PD4-13	Down-looking Cryostat with 13-liter Dewar
CFG-PD4-30	Down-looking Cryostat with 30-liter Dewar
CFG-PG4-1.2	Gamma Gage Cryostat with 1.2-liter Dewar (for 83 mm or smaller endcaps)
CFG-PG4-3	Gamma Gage Cryostat with 3-liter Dewar
CFG-PG4-5	Gamma Gage Cryostat with 5-liter Dewar
CFG-PH4	Horizontal Cryostat (Dipstick type). Choose DWR-30, DWR-30-OP, MOBIUS-PT or MOBIUS-PT-DET.
CFG-PMOD4-3	Gamma Gage Cryostat with 3-liter Multi-Orientation Dewar
CFG-PMOD4-7	Gamma Gage Cryostat with 7-liter Multi-Orientation Dewar
CFG-PS4-7.5	Side-Looking Cryostat with 7.5-liter Dewar
CFG-PS4-13	Side-Looking Cryostat with 13-liter Dewar
CFG-PS4-30	Side-Looking Cryostat with 30-liter Dewar
CFG-PS4-MOBIUS-B	Side-Looking Cryostat with Möbius Recycler 28-liter Dewar
CFG-PS4-MOBIUS-B-DET	Side-Looking Cryostat with Möbius Recycler 28-liter Dewar for purchase in combination with any PopTop detector.
CFG-PSHP4	Down-Looking Shallow-Hole Probe with 0.7-liter Dewar
CFG-PV4	Vertical Cryostat (Dipstick type). Choose DWR-30, DWR-30-OP, MOBIUS-PT or MOBIUS-PT-DET.
CFG-ICS-P4	Integrated Cryocooling System
MOBIUS-PT	Möbius Recycler.
MOBIUS-PT-DET	Möbius Recycler Dewar for purchase in combination with any PopTop detector and vertical or horizontal dipstick cryostat.
DWR-30	30-liter Dewar. Includes collar for 1.5" diameter cryostat.
DWR-30-OP	30-liter Offset-Port Dewar. Includes collar for 1.5" diameter cryostat.
DWR-S/F	Storage Fill Dewar for CFG-PG4-X

# GEM Series Coaxial HPGe Detector Product Configuration Guide

## GEM Streamline Cryostats

- May only be purchased with a detector.
- Append matching Detector Endcap Size designation to cryostat model: -70, -76, -83, -95, -108 [e.g., CFG-SJ-95 for GEM80-95, or CFG-SL-XLB-76 for GEM30-76-XLB-C]
- Dewar required. Select dewar from GEM Streamline Dewars.
- Horizontal and Vertical Cryostats include CFG-ADAPTOR to increase cryostat diameter from 1.25 inch to 1.5 inch for use with DWR-30 and DWR-30-OP.

Model No.	Description
CFG-GG	Gamma Gage Cryostat
CFG-HJ	J-type Cryostat with Remote Preamp. (for -HJ option only)
CFG-SD	Down-Looking Cryostat
CFG-SH	Horizontal Cryostat (Dipstick type).
CFG-SJ	J-type Cryostat
CFG-SL	Side-Looking Cryostat
CFG-SV	Vertical Cryostat (Dipstick type).

## LOW-BACKGROUND

CFG-GG-LB	Low-Background Gamma Gage Cryostat
CFG-HJ-LB	Low-Background J-type Cryostat with Remote Preamp. (for -HJ option only)
CFG-SD-LB	Low-Background Down-Looking Cryostat
CFG-SH-LB	Low-Background Horizontal Cryostat (Dipstick type).
CFG-SJ-LB	Low-Background J-type Cryostat
CFG-SL-LB	Low-Background Side-Looking Cryostat
CFG-SV-LB	Low-Background Vertical Cryostat (Dipstick type).
CFG-SD-XLB	Extra-Low-Background Down-Looking Cryostat
CFG-SH-XLB	Extra-Low-Background Horizontal Cryostat (Dipstick type).
CFG-SJ-XLB	Extra-Low-Background J-type Cryostat
CFG-SL-XLB	Extra-Low-Background Side-Looking Cryostat
CFG-SV-XLB	Extra-Low-Background Vertical Cryostat (Dipstick type).

## GEM ICS-E Cryostat

- May only be purchased with a detector.
- Append matching Detector Endcap Size designation to Cooling Rod Length model: -70, -76, -83, -95, -108 [e.g., CFG-ICS-E, ICS-LL139-76 for GEM30-76-ICS-E].

Model	Description
CFG-ICS-E	Integrated Cryocooling System with External Preamp. <b>Cooling Rod Length must be specified, see below.</b>

**Cooling Rod Length. Add as separate line item ICS-LLExxx where xxx = one of the following lengths (mm): 025, 114, 139, 190\*, and append matching Detector Endcap Size [e.g., ICS-LLE190-70].**

\*Recommended cooling rod length (ICS-LLE): 139 mm for use with 4" lead shield. 190 mm for use with 6" lead shield. Other lengths available by special order.

# GEM Series Coaxial HPGe Detector Product Configuration Guide

## GEM Streamline Dewars

For Cryostat	Choose	Description
CFG-GG	DWR-1.2G	1.2-liter All-Orientation Dewar
	DWR-3.0G	3.0-liter All-Orientation Dewar
	DWR-5.0G	5.0-liter All-Orientation Dewar
	DWR-MOD-3L	3-liter Multi-Orientation Dewar
	DWR-MOD-7L	7-liter Multi-Orientation Dewar
	DWR-0.7-SHP-G	0.7-liter Shallow-Hole Probe Dewar
	DWR-S/F	Storage/Fill Dewar for DWR-XG
CFG-HJ, SJ, SL	DWR-7.5B	7.5-liter Side-Looking Dewar
	DWR-13B	13-liter Side-Looking Dewar
	DWR-30B	30-liter Side-Looking Dewar
	MOBIUS-B	Möbius Recycler Side-Looking Dewar
CFG-SD	DWR-7.5D	7.5-liter Down-Looking Dewar
	DWR-13D	13-liter Down-Looking Dewar
	DWR-30D	30-liter Down-Looking Dewar
CFG-SV, SH	DWR-30	30-liter Dewar. Includes collar for 1.5" diameter cryostat.
	DWR-30-OP	30-liter Offset-Port Dewar. Includes collar for 1.5" diameter cryostat.
	MOBIUS-ST	Möbius Recycler Dewar for purchase stand alone
	MOBIUS-ST-DET	Möbius Recycler Dewar for purchase in combination with Detector



# **GEM Series Coaxial HPGe Detector Product Configuration Guide**



# GEM Series Coaxial HPGe Detector Product Configuration Guide

## GEM Series Coaxial HPGe Detector Product Configuration Guide

# **ORTEC**

**AMETEK**

**[www.ortec-online.com](http://www.ortec-online.com)**

Tel. (865) 482-4411 [ortec.info@ametek.com](mailto:ortec.info@ametek.com)

801 South Illinois Avenue, Oak Ridge, TN 37830 U.S.A.

Visit Our Website For International Office Locations

## Harsh Environments (-HE)

### High-Reliability Gamma Spectroscopy in Harsh Environment Conditions

Germanium Detectors have historically been hyper-sensitive and hyper-fragile. . . until now.

- Corrosion resistant
- Impervious to moisture
- Unaffected by dust and grit
- No loss in sensitivity

#### Introduction

Increasingly, methods are being developed in a variety of fields in which the advantages of high resolution germanium gamma ray detectors produce great improvements to measurement quality. Increased desire for "real time" results and reduction in labor cost is driving the measurement "out of the lab and into the process." Examples may be found in homeland security, nuclear safeguards, and in both nuclear and non nuclear "in plant" industrial processes. Developments in the field of neutron

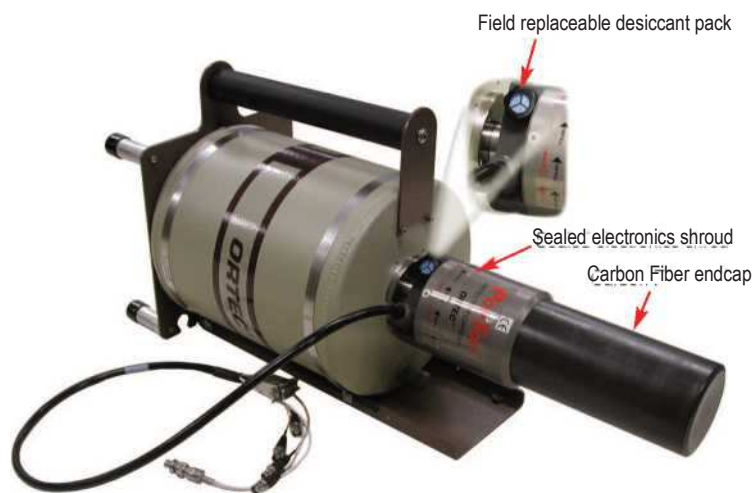

generators are creating a demand for portable and transportable assay systems based on neutron activation analysis techniques.

By exploiting the benefits of new materials and carefully re-engineering the electronics portion of the HPGe detector capsule, ORTEC has achieved a step up in HPGe detector reliability and robustness, surprisingly with no loss (actually often a gain!) in sensitivity to low energy gamma-rays.

#### The -HE Option

All ORTEC GEM, PROFILE, and GMX series HPGe detectors in PopTop capsules of 76 mm diameter or larger can be supplied in this format.

#### The -HE Option Features

- Rugged carbon fiber detector capsule endcap, corrosion resistant but with high transmission of low energy gamma-rays.
- Sealed electronics housing featuring an innovative, replaceable desiccant pack which ensures that the electronics stay 100% dry and indicates when it needs to be replaced.

#### Ordering Information

# ORTEC®

The -HE option is available for all GEM, PROFILE and GMX series HPGe detectors in PopTop capsules of 76 mm diameter or larger.

To order, append "-HE" to the detector model number.

# AMETEK

Example: GEM30P4-76-HE.

For an additional desiccant pack, order part number 806410.

Specifications subject to change.  
080817

[www.ortec-online.com](http://www.ortec-online.com)

Tel. (865) 482-4411 • Fax (865) 483-0396 • [ortec.info@ametek.com](mailto:ortec.info@ametek.com)  
801 South Illinois Ave., Oak Ridge, TN 37830 U.S.A.  
For International Office Locations, Visit Our Website

# ORTEC

## MAESTRO<sup>®</sup> 7

Multichannel Analyzer (MCA) Application Software



**AMETEK**  
ADVANCED MEASUREMENT TECHNOLOGY

## Advanced Features

- Windows 7 (32-bit and 64-bit) and Windows XP (32-bit) compatible.
- ORTEC CONNECTIONS 32- and 64-bit network connectivity: local and remote control for all supported instruments via a common GUI.
- Intuitive User Interface consistent with other ORTEC application software such as GammaVision and ScintiVision.
- Advanced “smart” analysis functions: Fast Peak Search, Region of Interest (ROI), Peak Fit, and Overlay Spectrum Comparison.
- Password protected functions.
- Multiple Detector Interface (MDI): choose to view up to eight “live” and eight stored spectra simultaneously on a single PC.
- Automated “Jobs” for consistent and reliable data acquisition and reporting.
  - NEW “List Mode,” time-tagged data event gathering; create time-sliced spectra of any period during data acquisition.

## Real Benefits

- Integration with the most popular PC platform in the world maximizes compatibility, productivity, and cost-effectiveness.
- Low Total Cost of Ownership with hardware/software compatibility and remote control operations.
- Rapid implementation with minimal training.
- Robust data evaluation for accurate and reliable results.
- Eliminate unauthorized changes to system parameters and loss of acquiring data.
- Efficiency improved through instant access to detector status and spectrum data.
- Maximize productivity with consistent processes and data integrity.
- Ability to select acquisition of “period of interest” enhances detection sensitivity.

MAESTRO is a multichannel analyzer (MCA) “emulation” software package. When used in conjunction with a personal computer, and appropriate MCB hardware, MAESTRO constitutes an advanced “smart” multichannel analysis environment for use in a wide variety of scientific applications in industry, teaching, and research, including nuclear counting laboratories.

The MAESTRO user interface provides live spectral display and control of hardware and provides a number of “smart” analysis tools. The spectrum display and manipulation has a common “look and feel” with other ORTEC spectroscopy products, such as GammaVision and Scintivision.

Full control of acquisition and all MCB hardware features is provided. The software auto-detects the attached hardware, presenting the user with only those features specifically available for that hardware. For example, members of the ORTEC DSPEC series of digital HPGe gamma spectrometer systems provide full control of the digital filter, auto-PZ and Insight® oscilloscope mode. These features are displayed by the MAESTRO software when the DSPEC hardware is connected to the system.

As a member of the ORTEC CONNECTIONS suite of software products, MAESTRO has the capability to fully support up to 250 detector systems across a local area network; a remote detector appearing to a local operator is no different to one physically attached to the local PC workstation.

For over two decades, MAESTRO has set the standard for Windows-based MCA Emulation. MAESTRO Version 7.0 advances further, adding the following new features:

# MAESTRO®

- **New!** Windows 7 64-Bit Compatibility with CONNECTIONS Version 8
- **New!** List Mode Data Acquisition for Time Correlated Spectrum Events
- **New!** Improved Peak fit calculations
- **New!** Improved graphics handling for multiple displays
- **New!** Open spectrum files directly from Windows Explorer
- **New!** Improved performance with Job Functions and display updates

It's really no surprise that MAESTRO continues to be the worlds most popular nuclear MCA software!



## Display and User-Interface Features

MAESTRO provides an intuitive user interface to simplify hardware control and both routine and advanced measurement processes. The most commonly used functions are implemented as "hot keys" or toolbar buttons for rapid access.

The spectrum window is often the primary user focus when using MAESTRO and up to eight live detectors and eight saved spectra can be displayed concurrently. Full and expanded views of each spectrum are shown simultaneously. The spectrum expanded view can be zoomed in to examine a specific peak or energy region. Both windows display any marked Regions of Interest (ROIs), and the zoomed region is easily repositioned by simply clicking the new position in the full spectrum display.

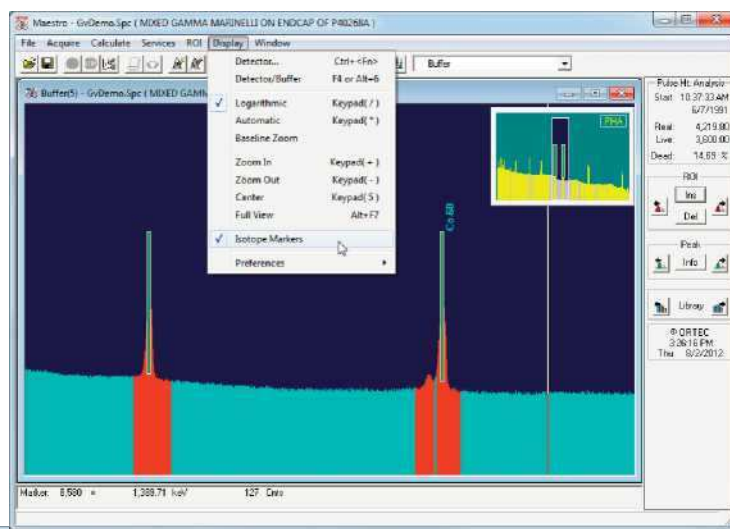

When viewing a live detector, the spectrum view is updated in real time and provides current spectral data, live peak calculations, and hardware properties — even for remote instruments connected to different computers on the network. Viewing spectrum peaks, library energies, or regions of interest is simple with the convenient side panel buttons.

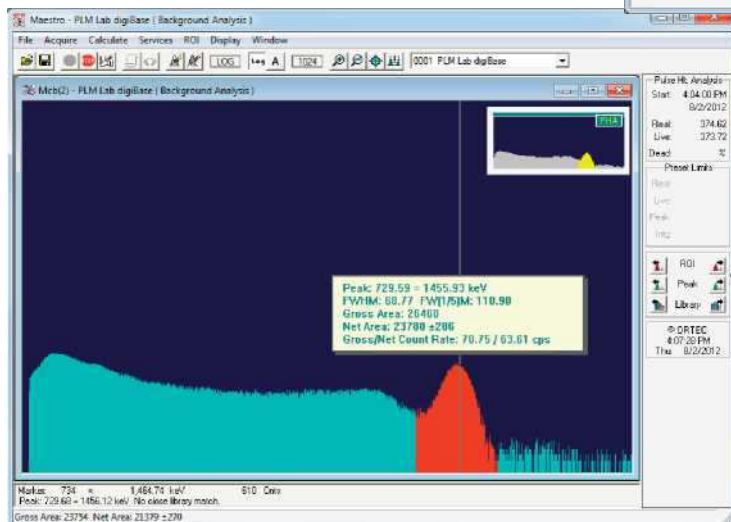

RO  
|  
Peak  
Library ^

Working with individual Regions of Interest (ROIs) or calculating peak areas is easily accomplished with either the advance peak search or "rubber rectangle" features. As many regions as desired may be marked, and these may be saved to an "ROI" file that can be recalled and applied later to a different spectrum.

MAESTRO permits a wide choice of display options. Choose from a variety of color schemes, and display the spectrum as dots or filled bars. These settings can be used to create the optimal view for various lighting conditions or simply to suit your preference.

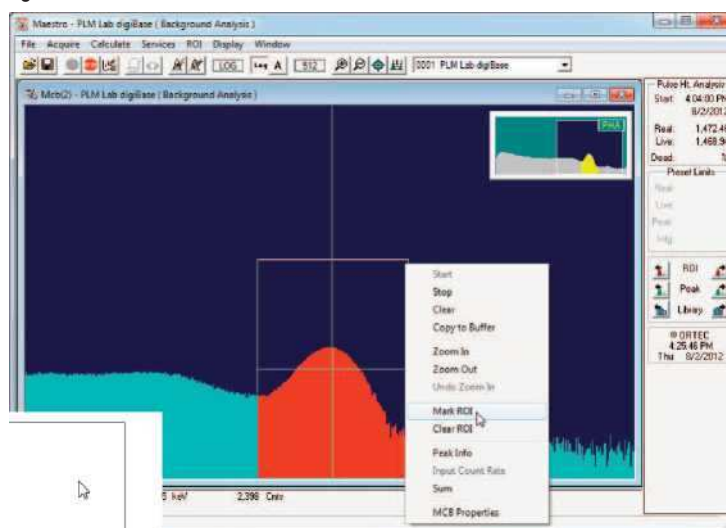

**Advanced Features**

Aside from the basic MCA Emulation functions, MAESTRO has advanced features to rapidly assess spectrum data such as:

- Multipoint Energy and Peak Shape Calibration for accurate peak calculations.
- Fast Mariscotti Peak Search to instantly mark Regions of Interest based on user-defined sensitivity settings.
- Nuclide Identification from libraries tailored to the application. Isotope markers show the location of library energies with amplitude estimation at each peak to confirm identification.
- Peak Calculations including centroid, shape, gross and net area with uncertainty, and semi-quantitative nuclide activity based on peak abundance

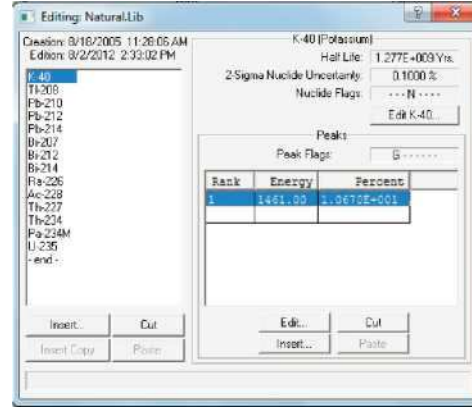

- corrections.
  - **New!** Choice of number of channels averaged to determine background.
  - **New!** Improved FWHM accuracy when peak centroid falls between two channels.

- Region of Interest (ROI) reports consisting of all Peak Calculation parameters for each marked region.
- Interactive "Jump to Peak" using ROI marker, Library, or Peak Search options.
- Spectrum overlay for direct visual comparison of sample results to a reference.
- Spectrum Stripping to clearly reveal differences or remove background.
- Spectrum Smoothing to improve statistically poor peak shape.

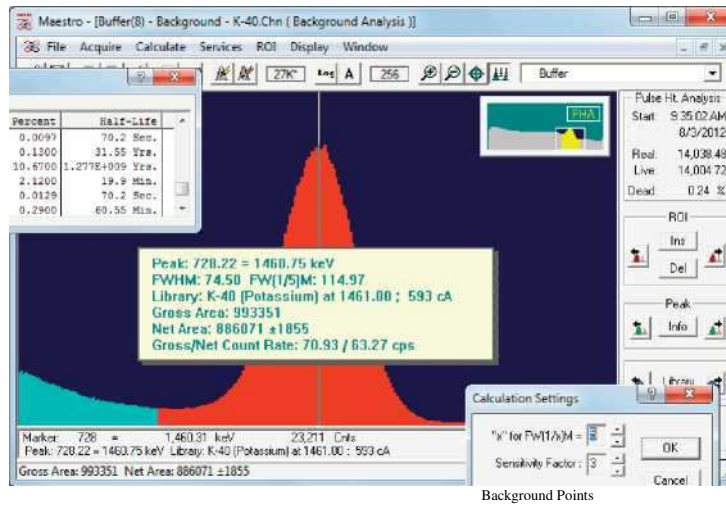

# MAESTRO®

These features are available with saved spectra or when operating on a detector. When data collection is in progress peak calculations shown in the "Peak Info" window are updated in real time for immediate results.

## Automation with Jobs

Although interfacing with MAESTRO from the toolbar and menus is simple and intuitive, this method of operation does not guarantee consistent processing that is often needed for measurements performed frequently or by different individuals. In these circumstances a more structured approach may be preferred, and simple text scripts called "Jobs" provide this capability in MAESTRO. The command set includes the most common operations, and has been expanded in Version 7 to include List Mode functions, closing MCB or Buffer windows, and enhancements to the "WAIT" command to improve efficiency. Custom processes can also be implemented with the "RUN" command which launches any external application.

Job Files may be run automatically when MAESTRO starts by including the path to the Job file as a command line argument in Windows shortcuts. This approach is frequently used to establish consistent processes from a common initiation point, and provides a simple method to run multiple Jobs in separate instances of MAESTRO.

```
!Close any existing windows.
CLOSEMCBS
CLOSEBUFFERS

!Set Detector and activate List Mode.
SET_DETECTOR 1 SET_LIST
!set presets and Acquire List Data.

SET_PRESET_C LEAR
SET_PRESET_Real 1000
CLEAR
START
WAIT
SAVE "MyListData.Lis"
!Load List File, Filter data to a specific date range, and
save to 'spc' spectrum format.
CLOSEMCBS
RECALL "MyListData.LIS"
SET_RANGE "6/29/2012", "14:05:00", 900 SAVE
"MyListDataRange.spc"

!Loop through List Data and generate 'rci' reports for
spectra generated from '100 second time intervals.

CLOSEBUFFERS
RECALL "MyListData.LIS"
Loop 10
  SET_RANGE "S(LOOP)00", "100"
  DESCRIBE SAMPLE Measurement #5(Loop)
  RECALL ROI "DECAYPK.ROI"
  REPORT "PRN"
End_Loop

!set the detector back to PHA Mode.
SET_DETECTOR 1
SET_PHA
```

## Hardware Control

With the release of CONNECTIONS Version 8, 64-bit Windows 7 compatibility is available for all instruments that use USB<sup>3</sup> and TCP/IP connectivity. This update also retains compatibility for instruments that were previously supported in 32-bit Windows XP and/or Windows 7<sup>4</sup>. Instruments that are dependent on a host computer, such as plug-cards or USB devices, can be shared on a network through the MCB Servers running on each computer. This process allows 64-bit Windows 7 computers to operate instruments that are not 64-bit compatible through their 32-bit host computers.

The interface between hardware and software is provided through the ORTEC CONNECTIONS framework. This application layer encompasses all of the hardware drivers and communication protocols that are necessary for software applications to control the MCB (Multichannel Buffer) instruments. The hardware controls are accessed through MCB Property pages that are integrated with MAESTRO and other standard ORTEC applications.

The MCB Properties pages are tailored to the specific instrument such that only the applicable features are presented to the user. Common features for various instruments include:

- Detector HV bias control
- Course and Fine Gain Adjustment
- Zero and Gain Stabilizer
- SMART-1 Detector functions
- ZTD loss-free counting correction
- Analog and Digital Amplifier Filters
- Automatic and Manual Optimization
- Sample changer control
- ID results for Detective instruments
- Insight® Oscilloscope mode
- Battery Voltage monitoring for portable instruments.
- Acquisition Presents including Real and Live Time, ROI Peak, ROI Integral, Peak Uncertainty, or MDA

Further details for hardware functions are provided in the relevant product literature.

### “List” Mode Spectrum Acquisition

The most commonly used acquisition mode in nuclear spectroscopy is pulse height analysis or PHA mode. In this mode a spectrum is gathered for a period, usually known as the acquisition time, of the incoming pulse-height data, event by event. These data are stored in a histogram versus pulse height (usually proportional to energy). The

spectrum is the histogram of all events in the acquisition period.

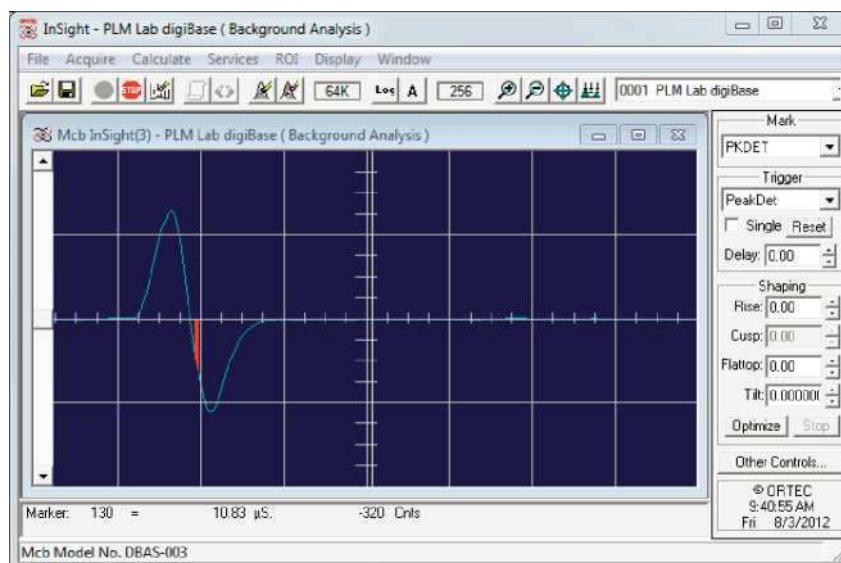
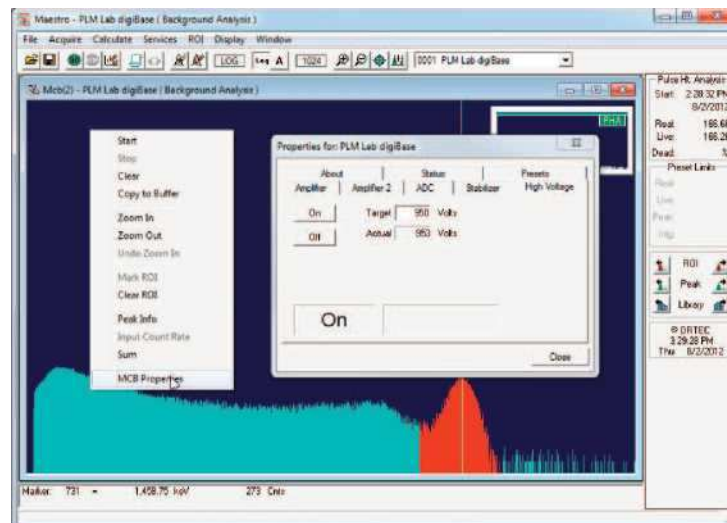

<sup>3</sup> Excludes the microBase which has been obsolete for several years.

<sup>4</sup> Instruments using the IPX/SPX protocol require Windows XP. This may be accomplished on a Windows 7 computer using the XP Mode Virtual Machine. Instruments that have a Dual-Port Memory option can take advantage of the DPM-USB to communicate over a USB connection in the Windows 7 or XP environments.

# MAESTRO®

List mode acquisition adds another dimension to PHA mode. During the acquisition every event is “time tagged,” that is to say its time of occurrence is recorded along with its pulse height. After the acquisition is completed, the data may be sorted and spectra constructed to represent the measurement situation during some period of interest, for example, when the detection system was experiencing a transient of high activity.

List mode data acquisition has been available in certain ORTEC instruments, such as the digiBASE, digiBASE-E, DSPEC Pro, and more recently the DSPEC-50/502 for some time, but was only accessible through custom applications using the CONNECTIONS Programmer’s Toolkit. With the release of MAESTRO Version 7 this functionality is now accessible in a standard application!

In MAESTRO Version 7, post-acquisition evaluation of list mode data is simplicity itself! When loaded into a buffer window, the collection start and stop time range can be varied to instantly create a complete spectrum that represents that selected time period. This process allows the “period of interest” to be selected directly, or the software can scan through the entire collection period with a user-defined window. Identifying transient activity periods is as easy as that!

When a particular time period of interest has been defined, this data set may be saved to a new List Mode file consisting of this subset of data, or to any of the traditional ORTEC spectrum formats that are compatible with all standard ORTEC applications. These formats include:

- **CHN** A compact binary format that contains the basic MCA emulation data — such as detector and sample description, energy calibration, acquisition information, and the spectrum.
- **SPC** A compact binary format that contains more advanced parameters used by products such as GammaVision.
- **SPE** A simple ASCII text format contains data similar to the CHN files.

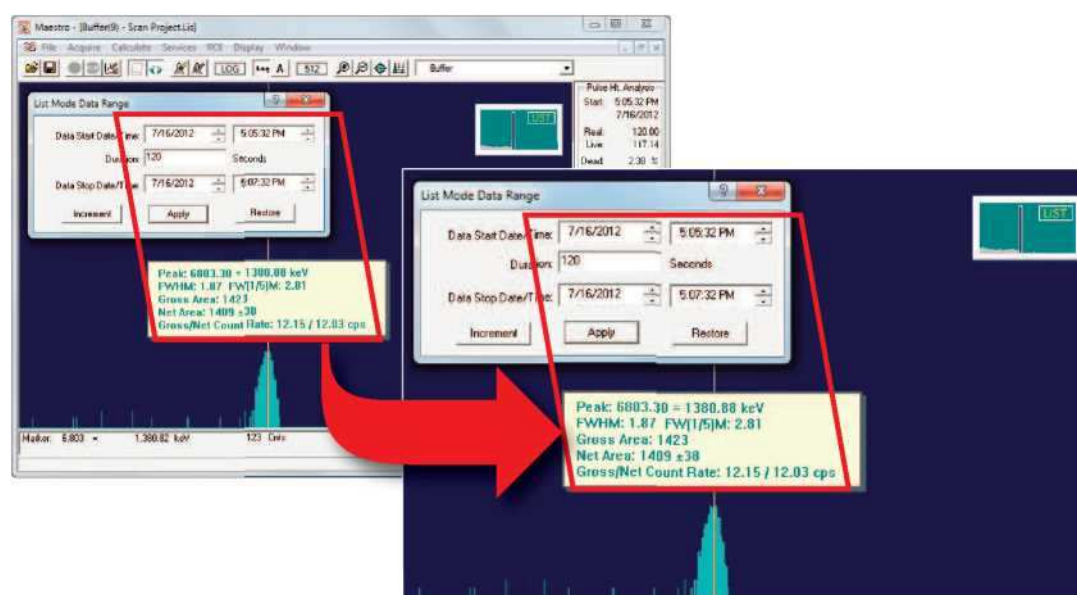

# MAESTRO®

## Ordering Information

Model	Description
A65-BW	MAESTRO Multichannel Analyzer (MCA) Application Software. Includes standalone or first network copy binary use license.
A65-GW	Hard Copy Documentation for MAESTRO. Note: A PDF version of the MAESTRO manual is installed with the application. Hard copy documentation must be ordered separately if desired.
A65-NW	Single Use Network Copy. Requires current version of A65-BW.
A65-UW	MAESTRO update from A65-BW or A65-B32 models.
A65-VW	MAESTRO V&V Test Results and Certificate of Validation.
A65-2YW	2 Year Software Subscription for A65-UW.
A65-3YW	3 Year Software Subscription for A65-UW.
A65-4YW	4 Year Software Subscription for A65-UW.
A65-5YW	5 Year Software Subscription for A65-UW.

## Options

A11-B32	CONNECTIONS Programmer's Toolkit with ActiveX™ Controls.
A12-B32	Analysis Results File (UFO) Toolkit.
A49-B32	DataMaster Spectrum File Conversion Software.
C53-B32	NuclideNavigator III Master Library.

Note: Software Subscriptions provide automatic updates when new versions of MAESTRO become available. These options are available to users holding a Binary Use License (BUL) for the current version of MAESTRO (A65-BW).

*f\* n^Cf\*®*  
*I EU*

[www.ortec-online.com](http://www.ortec-online.com)

Tel. (865) 4824411 • Fax (865) 483\_0396 • [ortec.info@ametek.com](mailto:ortec.info@ametek.com)  
801 South Illinois Ave., Oak Ridge, TN 37830 U.S.A.  
For International Office Locations, Visit Our Website

Specifications subject to  
change 060617

4 |U|E|E|F'

"Y



# L140AD-4

14-inch Ultra Rugged Laptop with Intel® Core™ i5-1235U



Tablet mode

Laptop Mode

## KEY FEATURES

- 12th Gen. Intel® Processor Family – Alder Lake Processor
- 14" 1920 x 1080 FHD LED panel with direct optical bonding
- Antiglare technology for sunlight readability
- Dual battery with hotswappable design for wholeday work
- Flip design for quick switching between rugged laptop and rugged tablet modes
- Magnesium alloy enclosure with double injection for drop protection
- Integrated smart card reader or 2nd GigaLAN port

## INTRODUCTION

The Winmate L140 Series Rugged Laptop delivers exceptional performance, durability, and versatility for demanding environments. Powered by the Intel® Alder Lake processors, it features a sunlight-readable FHD display with direct optical bonding and anti-glare technology. Designed with a magnesium alloy enclosure and dual hot-swappable batteries, it ensures all-day reliability. The flip design offers quick switching between laptop and tablet modes, making it ideal for field operations, industrial tasks, and mission-critical applications. Winmate has established itself as the number one supplier in the rugged laptop and rugged tablet market, driving advancements in rugged computing technology.

## SPECIFICATIONS

Display			
<b>Bonding</b>	Optical Bonding for Sunlight Viewability	<b>Resolution</b>	1920x1080
<b>Size</b>	14.0 inches	<b>Contrast Ratio</b>	800:1
<b>Panel Brightness</b>	700.0 nits	<b>View Angles</b>	85,85,85,85
<b>Type</b>	Projected Capacitive Multi Touch		
System Specification			
<b>Processor</b>	Intel Core i5-1235U (up to 4.4GHz)	<b>Memory</b>	8GB DDR5 SDRAM 16GB DDR5 SDRAM (Optional) 32GB DDR5 SDRAM (Optional)
<b>Storage</b>	256GB M.2 NVMe SSD 512GB M.2 NVMe SSD (Optional) 1TB M.2 NVMe SSD (Optional) 2TB M.2 NVMe SSD (Optional) 2nd storage available with up to 2TB M.2 NVMe SSD (Optional)	<b>Security</b>	Trusted Platform Module (TPM) 2.0 Kensington Lock
<b>Operating System</b>	Windows 11 IoT Enterprise LTSC (64 bit) Windows 10 IoT Enterprise LTSC (64 bit) (Optional)	<b>WLAN</b>	Support
<b>BT</b>	Support	<b>WWAN</b>	4G LTE (Optional) 5G (Optional)
<b>GNSS</b>	GPS, GLONASS	<b>RFID</b>	HF RFID reader 13.56 MHz (Optional)
<b>Smart Card Reader</b>	Smart Card Reader (Mutually exclusive with 2nd LAN)	<b>Fingerprint Scanner</b>	Fingerprint scanner (Optional)
Camera			
<b>Front Camera</b>	2MP front camera	<b>Rear Camera</b>	8MP rear camera with autofocus and LED light (Optional)

**WirJIMATE**  
 No. 18, Zhongxing S. St., Sanchong Dist., New Taipei City 241017, Taiwan (R.O.C.)  
 Tel: +886-2-8511-0288  
 Website: www.winmate.com

**Mechanical**

<b>Dimension</b>	340 x 230 x 38 mm	<b>Weight</b>	2.65 kg
<b>Cooling System</b>	Fan Design		

**IO Ports**

<b>USB Port</b>	1 x USB 3.0 (Type C) 3 x USB 3.0 (Type A) (One USB-A is mutually exclusive with 2nd LAN)	<b>Serial Port</b>	1 x DB9 (RS232 / RS422 / RS485, switchable with optional software)
<b>SD Card Slot</b>	1 x Micro SDXC Slot	<b>SIM Card Slot</b>	1 x Nano SIM card slot
<b>Video</b>	1 x HDMI 4K Output (Optional)	<b>Audio</b>	1 x Audio combo 3.5mm audio combo jack Dual Digital Mic With Noise Cancellation Dual Speaker
<b>LAN</b>	1 x RJ45-10/100/1000 GigaLAN port 2nd LAN (Mutually exclusive with one USB-A & Smart Card Reader) (Optional)	<b>Indicator</b>	4x LED Indicator for Power, Battery, HDD, RF status

**Environment**

<b>Operating Humidity</b>	10% to 90% RH, non-condensing	<b>Operating Temperature</b>	-20°C to 60°C
<b>Storage Temperature</b>	-30°C to 70°C	<b>Shock</b>	USA: MILSTD810H Method 516.8 Procedure I NATO: STANAG 4370/AECTP400 Edition 3 Method AECTP 402-Procedure I
<b>Vibration</b>	USA: MILSTD810H Method 514.8 Procedure I NATO: STANAG 4370/AECTP400 Edition 3 Method AECTP 401-Procedure I	<b>IP rating</b>	IP65
<b>Drop</b>	USA: MIL-STD-810H Method 516.8, 4 ft NATO: STANAG 4370/AECTP400 Edition 3 Method AECTP 404 – Procedure II, 4 ft	<b>EMC</b>	USA: MIL-STD-461G CE101, CE102, RE101, RE102, CS118 MIL-STD-461G CS101, CS114, CS115, CS116, RS101, RS103 (Optional) MIL-STD-461G RE102 Ground Army Grade  NATO: STANAG 4370/AECTP501 NCE01, NCE02, NRE01, NRE02, NCS12 (Optional) STANAG 4370/AECTP501 NCS01, NCS07, NCS08, NCS09, NRS01, NRS02 (Optional) STANAG 4370/AECTP501 NRE02-2 Land Environment (Optional)
<b>TEMPEST</b>	USA: NSA NSTISSAM TEMPEST/192 (Optional) NATO: SDIP27 (Optional)		

**Certification**

<b>Certification</b>	CE, FCC
----------------------	---------

**Security Function**

<b>SOTI MobiControl</b>	SOTI MobiControl Compliance	<b>Kensington Lock</b>	Kensington Lock Support
-------------------------	-----------------------------	------------------------	-------------------------

**Control**

<b>Button</b>	1 x Power, 2 x volume key, 2 x Programmable Function Keys QWERTY keyboard with RGB backlight
---------------	---

**Power**

<b>Battery</b>	Hot-swappable 2 x 11.55V, typ. 3220 mAh Li-Ion Battery (3S1P)	<b>Battery Operating Time</b>	Standard Battery: 11 hours
<b>Power Rating</b>	19V DC	<b>Adapter</b>	100-240V, 50-60Hz / 19V DC

**Accessory**

<b>Accessory</b>	Adapter and Power Cord Standard Battery	<b>Optional Accessory</b>	Spare Battery (Optional) Battery Charger (Optional) Vehicle Charger (Optional) Carry Bag (Optional)
------------------	---	---------------------------	---

DIMENSIONS UNIT:MM

**NOTE**

/ Disclaimer /



No. 18, Zhongxing S. St., Sanchong Dist., New Taipei City 241017, Taiwan (R.O.C.)  
Tel: +886-2-8511-0288  
Website: www.winmate.com

Revised:V.250816.250806

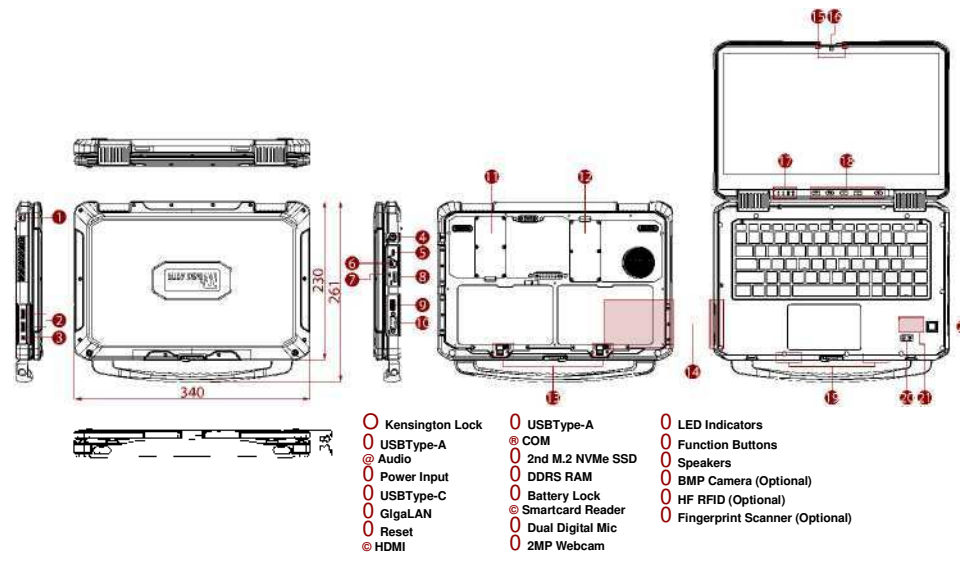

1. Accessories and Integrated Options may vary depending on your configuration.
2. Total usable memory and storage will be less dependent upon actual system configuration.
3. The actual transfer speed will vary depending on many factors including the processing speed of the host device, file attributes, and other factors related to the system configuration and your operating environment.
4. The USB TypeC connector follows USB 3.0 standard, which does not support Alternate Mode (ALT) or USB Power Delivery (USBPD).
5. The battery life is measured at dimming LCD brightness. Varies depending on the usage conditions, or when an external device is attached.
6. The 2D drawing is simplified drawing and some components are not marked in detail.
7. Length measurements do not include protrusions. Weight varies with options.
8. TPM 2.0 available upon request.
9. SOTI is available upon request.
10. The product shown in this datasheet is a standard model. For diagrams that contain customized or optional I/O, please contact the Winmate Sales Team for more information.



No. 18, Zhongxing S. St., Sanchong Dist., New Taipei City 241017, Taiwan (R.O.C.)  
Tel: +886-2-8511-0288  
Website: www.winmate.com

Revised: V.250816.250806

# NuDET ENA

WIDE RANGE OF SODIUM IODIDE,  
LBC, CeBr<sub>3</sub> SCINTILLATOR PROBES



The NuDET ENA premium series of spectrometric gamma probes are designed for a wide range of applications including industry, early warning networks, environmental monitoring and nuclear site monitoring. The probes are capable of working in environments with ambient dose equivalent rates from 10 nSv/h to 40 µSv/h (2" NaI:Tl crystal), 10 nSv/h to 20 µSv/h (3" NaI:Tl crystal), from 10 nSv/h to 60 µSv/h (1.5" CeBr<sub>3</sub>, 1.5" LBC). The probes can be connected directly to PC via USB cable or the Ethernet.

## Benefits

- Integrated MCB3 multichannel analyzer
- Different types of crystals – NaI(Tl), LBC, CeBr<sub>3</sub>
- Measurement of ambient dose equivalent rate
- Automatic recovery after power supply outage
- Spectrum stabilization
- Direct connection to PC via USB or ethernet

## Key figures

**40 keV - 3 MeV**

<sup>^</sup> Energy range

**10 nSv/h - 40 µSv/h**

<sup>^</sup> Maximum H\*(10) range for 2" NaI probe g

**IP67**

<sup>^</sup> Ingress protection

z

## Product Description

- NuDET NAI SBG.D.2.2.2 or NuDET NAI SBG. D3.3.3 2" or 3" NaI(Tl) scintillation crystal with PMT, LBC 1.5" or CeBr<sub>3</sub> 1.5" or 2"
- NuNA MCB3 multi channel analyzer
- Auxiliary electronic components (connectors, power regulators etc.)
- Aluminum housing
- Optional meteorological station, and GPS

module for cabinet

## Control Software

- MS Windows 10, 11 compatible
- Measurement of ambient dose rate equivalent rate
- Calculation of abundance of radionuclides in the spectrum
- Periodic storage of measured spectra
- Displaying current spectrum
- User customizable nuclide library
- Potential to display data from other sources, e. g. meteorological data, temperature sensor, GPS mapping

## Product Application

- Industrial applications
- Environmental monitoring
- Workplace monitoring

## Product Specifications

Power supply	12 + 24 VDC ±25%
Consumption	<3W
Interfaces	RS-485, USB or RJ45 LAN (Ethernet)
Dimensions	Height 443 mm, diameter 110 mm
Temperature range	from -30to+55°C
Ingress protection	IP67
Detector resolution	< 68% (2" NaI probe) < 7.8% (3" NaI probe) < 3.1 % (1.5" IBC probe) < 4.1 % (15" CeBr probe)
Maximum usable H*(10) range	10 nSv/h - 40 pSv/h (2" NaI) 10 nSv/h - 20 pSv/h (3" NaI) 10 nSv/h - 60 pSv/h (CeBr <sub>3</sub> , LBC)



Detector stabilization	By gam shift controlled by position of 1460 keV line of K-40
Energy range	40 keV - 3 MeV
Conversion gain	256, 512, 1024, 2048 or 4096 channels
Coarse gain	x1, x2
Fine gain	from 08 to 20
Dead time correction	Gedcke-Hale live-time clock method, < 5% error up to 50 000 CPS input count rate
HV power supply	from 0 to +1100 V DC in step of 1V (software adjustable)
Shaper	Trapezoidal shaper Rise time 0.5 to 6 ps Flat top 0.5 to 2 ps
Time pre-set	Live time, real time: 0 to 2", in step of 100 ms

# NuDET PLASTIC

## Plastic Scintillation Detectors



PLASTIC is a range of plastic scintillation detectors.

Plastic scintillators are solid solutions of luminophores in polymer characterised by a short decay time and a resistance against high dose rates. They are widely used in detection systems for their efficiency, high reliability and variety of shapes and sizes.

### Benefits

- Suitable for fast-timing measurement
- Numerous possibilities of application
- Variety of geometric shapes and sizes, customisation possible
- Processing of raw materials inhouse
- Control of the entire production process: styrene polymerisation and material homogeneity, high quality-consistency

### Key figures

**56%** \* Light output  
(relative to anthracene)

**2.5n** ^ Decay constant

**$\frac{S}{3}$  1.03g/cm<sup>3</sup>** \* Density

## Product description

Plastic scintillators have an extremely wide field of application.

Used in thin layers, they detect protons, electrons and beta particles with a low background. Standard thickness of the foil is 0.3 mm and 0.5 mm.

Large volume plastic scintillators are suitable for measuring gamma radiation. They are widely used in the detection systems due to their high efficiency, high reliability and the variety of shapes and sizes that may be produced.

Green-emitting plastic scintillators are plastic scintillators with a longer emission wavelength

and similar light output and properties to standard blue-emitting scintillators. They are designed to be used with photosensors such as photodiodes, the sensitivity of which is higher at longer wavelengths.

Block, cylinder and foil scintillators of various sizes may be produced on request without housing, with or without a polished surface, fixed to the light-guide or as plastic detection assemblies coupled with a photomultiplier.

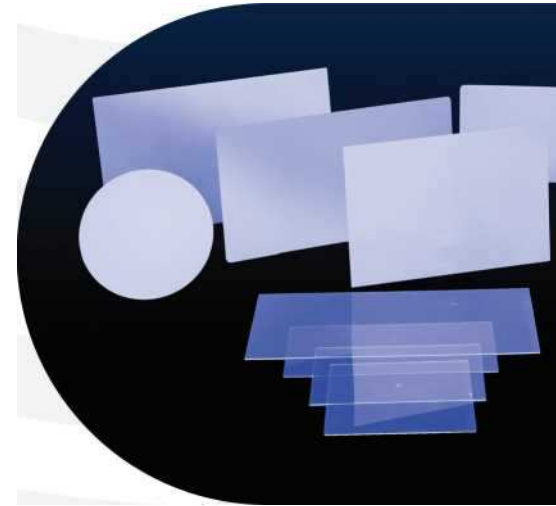

## Product applications

- Detection of beta, gamma radiation, and neutrons
- Detection of ionising radiation in high energy physics
- Homeland security (gate monitoring systems for airports, NPPs, scrapyards, etc.)

## Examples of Standard Products (for both blue and green-emitting scintillators)

Dimensions	PMT Assembly	Interface/Socket
90 mm (diam.) x 120 mm (height)	2"	PMT pins (14-inch plug)
800 x 300 x 50 mm	2"	PMT pins (14-inch plug)
	Standard Blue-Emitting Scintillators (SP32)	Green-Emitting Scintillators (SP33)
200 mm base 100 mm	polystyrene type, 1 1/8" integrated	polystyrene installed cable,
Density	1.03 g/cm <sup>3</sup>	1.03 g/cm <sup>3</sup>
Refractive index	1.57	connector interface (BNC,
Softening point	70 - 75°C	70 - 75°C
Light output (relative to anthracene)	56%	integrated voltage divider 55%
Decay time	2.5 ns	4.4 ns
Wavelength of maximum emission	425 nm	503 nm

# NuDET EGM.G2

WIDE RANGE  
INTELLIGENT PROBE  
WITH GM COUNTER



The NuDET EGM.G2 premium series of wide range gamma probes based on GM detectors for a variety of indoor and outdoor applications around dose rate measurement.

The EGM series is designed to work in ambient dose equivalent rate environments from 10 nSv/h to 10 Sv/h. It communicates through Ethernet, USB, RS232 or RS-485, and supports MODBUS and NUVIA communication protocols.

## Benefits

- High measurement accuracy
- Modular system allowing up to three GM tubes for wide measurement range
- Ability to detect a wide range of dose rates
- Rugged construction, airtight housing and waterproof connectors
- Open and easy-to-use data transfer protocol
- MODBUS support
- Automated and optimized switching between detector tubes

## Key Figures

# P67

- Ingress Protection

IP67

- Compliant with IEC 61017

- Linearity and energy dependence

## Product Description

The new range of intelligent probes with GM tube is in a uniform design. The output interface is given by an interchangeable module. Data storage is possible in the built-in memory.

The NuDET EGM.G2 probes are able to operate over a wide variety of measurement ranges and designed for ambient radiation monitoring for radiation sources in the environment or monitoring for radiation safety in the workplace and providing real-time measurement. Being both resistant to harsh environments and a waterproof housing the NuDET EGM can safely and accurately measure in any environmental and radiological conditions.

These highly sensitive probes are used for H\*(10) ambient equivalent dose rate measurements over a dynamic range of up to 9 decades. All the probes utilize energy compensated Geiger-Muller tubes and an integrated, microprocessor-based system for calculating, storing and transmitting the measurement and system data. The use of the large volume low dose rate detectors allows detection of minor changes in dose rate even at low background with fast response.

The second or even third detector is for the measurement of high dose rates. Each probe is calibrated to the reference source (Cs-137), and therefore has a high level of accuracy over its full scale. The probe always has one of the following communication interfaces available: USB, RS485/RS232, isolated RS485, Ethernet. The interface can be exchanged by the user for another type. The probes provide measured values in counts per second or pSv/h. This product range is type approved according to the CSN EN 60532:2010.



## Product Specifications

<b>Energy range H*(10)</b>	Compliant with IEC 61017 from 80keV to 1.5MeV
<b>Temperature range</b>	from -30 to +55°C
<b>Relative humidity</b>	up to 80 % RH (noncondensing)
<b>Power supply</b>	12 - 48 VDC ± 25% or PoE 802.3af, less than 0.6 W (with the Ethernet interface less than 1 W)
<b>Interfaces</b>	USB internal (available in all versions), USB external, RS485/RS232 (SW switchable), isolated RS485, Ethernet
<b>Connector</b>	WEIPU*SF1213/P9
<b>Models available</b>	EGM-01.G2 EGM-02.G2 EGM-03.G2 EGM-04.G2 EGM-05.G2 EGM-06.G2 EGM-07.G2 EGM-08.G2 EGM-0104.G2
(See characteristics in the table below)	

## Options & Accessories

Data Logger

Standalone data logger with embedded control SingleBoard Computer, power supply (options include: mains supply, battery or solar supply) and data transmission system (GSM, GPRS (UMTS), radio, satellite or TCP/IP).

Central software — environmental RMS

NuSOFT RADIS - Radiation monitoring control and information management system for data acquisition, evaluation and presentation. Server based system that remotely monitors and controls the status, operation, data transmission, data storage, data handling, data analysis and display for all radiation monitoring systems within the Environmental Radiation Monitoring Network.

Central software — workplace RMS

NuSOFT DORMIS - Information system for workplace radiation monitoring network (area, technology and personal monitors, personal dosimetry and access control). The software DORMIS is designed for data acquisition from various radiation monitoring devices. It contains modules for the diagnosis, management, processing and presentation of the measured data, modules for output data creation and data archiving. DORMIS contains two main modules - Personal Dosimetry (access management and registration of accumulated dose) and Workplace Radiation Monitoring (indoor RMS data acquisition and registration).

Customization

Special configuration (measuring range, sensitivity), dimensions, colours, materials and parameters (special connector or pre-installed wire cable with open ends) are available on request.

## Product Applications

- Environmental monitoring
- Workplace monitoring
- Radiation security monitoring at borders, airports, railways, transportation

## Options & Accessories

Series	EGM-01.G2	EGM-02.G2	EGM-03.G2
<b>Detector type</b>	LND*71210	LND*71210(LD) LND*7149(HD)	LND* 7807(LD) LND* 7149(HD)
<b>Measuring range H*(10)</b>	50 nSv/h - 20mSv/h	50 nSv/h - 20 mSv/h (LD) 1 pSv/h - 2 Sv/h(HD)	10 nSv/h - 15 pSv/h(LD) 1 pSv/h - 2 Sv/h (HD) '1
<b>Dimensions(0x 1)</b>	69/60 x 285 mm	69/60 x 285 mm	69/60 x 580mm
<b>Weight</b>	0.71 kg	0.72 kg	1.16 kg
<b>Sensitivity (Cs-137)</b>	1.4 CPS per 1 pSv/h	1.4 CPS per 1 pSv/h (LD) 0.15 CPS per 1 pSv/h(HD)	16 CPS per 1 pSv/h (LD) 0.15 CPS per 1 pSv/h (HD)

Series	EGM-04.G2	EGM-05.G2	EGM-06.G2
<b>Detector type</b>	LND*7807(LD) LND*71632(HD)	LND* 71210 (LD) LND*71632(HD)	LND*7149
<b>Measuring range H*(10)</b>	10 nSv/h -1.5 pSv/h(LD) 1 pSv/h -10 Sv/h (HD)	50 nSv/h - 20mSv/h(LD) 1 pSv/h -10 Sv/h (HD)	1 pSv/h - 2 Sv/h(HD)
<b>Dimensions(0x 1)</b>	6 9/6 0 x 580 mm	6 9/6 0 x 285 mm	6 9/6 0 x 285 mm
<b>Weight</b>	1.16 kg	0.72 kg	0.68 kg
<b>Sensitivity (Cs-137)</b>	16 CPS per 1 pSv/h (LD) 0.026CPS per 1 pSv/h (HD)	1.4 CPS per 1 pSv/h(LD) 0.026CPS per 1 pSv/h (HD)	0.15 CPS per 1 pSv/h

Series	EGM-07.G2	EGM-08.G2	EGM-104.G2
<b>Detector type</b>	LND*71632	LND*7807	LND*7807(LD) LND*71210(MD) LND* 71632 (HD)
<b>Measuring range H*(10)</b>	1 pSv/h-10 Sv/h	10 nSv/h-1.5pSv/h	10 nSv/h-15 pSv/h(LD) 50 nSv/h-20mSv/h(MD) 1 pSv/h - 10 Sv/h (HD)
<b>Dimensions(0x 1)</b>	69/60 x 285mm	69/60 x 580mm	69/60 x 580mm
<b>Weight</b>	0.68 kg	0.96 kg	1.22 kg
<b>Sensitivity (Cs-137)</b>	0.02 6 CPS per 1 pSv/h	16 CPS per 1 pSv/h	16 CPS per 1 pSv/h (LD) 1.4 CPS per 1 pSv/h (MD) 0.026CPS per 1 pSv/h (HD)



Third party trademarks are the property of their respective owners.

**NUVIATech Instruments provides a large range of radiation detection and measurement solutions for decades in many countries.**

From modelling to implementation, we supply exclusive know-how and state-of-the-art technologies in monitoring systems dedicated to the major fields of application:

**Fields of application**

- WASTE MANAGEMENT
- ENVIRONMENTAL MONITORING
- LABORATORIES
- HOMELAND SECURITY
- RADIATION PROTECTION
- RADIATION MONITORING SYSTEMS
- GEOPHYSICS

**NUVIATech Instruments manufacturing sites**

CANADA / GERMANY / CZECH REPUBLIC / UK

Abrand of NUVIA Group, NUVIATech Instruments is headquartered in France.



# NuSOFTGAMWIN

COMPREHENSIVE GAMMA SPECTROSCOPY  
ANALYSIS FOR LABORATORY AND NUCLEAR  
INDUSTRY APPLICATIONS

SPECIFICATION  
SHEET

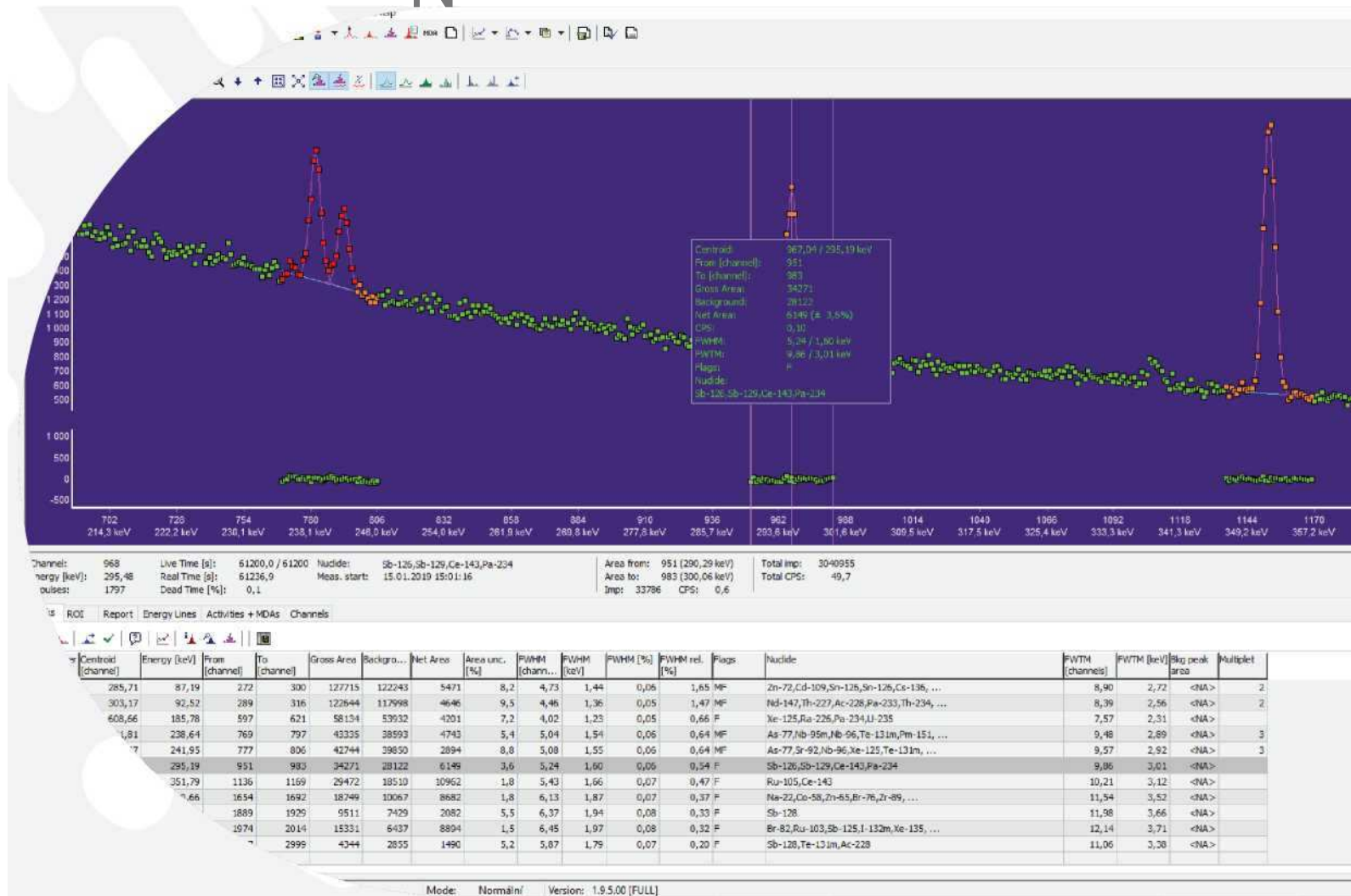

The NuSOFT GAMWIN software is designed for comprehensive spectrum analysis and the assessment of the spectrometric data obtained from semiconductor or scintillation detectors. It supports variety of spectrum files format and includes user friendly tools for simple setup and calibration. Wide variety of spectral correction methods, comprehensive QA, reporting tools and fully managed nuclide libraries available in one package.

## Benefits

- Variety of data formats available (spectra file, libraries and calibration)
- Multi-Language support
- Wide variety of spectral correction methods
- Simple setup and calibration
- Comprehensive QA tools
- Flexible reporting tool
- Scripting language included
- Application Programming Interface & batch processing
- Various peak search methods
- Support of multichannel analyzers of various manufacturers
- Drag & Drop features

Ref: E\_INVA\_2020 / 375047-01 / Errors excepted. Technical changes reserved.

**Product Description**

NuSOFT GAMWIN is a user friendly software package used for routine processing of results of gamma spectrometric measurements (spectrometric data acquisition, processing, analysis and evaluation).

The system includes the usual features for nuclides identification and quantification, searching peaks and determining their area, fitting peaks (including the fitting of multiplets) and subtraction background peaks.

**Versions and options**

**NuSOFT GAMWIN Lite** - This basic version is designed for full control of acquisition and all MCA hardware features and properties. Basic functionality for spectrometry data acquisition and analysis. Free of charge for NUVIATech radiometry HW family.

**NuSOFT GAMWIN Scint** - Advanced Spectroscopy Analysis Software. Sophisticated analytical software tool for gamma radiometry and spectrometry based on scintillation detectors - e.g. NaI(Tl), LaBr<sub>3</sub>(Ce) and other. Limitation: Processing of up to 2048 channels spectra. Unavailable analytic functions and parameter modules requiring properties and resolution of semiconductor detectors. modules requiring properties and resolution of semiconductor detectors.

**NuSOFT GAMWIN Full** - Comprehensive gamma spectrum analysis solution for semiconductor photon detectors gamma-ray spectra (routine processing of results of gamma spectrometric measurements). Unlimited functionality

**Product specifications**

**Supported spectrum file formats** - The NuSOFT GAMWIN software uses its own file formats for spectra, calibration, nuclide libraries, etc. Besides these own native formats, it can also work with third-party formats\*, such as:

- Ortec\* spectra, type CHN and SPC
- Canberra\* spectra, type CNF
- SPE type spectra
- IEEC type spectra
- Thermo\* spectra
- AlphaVision Ortec\* spectra
- EffMaker\* spectra
- Ortec\* nuclide libraries
- Genie2K\* nuclide libraries
- Ortec\* calibrations

The software allows opening any number of spectrum files and it can be connected simultaneously to multiple analyzers. The available features include linear or logarithmic scale view, setting of custom color scheme and enlargement of any part of the spectrum.

**Control of analyzers** - HW Drivers: NuSOFT GAMWIN includes a general interface for controlling spectrometric hardware (analyzers). For each type of spectrometric analyzer there are specific drivers available. All versions of the NuSOFT GAMWIN software include a standard software interface and support (drivers) for spectrometric hardware (analyzers) of manufacturers / brands: NUVIATech Instruments, Ortec, Canberra and GBS Elektronik. Software interface and support (drivers) for controlling spectrometric hardware from other manufacturers are available on user request.

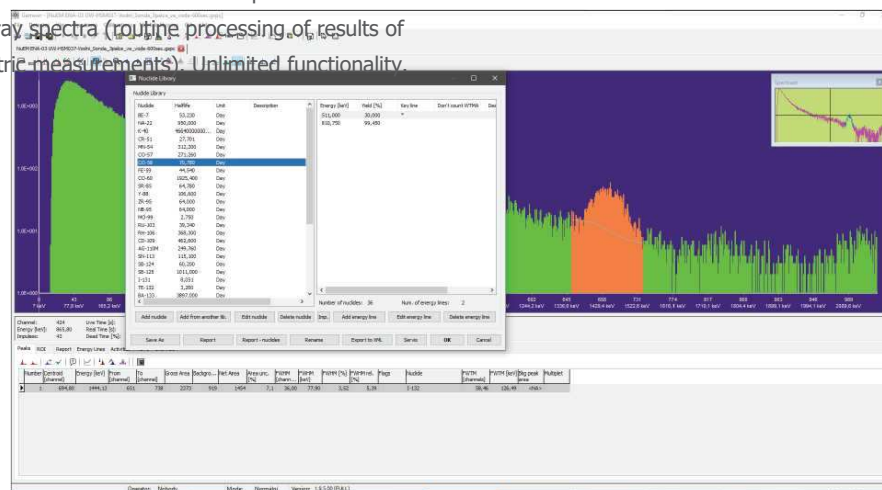

\* Names can be registered trademarks of their respective owners.

**Product specifications**

**Searching peaks:** The function allows automatic peak search (first or second derivation method) - determination of the peak, start and end channels of the peak. A function for determining peaks based on user-defined Regions of Interest (ROIs) or on the nuclide library is also available. The list of peaks is shown in a table and in a report. The areas of peaks found can be also automatically marked as a ROI. For each peak, it is possible to display a window with detailed information. Peak area determination: This function is designed to determine the area of peaks; its outputs are the total and net areas of peaks, the number of background pulses, the Full Width at Half Maximum (FWHM) and the Full Width at Tenth Maximum (FWTM). The uncertainty of neat peak area is also calculated. The peak area determination may include, as an option, a critical level test. The results are shown in a table and in a report. If FWHM calibration is performed, the program lists any larger deviations in FWHM from the expected value for the identified peaks.

**Peak fitting:** The identified peaks can be fitted using the non-linear method of least squares. It is possible to fit multiplets as well as singlets. The fitting procedure uses the performed FWHM calibration and, if applicable, low-tail calibration (if performed). After fitting, it is possible to display the residues at an absolute scale or at the scale of uncertainty of the measured value.

**Subtraction of peaks in the background:** This function allows reading of interfering peaks in the background. Apart from the subtraction of peaks during the gamma spectrum analysis, it is also possible to use a function for the subtraction of peaks in the alpha spectrum.

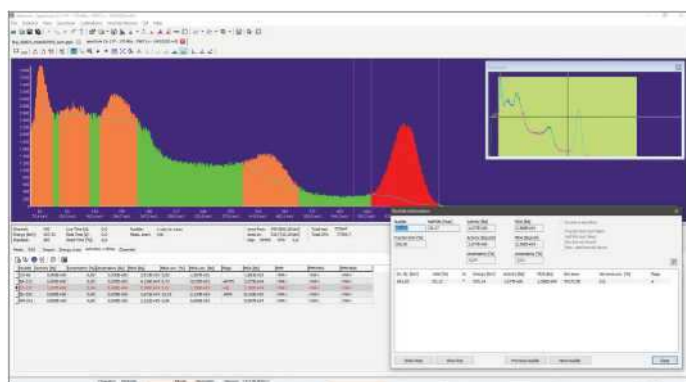

**MDA/MSA determination:** The module contains routines to determine the minimum detectable (significant) activity using the Currie method and KTA. The results are shown in the form of a table and in a report.

**Nuclide identification and activity calculation:** The module makes it possible to identify nuclides on the basis of a selected nuclide

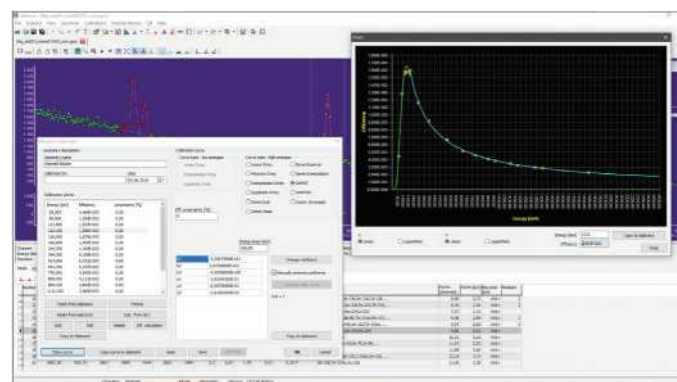

library. The activity of the detected nuclides is determined in Bq, along with their specific activity in the specified unit, if applicable (e.g. Bq/I, Bq/kg). Activity can be calculated on the basis of key line, line with the maximum yield and weighted average. For identification, it is possible to use the half-life test (possible presence based on conversion half-life), the yield test (fraction limit test), key line test (presence of a key line in the spectrum). The results are shown in the form of a table and in a report. If activity is determined using weighted average calculation and interfering nuclides are detected in the spectrum, it is possible to correct the activity for interference. The linear method of least squares is used for these purposes. The resulting activity can be also corrected using user-defined constants or correction for specified correction constants or correction for attenuation of the flow of photons in the shielding material. The resulting activities can be also recalculated using the nuclide vector. The uncertainties for the calculated activity values are also determined. If necessary, the results are corrected for the presence of an absorbent layer between the measured sample and the detector, or for self-absorption in the sample; the user only has to specify the composition of the absorbing material and its physical parameters (attenuation coefficients are already available).

**Nuclide libraries:** NuSOFT GAMWIN allows editing of custom nuclide libraries; it is also possible to use libraries from the Ortec\*\* and Canberra\* systems. For each nuclide, it is possible to enter an individual value to perform the fraction limit test (yield test). A tool for importing the nuclide library from an MS Excel\* file is also available. The installed system includes several nuclide libraries, which can be used as a source for creating custom user libraries.

**Certificates:** NuSOFT GAMWIN allows editing, saving and retrieving files with data on radionuclide standards - «certificates». Using the data stored in the certificate file, it is possible to carry out energy and efficiency calibrations of the spectra easily. The certificate files are also used to analyze alpha spectra - the certificate file contains data on the tracer used.

**Energy, FWHM and tail calibration:** The system enables energy and FWHM calibrations. Calibration can be performed manually by inputting the channels and the corresponding energies in keV, or by loading the retrieved peaks in the spectrum and adding energies in keV. It is also possible to apply automatic calibration using the certificate file or the nuclide library. NuSOFT GAMWIN also makes it possible to load energy calibration data from other systems. Linear and quadratic calibration curves are available for energy calibration and several types of curves for FWHM calibration. In addition, it is possible to carry out low tail calibration.

**Efficiency calibration:** The system allows to carry out manual efficiency calibration and to perform efficiency calibration using the certificate file. It also includes the possibility to load the calibration curves from other systems. Among other features, it is possible to use two polynomials (for the low-energy and high-energy regions of the spectrum), where continuity is tested in the transition point.

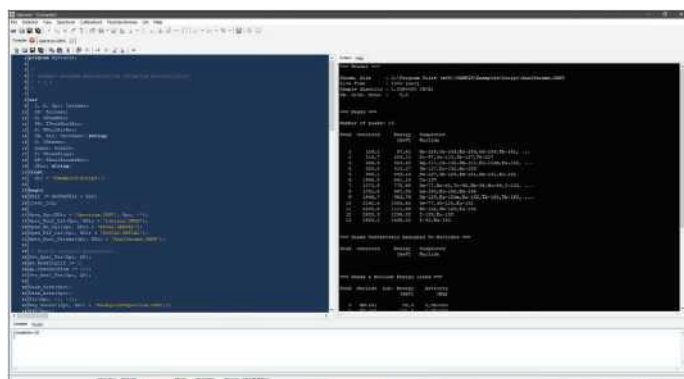

**Report:** The output from the spectrum analysis can be a text report containing user-defined data (peak search and analysis, description of

calibrations, determination of nuclides and activity, MDA determination, data on the spectrum file, analysis parameters, etc.). Optionally, it is possible to set automatic saving in a text file when it is generated.

**Batch jobs - scripts:** NuSOFT GAMWIN includes a custom environment for editing and running batch jobs - scripts in Pascaltype language. Using the scripts, it is possible e.g. to automate routine activities, generate special reports, export data to other systems, etc.

**Plug-ins:** The system allows running of customer function created as plug-ins. In this way it is possible to extend the application core with additional customer modules and functions. An example of real-life application is a fully automated control of a measuring machine.

**API:** The system has an Application Programming Interface (API) to create additional customized applications in the NuSOFT GAMWIN system. User programs can take use of dynamically linked libraries or console utilities (e.g. for the batch processing of the spectrum file).

**QA - Quality Assurance:** The system includes functions for quality assurance. The user can define various parameters (peak position, FWHM, count rate in the specified ROI, nuclide activity, etc.) and the estimated value, including limits. After analyzing the possible results of the analysis (reference parameters) to migrate to the appropriate QA file and then you can generate a report with a comparison of current-measured and estimated values, including their variations and any threshold is exceeded. The user can generate a report for any measurement or a summarized report for a selected period. The data can be also exported in the XML format for further processing.

**Platforms:** NuSOFT GAMWIN is designed as a standard user application for Microsoft Windows\* platforms.

**Language versions:** The software exists in three languages: Czech, English, French. Other languages can be easily added on demand using a translation file.

## Product applications

- Laboratory applications
- Nuclear industry

\*\* Names can be registered trademarks of their respective owners.

- **An Intelligent High Voltage Supply for HPGe Detectors**
- **Provides Detector State-of-Health (SOH) Information**
- **Security Function Allows Use of Authentication Codes**
- **Rugged Housing to Protect Electronics**

The SMART-1 option for ORTEC HPGe detectors is a major enhancement to operational quality assurance and to data and chain-of-custody integrity. It is supported directly through MAESTRO MCA Emulation software which is supplied with the digiDART, digiDART-LF, DSPEC-jr-2.0, DSPEC-LF, DSPEC-Pro, DSPEC-50, and DSPEC-502 digital nuclear multichannel analyzer systems. For other multichannel analyzers, the SMART-INTERFACE provides the same control as the SMART-1.

The SMART-1 HPGe detector includes the high voltage supply, so an external high voltage power supply is not required. The SMART-1 HPGe detector monitors and reports on vital system functions and the SMART-1 identification serial number can be read by the instrument. For more security it can save authentication codes and report the code at a later time.

ORTEC SMART-1 HPGe detectors monitor the following conditions:

- Preamp +24 and +12 V values (read-only)
- Detector element temperature (read-only)
- Detector high voltage value (read-only)
- Detector high voltage state (on/off)
- Detector overload state (read-only)
- Detector HV shutdown state (read-only)
- Detector serial number (read-only)
- Detector authentication code (read/write)

These parameters are displayed as required on the LCD of the attached instrument or computer (local or remote).

### SMART-1 Physical

The SMART-1 is housed in a rugged ABS molded plastic enclosure. The SMART-1 is permanently attached to the detector endcap via a molded, strain-relieved sealed cable.

This eliminates the possibility that the detector will suffer severe damage from moisture leaking into the high voltage connectors. The SMART-1 can be positioned in any convenient place and does not interfere with shielding or other mounting hardware.



# SMART-1 and SMART-INTERFACE

## SMART-INTERFACE for Other MCA Types

SMART-INTERFACE allows the SMART-1 detector technology to be used with virtually any MCA — even analog.

SMART-INTERFACE provides communications between the ORTEC SMART-1 detector and an analog amplifier with any MCA or a Digital Signal Processor that cannot directly connect to the SMART-1. Easy to use software is provided to access the SMART-1 detector's State-of-Health (SOH) data and control the high voltage.

The SMART-INTERFACE is supplied with one detector output signal cable, one inhibit output signal cable [for use with -PLUS or Transistor Reset Preamplifiers (TRP)], one preamplifier power cable for an ORTEC preamplifier power supply, one preamplifier power cable to connect to another manufacturer's preamplifier power supply, a USB extension cable for connection to a PC and software to control the high voltage and display the detector SOH data.

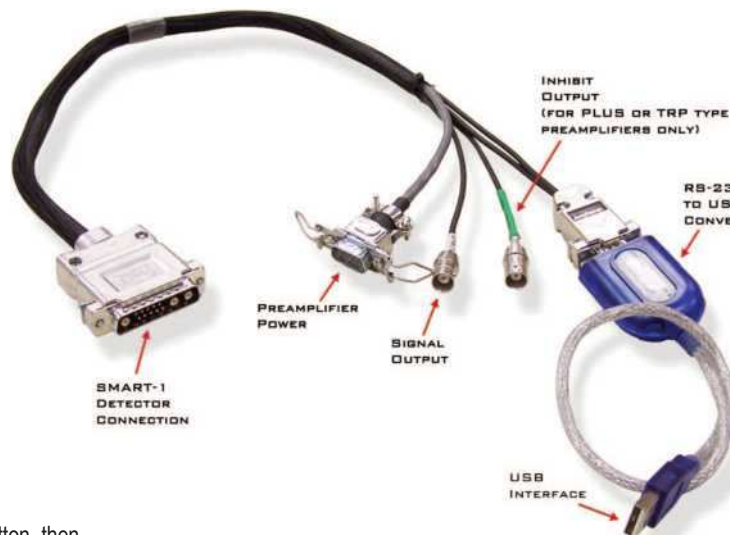

## SMART-INTERFACE Software

To start the SMART-INTERFACE software, click the Window's Start button, then "ORTEC SMART-INTERFACE." Note, the software is initially minimized to the system tray. To terminate the SMART-INTERFACE software, right click the SMART-INTERFACE icon and click "Shut Down."

To see the SMART-INTERFACE dialogue box, click the SMART-INTERFACE icon in the system tray.

### SMART-INTERFACE Dialogue Box

**HV On/Set** Turns on the bias voltage to the detector and sets the HV to the target voltage. The user enters the target volts in the "Target" box.

**Actual** Displays the voltage applied to the detector.

**HV Off** Turns off bias voltage to the detector.

**Close** Closes the dialogue box for the SMART-INTERFACE software. Note, this does not cease operations for the SMART-INTERFACE software.

**Clear SOH** Clears the data from the Detector/DIM State-of-Health (SOH) chart and resets the Initial Date/Time to the current date and time.

**Drop-Down Menu (Left)** Selects the COM port that will be used to control the SMART-INTERFACE.

**Drop-Down Menu (Right)** Indicates the bias shutdown logic that is being used. This should always be set to SMART for use with a SMART-1 detector.

### ORTEC Smart Interface

	Target:   3000	Volts	Polarity
i HVOn/Set			
HVOff	Actual: 0	Volts	

Close	Clear SOH	COM5	<b>3</b>	SMART ▼
-------	-----------	------	----------	---------

### Detector/DIM State of Health [SOH]

DIM +24 V:	OK
DIM -24 V:	OK
DIM +12V:	OK
DIM -12V:	OK
Detector:	OK
Temperature:	OK( 93.5 K< 116.5 K)
High Voltage:	OK
Shutdown:	OK
Preamplifier:	OK
Security:	OK
Firmware Version:	\$FSMDT004
Serial Number:	TestSN 123456789
Model:	DIMNEGGE
Initial Date/Time:	6/25/2009 2:04:37 PM

SMART-Interface Dialogue Box.

# SMART-1 and SMART-INTERFACE

## SMART-INTERFACE Controls Menu

Access the SMART-INTERFACE controls menu by clicking on the upper left corner of the SMART-INTERFACE dialogue box. A drop-down menu will appear.

### SMART-INTERFACE Controls

**Move** Moves the dialogue box.

**Close (ALT+F4)** Closes the dialogue box

**Set Recommended HV** Allows the user to enter a value for the bias (normally the recommended value from the SMART-1 detector QAD sheet).

**Get Recommended HV** Acquires the value entered by the user in the Set Recommended HV step and applies this value to the "Target" box of the SMART-INTERFACE dialogue box.

**DIM Authentication Code** Allows the user to change or delete the authentication code.

**User Password** Opens the Manage User Password dialogue box and allows setting or deleting password protection of the HV On/Off function and provides a means of changing the password. Note, the default password is "ORTEC".

Setting the HV On/Off is password protected by default. If the "HV On/Off without Password" box is not checked in the Manage User Password dialogue box, the HV On/Off Password dialogue box will appear.

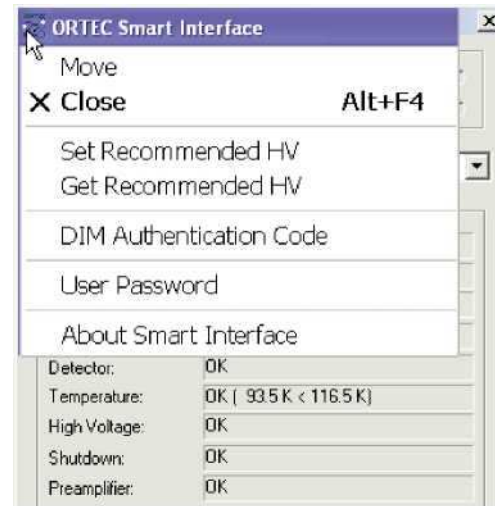

SMART-Interface Controls Menu.



User Password.



DIM Authentication Code.



HV On/Off Password.

# SMART-1 and SMART-INTERFACE

## SMART-INTERFACE Specifications

**Preamplifier Power** 9-pin D connector provides  $\pm 12$  V and  $\pm 24$  V power to the preamplifier and high voltage supply. Two 12 ft (3.6 m) preamplifier power cables are provided, one for ORTEC connections and one for another manufacturer.

**Signal Output** Supplies the voltage pulse from the preamplifier suitable for input to a spectroscopy shaping amplifier or a Digital Signal Processor. 100- $\Omega$  impedance. A 12 ft (3.6 m) BNC cable is provided.

**Inhibit Output** A logic signal is provided during the reset time from a -Plus type (Transistor Reset) preamplifier. 1 k $\Omega$  impedance. A 12 ft (3.6 m) BNC cable is provided.

**USB Interface** Converts the RS232 interface to USB and provides a USB connection to a PC. Interface circuit is powered by the USB. A 10 ft (3 m) USB extension cable is provided.

**Weight** Net 2 lbs. (0.9 kg) Shipping 3 lbs. (1.4 kg)

## Ordering Information

Model	Description
-SMP	Positive Bias SMART-1 detector option, add "-SMP" to the detector model number [e.g., GEM75P4-95-SMP or GEM75-95-SMP].
-SMN	Negative Bias SMART-1 detector option, add "-SMN" to the detector model number [e.g., GMX70P4-95-SMN or GMX70-95-SMN].
SMART-INTERFACE	Provides communication between the ORTEC SMART-1 detector and an analog amplifier with MCA or a Digital Signal Processor that cannot directly connect to the SMART-1.

Specifications subject to change  
052020

---

**ORTEC**

[www.ortec-online.com](http://www.ortec-online.com)

Tel. (865) 482-4411 • Fax (865) 483-0396 • [ortec.info@ametek.com](mailto:ortec.info@ametek.com)  
801 South Illinois Ave., Oak Ridge, TN 37830 U.S.A.  
For International Office Locations, Visit Our Website

**AMETEK**