

High Voltage Power Supplies for RF source (Gyrotron) for the COMPASS Upgrade Tokamak

TECHNICAL SPECIFICATION

CU_HEAT-02-01-02_PTD_TechnicalSpecification

This document is owned by IPP, but contains Background Intellectual Property (BIP) belonging to MuWave LTD. This BIP is provided for the sole use and benefit of IPP, and IPP has licence to use the BIP contained within this document for IPP's own purposes only, including the use and publication of this document in its entirety as part of the tender documentation for a public contract to be awarded by IPP to a supplier selected in the public procurement procedure for the public contract and as an annex to the implementation contract, which is to be concluded with the selected supplier and which is subject to the statutory obligation of publication in the Register of Contracts. Except as provided in the preceding sentence, no part of this document should be reproduced or used by any Third Party without the consent of MuWave LTD.

Revision Number	Reason for Revision	Date
1	Tender release	18/12/2025
1.1	<p>Updated:</p> <ul style="list-style-type: none"> - The requirement REQ EXT 1 (see section 5.1.5) has been added to define the delivery of a software backup in the event of a hardware failure. - To eliminate any potential ambiguity, the “≤” symbol has been added to the values T15-01, T15-02, T15-03 in Table 15. - To eliminate any potential ambiguity, the wording of REQ 133 has been revised. - Figure 21 has been updated to include the position of the gyrotron, and the caption has been revised. - Caption of Figure 22 has been updated. 	1/1/2026
1.2	<p>Updated:</p> <ul style="list-style-type: none"> - Duplicate numbering of the three requirements originally labelled REQ 96 has been removed: two extraneous RE96 requirements on the page 33 were renamed to requirement numbers REQ EXT 2 and REQ EXT 3. - An error in REQ EXT 2 has been corrected. The revised wording is as follows: “For the connection to the gyrotron, the Seller shall use appropriate oil-sealed connectors.” The corrected wording is consistent with the rest of the Technical specification: chapter 2.2 item 16, REQ 4 – Doc-01, chapter 3 and chapter 3.1 and REQ 204 	21/1/2026

Table of content

Table of content	3
List of abbreviations	6
List of terms	7
1. High Voltage Power Supplies for RF source (Gyrotron) for the COMPASS Upgrade Tokamak	8
1.1. System Overview	8
2. Seller Scope	10
2.1. Services	10
2.2. Physical deliverables / Outline Bill of Materials	10
2.3. Document deliverables	13
2.4. Spare parts	14
3. Buyer Scope.....	14
3.1. Items not included in the Supply	14
4. Specifications for the Seller’s Bid	15
5. Technical Requirements	16
5.1. HV PS system – overall description.....	16
5.1.1. Typical operating sequences	17
5.1.2. Topology selected for the gyrotron Power Supplies.....	20
5.1.3. Parameters definition	21
5.1.4. Shutdown and shutdown signals.....	23
5.1.5. Control system	24
5.2. Main Power Supply (MPS)	25
5.3. Body Power Supply (BPS).....	26
5.4. Anode Power Supply (APS).....	28
5.5. Cathode Heater Power Supply (CHPS).....	29
5.6. Transitions between Load and No-Load States.....	30
5.7. Safety Switches	31
5.8. Cabling and Routing.....	32
5.9. Dummy Loads	33
5.9.1. MPS Load	33
5.9.2. BPS Load	33
5.9.3. APS Load	33
5.10. Additional Requirements	34
5.10.1. Lifetime	34
5.10.2. Monitoring and protection.....	34

5.10.3.	Enclosures and Fences	34
5.10.4.	Other.....	34
6.	Interface.....	35
6.1.	HV grid / Flywheel Generator.....	35
6.2.	Gyrotron	37
6.3.	Low Voltage Network.....	37
7.	Building constraints.....	37
7.1.	Space constraints / layout.....	37
7.2.	Load Constraints	38
7.3.	Crane parameters.....	39
7.4.	Environmental conditions	39
8.	Documentation.....	39
8.1.	Project design documentation	40
8.2.	Quality assurance plan	40
8.3.	As-built documentation	41
8.4.	Accompanying documentation.....	41
8.5.	Assembly documentation	41
9.	Delivery	41
10.	Assembly.....	42
11.	Commissioning	42
12.	Acceptance Tests	42
	CHPS tests.....	43
12.1.	MPS Power Module Tests	43
12.2.	MPS Full Assembly Tests	44
12.3.	BPS Tests.....	44
12.4.	APS and ASM Tests	44
12.5.	Pulse Demonstration Tests	44
12.6.	Arc Energy Tests	46
12.7.	Reverse Voltage Test / Overvoltage Test	46
12.8.	Control System Tests.....	46
12.9.	Coolant System Tests	46
12.10.	Ancillary System Tests	47
12.11.	MPS Transformer Tests.....	47
12.12.	HV cables and receptacles tests.....	47
12.13.	CHPS tests	47
12.14.	Acceptance Tests documentation and organisation.....	47
12.15.	Rejection of Plant	47

13.	Codes and Standards	48
14.	Project Management	49
14.1.	Project Milestones	49
14.2.	Inspection and Progress Meetings	51
14.3.	Design review	51
15.	Quality Management.....	52
15.1.	Quality Management System.....	52
15.2.	3D and 2D CAD	52
15.3.	Supply Chain Management	52
15.4.	Lifting Equipment.....	52
15.5.	Calibration of test and measuring Equipment	52
15.6.	CE Marking / Regulatory Requirements	52
16.	Shipping, Storage and Handling	52
16.1.	Identifier	52
16.2.	Handling of parts and storage	52
16.3.	Packing and Crating.....	53
16.4.	On site delivery.....	53
16.5.	Training	53
17.	List of Annexes	54

List of abbreviations

- Anc Ancillary systems
- APS Anode Power Supply
- ASB Assembly
- ASM Anode Switching Mechanism
- BoM Bill of Materials
- BPS Body Power Supply
- CHPS Cathode Heater Power Supply
- COM Commissioning
- DEL Delivery
- DL Dummy Load
- DR Design Review
- EC Electron Cyclotron
- EMC Electro Magnetic Compatibility
- FAT Factory Acceptance Test
- HV High Voltage
- HV PS High Voltage Power Supplies
- KOM Kick Off Meeting
- MPS Main Power Supply
- QA Quality Assurance
- REQ Requirement
- SAT Site Acceptance Test

List of terms

the Buyer	The contracting entity – Institute of Plasma Physics of the Czech Academy of Sciences (IPP)
the Seller	The entity contracted to manufacture the high voltage power supplies, selected as a winner of the tender
shall	means “must” or “mandatory”
should	Expresses a requirement with lower priority than “shall”. Inability to meet these requirements shall be agreed with the Buyer.
as required	The quantity shall be determined by the Seller as required to meet the Technical Requirements.
HV PS system	Means the whole delivered system including all individual components that are scope of the supply within the contract, i.e. all individual power supplies (MPS, BPS, APS and CHPS), control system, cables, safety switches, dummy loads, etc.

1. High Voltage Power Supplies for RF source (Gyrotron) for the COMPASS Upgrade Tokamak

This document defines the technical requirements for the procurement of a High Voltage Power Supplies in the public tender “High Voltage Power Supplies for RF source (Gyrotron) for the COMPASS Upgrade tokamak”.

The tender “High Voltage Power Supply for RF source (Gyrotron) for the COMPASS Upgrade tokamak” includes the development, design, manufacturing, temporary storage, transportation to the Buyer, supervision of installation on the Buyer’s premises, commissioning and site acceptance testing of the High Voltage Power Supplies for a high-power microwave source (gyrotron).

Throughout this document, the text is divided into chapters and the requirements are identified by a progressive number preceded by REQ (for example “REQ 47”).

1.1. System Overview

The Electron Cyclotron (EC) system of the COMPASS Upgrade shall provide heating by radio-frequency (RF) waves to the plasma. The EC system consists of one triple-frequency gyrotron, the High Voltage Power Supply, the transmission line, the launcher, the control system, and other ancillary systems.

The gyrotron serves as the RF source of the EC system. It converts the kinetic energy of relativistic electrons, moving through a resonant cavity in a static magnetic field, into RF power.

The electron beam is generated in a vacuum tube containing three electrodes. Electrons are emitted from a hot cathode by thermionic emission and are accelerated by a DC electric field. A high accelerating voltage is applied between the cathode (negative) and the body (positive). The gyrotron is further equipped with a third electrode, the Anode (negative), which serves two purposes:

- RF output modulation – controlling the ON/OFF state of the RF output. When the Anode is at the same potential as the cathode, no electron beam flows through the gyrotron and the RF output power is zero.
- Beam shaping and optimization – by applying a voltage in the range of -3 kV to -30 kV, the Anode voltage allows fine-tuning of the beam parameters to achieve higher RF output power at all three operating frequencies.

The operation of a triode-type gyrotron therefore requires independent control of both the Anode and Body voltages.

The Main Power Supply (MPS) is the primary high voltage source, providing approximately –55 kV between the cathode and the collector. One MPS unit can simultaneously power two identical gyrotrons connected in parallel; therefore, its nominal output current can reach up to 110 A. Cathode heating is provided by a Cathode Heater Power Supply (CHPS), which operates at the MPS potential (“floating” configuration).

The positive accelerating voltage between the Body and the collector is supplied by the Body Power Supply (BPS). This configuration, known as a depressed collector setup, takes advantage of the fact that the BPS carries only a small current, thereby improving the overall electrical efficiency of the power supply system.

Each gyrotron must have its own dedicated BPS and Anode Power Supply (APS).

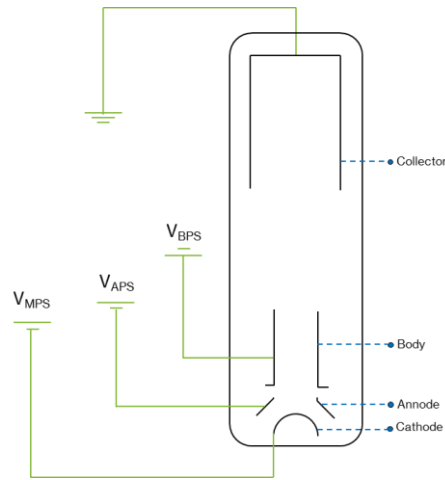

Figure 1: Typical gyrotron HV PS layout.

Each of the two gyrotrons connected to the MPS is capable of delivering a nominal RF output power of approximately 1 MW, hence the designation *megawatt-class gyrotron* used throughout this document.

Due to the relatively low electrical efficiency of gyrotrons, the MPS must provide a total electrical power of about 6 MW to support their operation.

The purpose of this Technical Specification document is to define the parameters of the Main, Body, and Anode power supplies for the triple-frequency, triode type gyrotron. The operation of a triode type gyrotron requires independent control of Anode and Body voltages.

Note that the curve is indicative of a “typical” gyrotron.

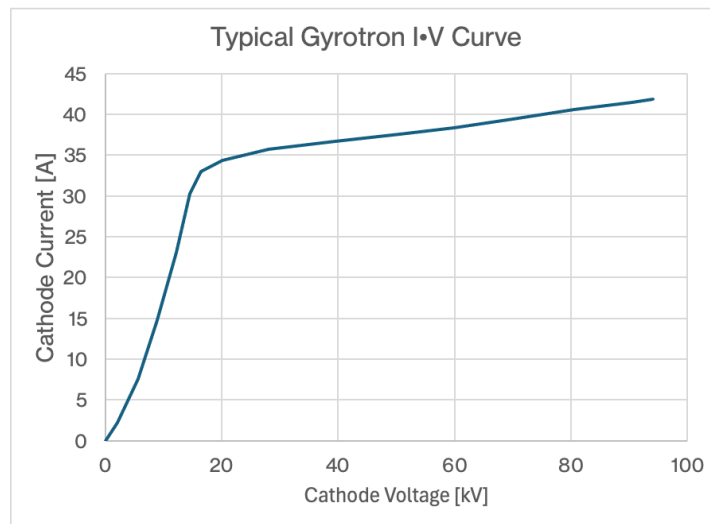

Figure 2: Typical I-V (Current – Voltage) curve of a 1.0 MW gyrotron.

A typical output power of a 1 MW gyrotron as a function of the beam voltage (sum of V_k and V_b) is shown in Figure 3. Note that there is a starting voltage around 70 kV, lower voltages either result in operation in the incorrect cavity mode or no microwave generation.

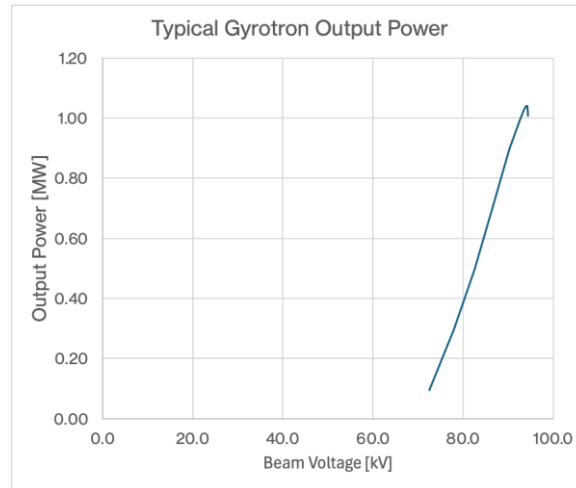

Figure 3: Typical trace of the gyrotron output power as a function of beam voltage power, note that prior to ~70 kV, there is no power in the correct operating mode.

2. Seller Scope

2.1. Services

REQ 1: The Seller shall deliver the services defined in Table 1.

ID	Required Service	Required for which milestone? (see Sec. 14)
Ser-01	Transportation of all parts of the HV PS system to the site of installation	DEL
Ser-02	Supervision during assembly, followed by inspection and handover for commissioning and testing	ASB
Ser-03	Any isolation barriers required between individual parts of the HV PS system (as required)	ASB
Ser-04	Commissioning and testing of all equipment at the Buyer's site (see 10.)	SAT
Ser-05	Training of the Buyer's employees / staff (see 14.5.)	SAT
Ser-06	Provision of the project documentation of all levels (see 8.)	SAT
Ser-07	The warranty period for the HV PS system (see chapter 7 of Annex No.2 – Binding draft of the Contract_HVPS)	

Table 1: Service Deliverables

2.2. Physical deliverables / Outline Bill of Materials

The Seller is responsible for the delivery of the High Voltage Power Supply (HV PS) system, which consists of the Main (MPS), Body (BPS), Anode (APS) power supplies and associated ancillary systems. The Seller's scope of deliverables includes, but not limited to, the following:

1. One MPS serving two 1 MW class gyrotrons including the required control, instrumentations, and interfaces; 1 MW in RF power corresponds to ~2.5 MW provided by the MPS.
2. One BPS for one gyrotron including the required control, instrumentations and interfaces.
3. One APS with integrated fast switching mechanism for one gyrotron including the required control, instrumentations and interfaces.
4. One CHPS including the required control instrumentation and interfaces.

5. Two remotely operated safety switches at each of the two MPS outputs. Each switch serves a dual purpose of isolating the associated gyrotron and earthing it (when the associated feedline is isolated from the MPS). The switches include feedback signals of switch state.
6. One remotely operated safety switch at the BPS output. The switch serves a dual purpose of isolating the associated gyrotron and earthing it (when the associated feedline is isolated from the BPS). The switches include feedback signals of switch state.
7. One remotely operated safety switch at the APS output. The switch serves a dual purpose of isolating the associated gyrotron and earthing it (when the associated feedline is isolated from the APS). The switches include feedback signals of switch state.
8. The HV DC cables from the power supplies to the switches of items #5, 6 and 7.
9. The HV DC cables from the MPS, BPS and APS switches to one gyrotron.
10. The HV DC cables from the CHPS to one gyrotron.
11. Any snubbers, crowbars, reverse-voltage modules, static switches or other components required to limit arc energy to the gyrotron to meet the limits on shutdown speed and arc energy.
12. A suitably rated dummy load for testing the MPS during Site Acceptance Testing (SAT) and post maintenance testing, connected at the end of the cable after one of the switches of item #5.
13. A suitably rated dummy load for testing the BPS during SAT and post maintenance testing, connected at the end of the cable after the switch of item #6.
14. A suitably rated dummy load for the APS testing during the SAT and post maintenance testing, connected at the end of the cable after the switch of item #7.
15. All coolant piping or equipment (as required) and their control.
16. All mechanical and electrical connections.
17. Connection of the HV PS system to the respective primary cooling water loops and electric distribution mains.
18. Electrical back-up solution for all critical parts of the delivery where interruption of power supply could cause significant damage to the HV PS system or connected systems or danger conditions for personnel (e.g. control systems).

REQ 2: The Seller shall describe any additional HV protection barriers required for the HV PS system, which are in addition to those provided by the Buyer.

The Seller is not responsible for:

- Integration of the HV PS system with the Buyer's control system.
- AC cables prior to the Seller's scope.

A preliminary bill of materials is provided in Table 2; a final list shall be provided by the Seller in the Seller's Bid.

REQ 3: The Seller shall provide a revised bill-of-material list (equivalent to Table 2) as part of the Seller's Bid, and a final list at the Design Review.

ID	Sub-System	Item ¹	Quantity
Del-01	MPS	MPS Transformer	As required
Del-02	MPS	MPS module assembly	1
Del-03	MPS	MPS control cubicle(s)	As required
Del-04	MPS	MPS Safety switch (at output)	2 ⁽¹⁾
Del-05	MPS	Snubber/Arc protection circuit	As required
Del-06	MPS	MPS cabling	1
Del-07	BPS	BPS Assembly	1
Del-08	BPS	BPS Control cubicle/module	1
Del-09	BPS	BPS Safety switch (at output)	1
Del-10	BPS	Snubber/Arc protection circuit	As required
Del-11	BPS	BPS cabling	1
Del-12	APS	APS Assembly including Anode Switching Mechanism	1
Del-13	APS	APS Control cubicle/module	1
Del-14	APS	APS Safety switch (at output)	1
Del-15	APS	Snubber/Arc protection circuit	As required
Del-16	APS	APS cabling	1
Del-17	Anc	MPS Dummy Load	1
Del-18	Anc	BPS Dummy Load	1
Del-19	Anc	APS Dummy Load	1
Del-20	Anc	Coolant Equipment	As Required
Del-21	Anc	Documentation Package	See Sec. 2.3
Del-22	Anc	Spare Parts Package	See Sec. 2.4
Del-23	Anc	Cathode Heater Power Supply	
Del-24	Anc	CHPS cabling	1
Del-25	Anc	Switching mechanisms between PSs and Dummy Loads	As required

Table 2: Physical deliverables / Bill of Materials for a single unit gyrotron

- 1) Two safety switches and the associated HV DC cables from the MPS to each safety switch are to be included in the Seller's scope. However, only one HV DC cable from a safety switch to one gyrotron is included in the Seller's scope.

2.3. Document deliverables

REQ 4: The Seller shall provide a complete documentation package as specified in Table 3.

ID	Package name	Documentation Required (see Sec. 8)	Required for which milestone? (see Sec. 14.1)
Doc-01	Design review documentation	<ul style="list-style-type: none"> • Cable tracing and connectors design • Grounding scheme • Grounding and EMC analysis • Safety requirements • List of recommended spare parts 	DR
Doc-02	Project design documentation	<ul style="list-style-type: none"> • Technical drawings and diagrams • Installation plan • Grounding scheme • Safety requirements • Simulations • List of spare parts 	DR (draft) DEL (final)
Doc-03	Quality assurance plan (Test plan)	<ul style="list-style-type: none"> • List of FAT and SAT tests • Description of FAT and SAT tests 	DR (draft) DEL (final FAT test documentation) SAT (final SAT test documentation)
Doc-04	As-built documentation	<ul style="list-style-type: none"> • Technical drawings and diagrams • Documentation of the used components • Documentation of all performed tests • Documentation of all performed simulations 	SAT
Doc-05	Accompanying documentation	<ul style="list-style-type: none"> • Operation manuals • Instructions for maintenance of the components 	SAT
Doc-06	Assembly documentation	<ul style="list-style-type: none"> • Installation manual • Installation plan 	DEL

Table 3: Document deliverables

REQ 5: The documents shall be provided in one of the digital formats listed in Table 4.

ID	Document Type	Allowable Format
T4-01	Text	DOC/DOCX, PPT/PPTX, XLS/XLSX or PDF format
T4-02	Photos and videos	JPEG, PNG, TIFF, AVI or MP4 format
T4-03	Drawings	CATIA V5, PDF, DWG or DXF format
T4-04	Time traces of recorded parameters during testing	Text file with comma-separated csv format
T4-05	3D CAD data	CATIA V5 or STP format

Table 4: The allowable formats for the digital documents that are to be used in the scope of this contract.

2.4. Spare parts

REQ 6: The Seller shall be responsible for providing any spare parts required to regularly maintain the operation of the Sellers equipment during the full Warranty period.

REQ 7: The Seller shall provide on DR a provisional list of spare parts envisioned for the 20-year lifecycle of the HV PS system equipment. The list of spare parts shall be approved by the Buyer during the Design Review.

REQ 8: The spare parts for the following classes of components should be delivered:

1. Power Modules: for each modular part of the HV PS system at least 3 pieces of complete power module

Note that this applies at least to the MPS, and it shall apply to the BPS and/or APS in the event that they are built from a significant number of identical modules intended to provide together the required output voltage.

2. Drivers (for thyristor and transistor modules): for each type used, the quantity shall be the lower value of either 10 pieces or 20% of the total installed number in the entire HV PS system

3. Control System parts: any custom-made PCBs (e.g., low-level controllers, data acquisition boards, communication units): for each type used, the quantity shall be the greater of 1 piece or 20% of the total installed number in the entire HV PS system, rounded up to the nearest whole number (e.g., 20% of 6 pieces = 2 pieces)

3. Buyer Scope

To clarify the scope to be delivered by the Seller, this section defines the responsibilities of the Buyer.

The Buyer will:

- Communicate requirements / constraints necessary for the development of the HV PS system.
- Allow inspection of the installation site immediately after signing the contract.
- Supply all interfacing equipment as per the request and specification (agreed by both parties during the DR), including:
 - Cooling water supply.
 - Earthing connection points to meet grounding scheme agreed at Design Review.
 - Low voltage power ($3 \times 400 \text{ VAC} / 50 \text{ Hz}$) to meet requirements specified at Design Review.
 - Tokamak control system interface.
- Attend and witness key FAT and SAT activities (to be agreed).
- Provide unloading and inspection at the Buyer's premises.
- Assemble the HV PS system according to the installation plan/manual under the supervision of the Seller's representatives.
- Make available the following services:
 - Crane and fork lift operators
- Provide suitably qualified engineers and/or technicians to carry out installation under the supervision of the Seller's representative(s).

3.1. Items not included in the Supply

- HV oil-tight receptacles on the gyrotron are not included in the Supply. However, the Seller shall propose receptacles that are compatible with the plugs used on the HV DC cables.
- The fencing of the area where the HV power supplies will be installed is not included in the Supply.

4. Specifications for the Seller's Bid

This Section, "Specification of the Seller's Bid" contains part of the information to which the Framework Purchase Agreement and Tender Documentation directly refer.

The Seller shall provide, but is not limited to, the information in Table 5 as part of their bid submission.

ID	Document	Description
T5-01	System Description	Overall description of the proposed HV PS system
T5-02	Bill-of Materials (BoM)	Indicative BoM is given to provide clarity to the Buyer that the Seller has included in the final price all the components that are necessary to meet the technical requirements
T5-03	Schedule	To demonstrate the Seller's ability to deliver the HVPS within the timeframe required in the Contract, the Seller is obliged to prepare and submit within their Bid a detailed time schedule for the delivery of material, associated reports and design review meetings. Delivery schedule shall contain a detailed time plan of manufacturing and delivering process in the form of a table or/and Gantt Chart.
T5-04	Requirements fulfilment statement	A signed specific statement from the Seller confirming that the proposed product fulfils all requirements contained in the Technical Specification and the Contract.
T5-05	Technical compliance declarations	Technical compliance declarations as required by Table 6. For the validity of the submitted bid, the Seller must enter their own declaration in the 'Confirmation' field (highlighted in yellow). The allowed values are listed in the 'Allowed value / description' field.

Table 5: The technical information that the Seller is provide in their bid submission.

#	Name / description of the request	Allowed value / description	Confirmation
1	The offered HV PS meets all the requirements listed in the Technical Specification and in the Contract.	Confirmation ("Yes")	[Seller's Confirmation("Yes")]
2	The offered HV PS fits into the assembly area	Confirmation ("Yes")	[Seller's Confirmation("Yes")]
3	The offered HV PS can be operated in the environment described in Sec.7.4 and achieve the parameters required in Sec. 5	Confirmation ("Yes")	[Seller's Confirmation("Yes")]
4	The offered HV PS is compatible with the interfaces described in Sec. 6	Confirmation ("Yes")	[Seller's Confirmation("Yes")]

Table 6: Technical compliance declarations in the Seller's bid

The items in the framework agreement are divided as follows (see Annex No. 3 - Price Schedule and Deliverables_HVPS).

Number of the individual Item	Delivered individual Item
No.1	High Voltage Power Supplies (HV PS)
No.2	HV coaxial cables
No.3	HV triaxial cables

REQ 15: In the event that the Seller proposes a different allowed topology, it is the Seller's responsibility and obligation to adapt all necessary requirements and numerical values to their proposed configuration. Any changes shall subsequently be communicated during the Design Review and approved by the Buyer. Note that this mainly implies, but is not limited to, transferring all functionalities of the ASM into capabilities of the APS itself.

Note that the gyrotron output power will, at times, be modulated. This will be achieved using either APS or the ASM. This places additional requirements on the HV PS, as MSP, BPS, and APS shall be compliant with interchanging between no-load and load conditions, see Sec. 5.6.

The definition of the primary voltages used in the operation of the gyrotron is defined in Table 8.

ID	Variable	Symbol	Polarity	Comment
T8-01	Collector Voltage	V_c	Grounded	The voltage on the gyrotron collector.
T8-02	Cathode Voltage	V_k	Negative	The voltage on the gyrotron Cathode.
T8-03	Body Voltage	V_b	Positive	The voltage on the gyrotron Body.
T8-04	Anode Voltage	V_a	Negative (Positive to Cathode)	The voltage on the gyrotron Anode.
T8-05	Beam Voltage	V_{beam}	Negative	$V_{beam} = V_k - V_b$. This voltage is the primary control of the output power of the gyrotron.
T8-06	MPS Output Voltage	V_{MPS}	Negative	The output voltage of the MPS.
T8-07	BPS Output Voltage	V_{BPS}	Positive	The output voltage of the BPS.
T8-08	APS Output Voltage	V_{APS}	Negative (Positive to Cathode)	The output voltage of the APS.
T8-09	ASM Position to APS	S_A	Negative	The position of the Anode Switching Mechanism connecting the Anode to the APS (allowing generation of microwaves).
T8-10	ASM Position to MPS	S_M	Negative	The position of the Anode Switching Mechanism connecting the Anode to the MPS (blocking generation of microwaves).

Table 8: The definition of the primary voltages and polarity used in operation of a gyrotron.

REQ 16: Given values of currents of all components of the HV PS system in the following sections apply only for the operation of the gyrotron itself. However, any snubbers, crowbars, and/or any other additional circuitry affecting the behavior of the HV PS, as well as capacitance of the cables and other components, can lead to significantly higher currents flowing through the respective parts of the HV PS system during operation. All power supplies should be designed in a way that enables safe operation and implementation of all required waveforms of the HV PS system even when higher currents are present and/or required.

5.1.1. Typical operating sequences

The turn-on and off sequence of the power supply assembly is illustrated in the sequence of figures from Figure 5 to Figure 8. The introduction of the ASM inside the APS has the advantage that the ASM controls the gating function of the Anode and thus the output power of the gyrotron. This relaxes the requirements on the ramp-up and ramp-down speeds of each of the power supplies, as the fast transition is achieved via the ASM.

A “pulse” is considered as a single or multiple “on” “off” sequences of the voltage as illustrated in Figure 5 to Figure 8. These are correlated with an operating pulse of the COMPASS-U device, which will last up to 15 s every ~25 min.

REQ 17: The ramp-up/down speeds and relative start sequencing of each power supply shall be controllable both locally (using the internal HV PS control system) and remotely (controlled via an external input signal to each Power Supply).

REQ 18: The HV PS control system shall be capable of independent control of the applied voltages to achieve power ramps and power steps as illustrated in Figure 6 with the ramp rates defined in Table 12, Table 13, and Table 14.

Each gyrotron will be capable of operating at more than one frequency, which will require the independent control of each Anode and Body Power Supply, as each frequency requires different voltage settings.

REQ 19: The HV PS shall be capable of modulating the ASM with programmable periods in a pulse as illustrated in Figure 7 and at frequencies defined in Table 12, Table 13, and Table 14.

REQ 20: The voltage traces associated with REQ 17, REQ 18, and REQ 19 shall be achievable using an internal signal or an external generator via an input reference.

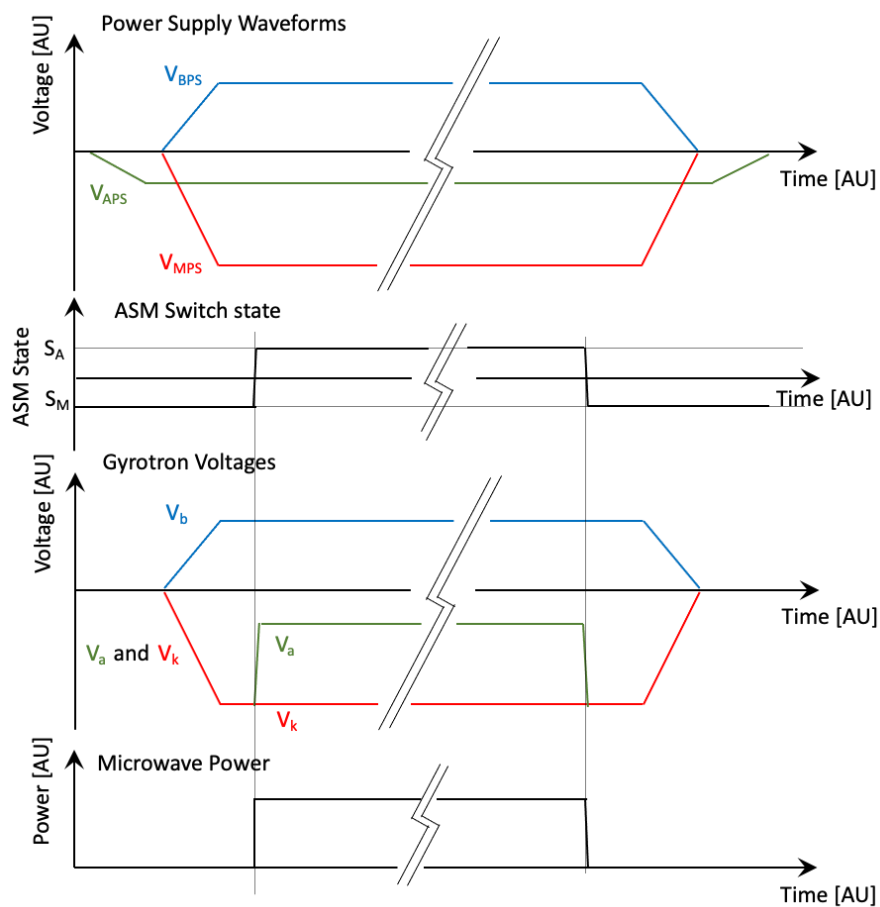

Figure 5: The turn-on (left) and turn-off (right) sequence of the three power supplies and the corresponding voltages applied to the gyrotron electrodes, referenced to the ASM switching states (S_A and S_M). The microwaves (bottom trace) are generated when the ASM disconnect the anode from cathode potential.

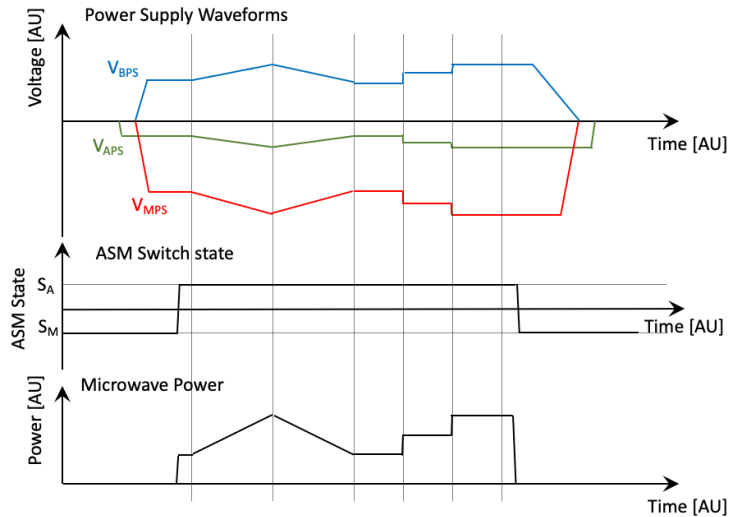

Figure 6: Typical voltage ramps and steps used in the applied voltages generated using either the internal or external function generator.

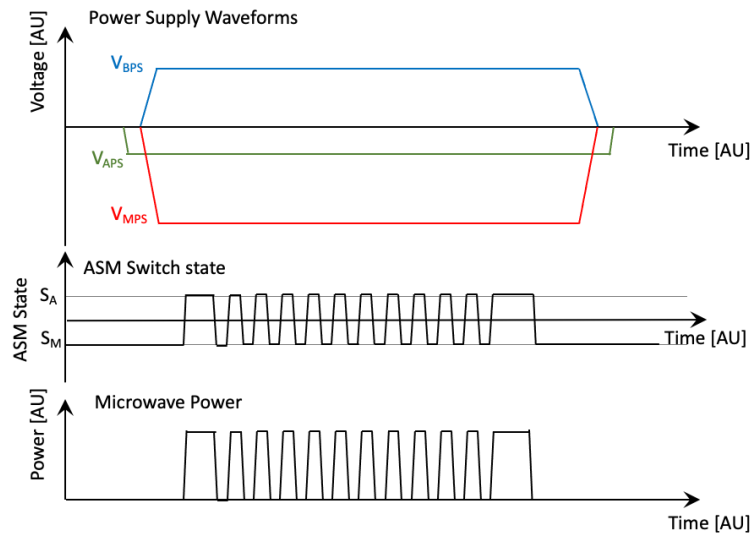

Figure 7: A “typical” modulation pulse controlled via the switching of the ASM between the APS and MPS voltages. Note that V_{MPS} , V_{BPS} and V_{APS} remain constant between the “load” and “no-load” periods, within the prescribed limits on voltage stability given in Table 12, Table 13 and Table 14.

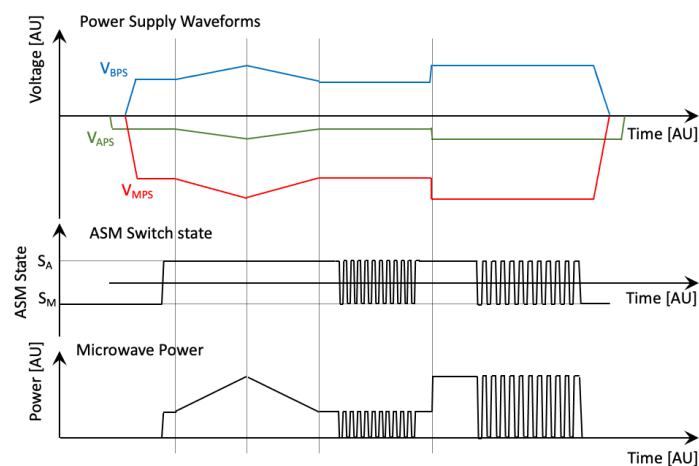

Figure 8: A combined pulse that includes power ramps and power modulations, which shall be achieved using either the internal or external signal generator.

5.1.2. Topology selected for the gyrotron Power Supplies

The topology of the three power supplies and gyrotron(s) is illustrated in Figure 9.

REQ 21: The APS and BPS shall be powered from the standard 3×400 VAC / 50 Hz grid. (See Sec. 6.3.)

REQ 22: The MPS shall be compatible with being powered from a flywheel generator. (See Sec. 6.1.)

REQ 23: The APS and BPS shall be powered from the standard 3×400 VAC / 50 Hz grid. (See Sec. 6.3.)

REQ 24: The CHPS shall be powered from the standard 3×400 VAC / 50 Hz grid. (See Sec. 6.3.)

REQ 25: A current and voltage measurement shall be included within each power supply.

REQ 26: Both current and voltage measurements on MSP, BPS and APS shall be located prior to the supply line to the gyrotron (high voltage side not the grounded side).

The Seller’s scope is for a power supply set for a single gyrotron, but the topology is to be compliant for a future addition of a second gyrotron, and matching BPS, APS, and CHPS.

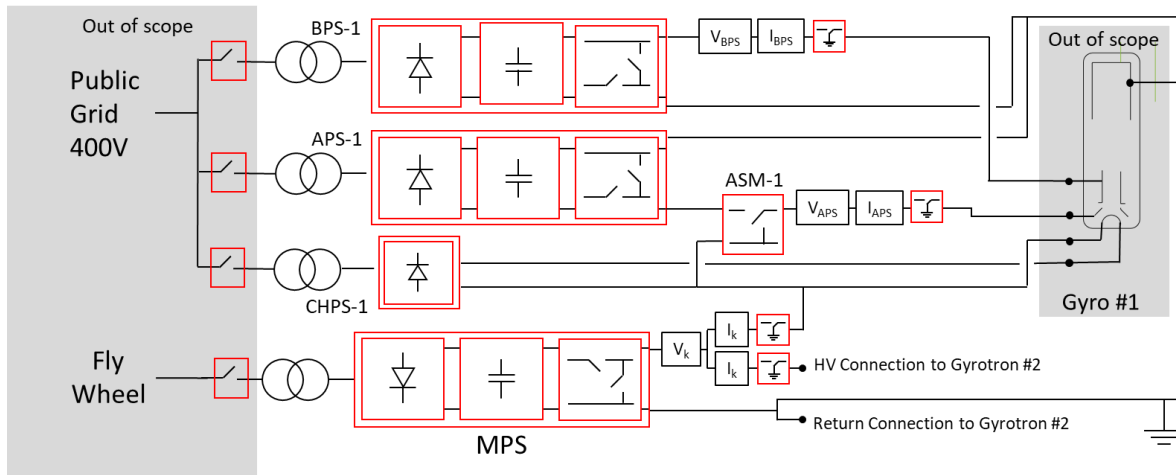

Figure 9: Topology of the HV PS system with the MPS supplying the cathode voltage and current to two gyrotrons, along with one BPS, one APS, and one CHPS. The items in grey are not included in the scope.

REQ 27: The HV PS system, cabling, and snubber unit shall be compatible with the gyrotron, which is a vacuum tube with a typical I-V curve as illustrated in Figure 2.

REQ 28: The HV PS system shall be compatible with the gyrotron capacitance, with typical capacitance values provided in Table 9.

ID	Connections	Capacitance	Comment
T9-01	Body to Collector, C_{bc}	1370 pF	
T9-02	Cathode to Collector, C_{kc}	1260 pF	
T9-03	Cathode to Body, C_{kb}	660 pF	
T9-04	Anode to Collector, C_{ac}	700 pF	
T9-05	Anode to Body, C_{ab}	460 pF	
T9-06	Anode to Cathode, C_{ak}	480 pF	

Table 9: Typical capacitances between the gyrotron connections, note that all values exclude the cable capacitance.

REQ 29: The HV PS system shall include hardware or software protective elements that ensure that, under fault-free operation, it is not possible to reach or exceed the maximum voltages between individual electrodes of the gyrotron. The maximum DC voltage values between the individual parts of the gyrotron are given in Table 10.

ID	Connections	Maximum DC voltage	Comment
T10-01	Cathode to Collector	-65 kV	Collector is grounded
T10-02	Anode to Collector	-65 kV	
T10-03	Anode to Cathode	+60kV	
T10-04	Body to Cathode	+90 kV	
T10-05	Body to Collector	+35 kV	

Table 10: Maximum allowable voltages in the gyrotron.

5.1.3. Parameters definition

Safe operation of the gyrotron is strongly dependent on the control of the applied voltages. This section defines the variable parameters specific to the gyrotron operation.

a) Parameters of the ramp up/down stage of the output voltage:

Switch-on/switch-off time: Is the time period including both voltage ramp-up/down time and voltage settling time, before the voltage has completely settled after the ramp up/down. This parameter applies only to the turn on/off event.

Voltage overshoot/undershoot: Is defined as the difference between the peak (maximum/minimum) and the target voltage after the ramp-up/down. The voltage overshoot is illustrated in Figure 10, with the nominal voltage measured once the voltage has completely settled. This parameter applies only during the turn on/turn-off period defined by the Switch-on/Switch-off time parameter.

b) Parameters of the steady state stage of the output voltage:

Ramp speed: Is defined as the rate at which the voltage increases or decreases, in units of kV/ms, during operation, i.e. after the initial ramp-up and before the final ramp-down.

Voltage ripple: Is the +/- maximum instantaneous voltage variance from the target voltage. The voltage ripple is also defined in Figure 10, and measured when the voltage has settled after the overshoot period.

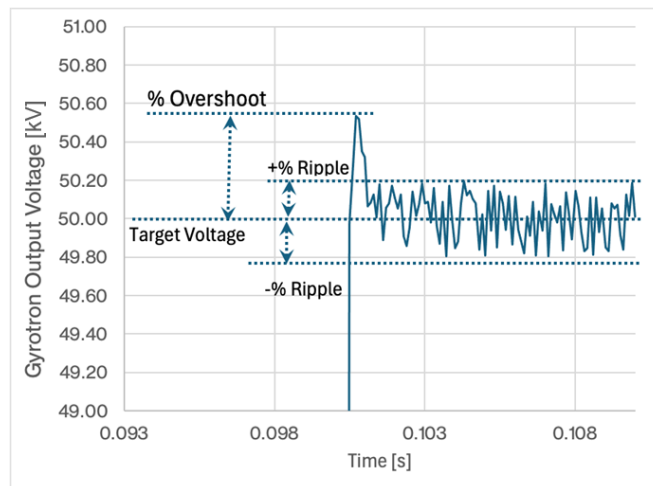

Figure 10: Definition of the voltage overshoot and ripple.

Voltage setability: Is defined as the smallest controllable step in the output voltage, as illustrated in Figure 11.

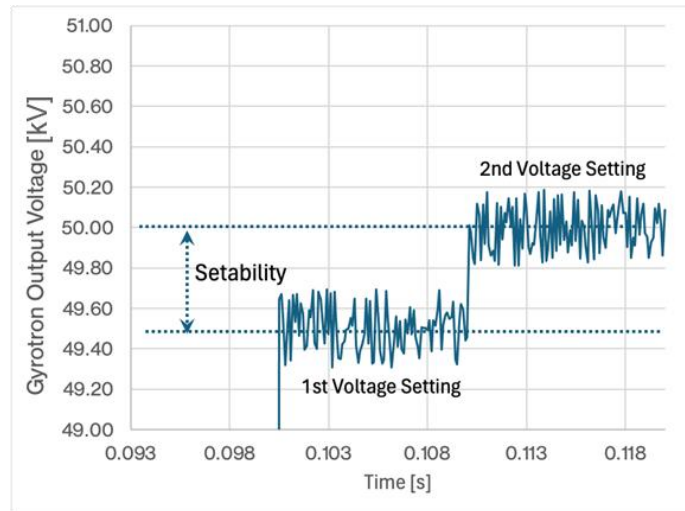

Figure 11: Definition of voltage setability, which corresponds to the minimum controllable step in output voltage.

Voltage reproducibility: Is the +/- difference between the shot-to-shot variation relative to the multi-shot (>10 shots) average, as illustrated in Figure 12a. This can be thought of as: if the same voltage is requested several times, how consistent the achieved voltage is.

Voltage accuracy: Is defined as the difference between the target voltage and the average measured voltage over multi-shot (≥ 10) average, as illustrated in Figure 12b. This can be thought of as: if a target voltage is requested, how close the achieved voltage is.

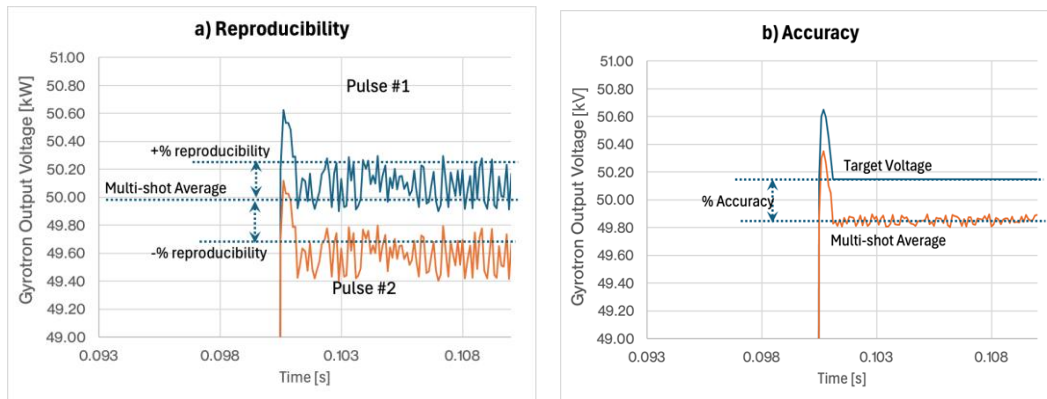

Figure 12: Definition of the voltage (a) reproducibility and (b) accuracy for the MPS, BPS, and APS.

Voltage stability: Is defined as the difference between the peak (maximum/minimum) and the target voltage caused by a transition from no-load to load or load to no-load. This parameter applies only during the period defined by the Voltage settling time parameter.

Voltage settling time: Is defined as the time period during which the voltage deviation from the target voltage, caused by a no-load to load or load to no-load transition, is allowed in accordance with the Voltage stability parameter definition.

5.1.4. Shutdown and shutdown signals

REQ 30: MPS, BPS, and APS shall be capable of a fast shutdown for all overcurrent, overvoltage and fast fault events.

REQ 31: MPS, BPS, and APS shall be able to receive internal and external shutdown signals. The shutdown signal may be provided by the ECRH control system, the Tokamak control system, another system functionally associated with the operation of the gyrotron, or directly by sensors.

REQ 32: MPS, BPS, and APS shall be able to receive internal and external shutdown signals from the other power supplies within the HV PS system.

REQ 33: The shutdown signal shall be transmitted via optical fibre and connected to the HV PS using an appropriate connector.

REQ 34: The shutdown signal shall be fail-safe, with an active signal required to allow operation of any HV PS subsystem. Note that this implies the interlock signal is “on” for safe operation; in the event of failure, the signal turns “off”, which is interpreted by the control system as a fault and prevents operation, thus achieving a “fail-safe” condition.

REQ 35: The Seller is responsible for the design and implementation of the internal shutdown signals, and the proper design shall be approved at the DR.

REQ 36: MPS, BPS, and APS shall be capable of shutdown time as specified in Table 11. Shutdown time is defined as the time it takes from the fault detection / receiving shutdown signal to the moment when the output voltage of the power supply falls below 10% of its nominal value, see Figure 13.

ID	Shutdown type	Shutdown Event	Shutdown Time	Description
T11-01	FAST	Internal shutdown signal: electrical arc / overcurrent / overvoltage	$\leq 10\mu\text{s}$	Required when any of the HV PS detects an arc, overcurrent / overvoltage condition
T11-02	FAST	External shutdown signal	$\leq 10\mu\text{s}$	Required when an external system demands immediate interruption of high voltage or microwave generation to protect either the gyrotron, transmission component downstream, or personnel and property.
T11-03	STANDARD	Standard	$\leq 200\text{ms}$	The nominal turn-off cycle from either an internal or external signal generator.

Table 11: Description of the types of shutdown speeds associated with the turn-off of the HV PS system.

REQ 37: The maximum overcurrent or overvoltage detection time shall be 2 μs prior to the shutdown time.

REQ 38: MPS, BPS, and APS shall be switched off (in all turn-off sequences) in such a way that the maximum arc-dissipated energy from each HV PS is less than 10 J into the gyrotron, assuming an arc voltage of 100 V.

REQ 39: The failure of any power supply to operate shall prevent the other power supplies from operating.

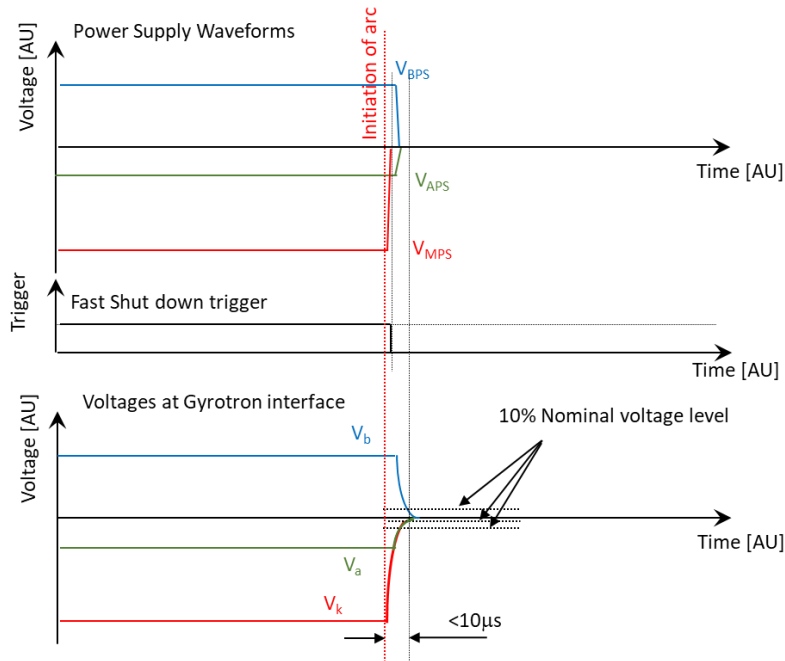

Figure 13: Example of a fast shutdown sequence of the MPS, BPS(s), and APS(s). The voltages at the gyrotron interface shall achieve $\leq 10\%$ of the nominal voltage within $10 \mu\text{s}$ of the initiation of the arc. Note that this includes the delay of the fault signal transmission. The example here is for an overcurrent in the MPS, but is applicable for an overcurrent in the BPS and APS.

5.1.5. Control system

REQ 40: The Seller shall deliver a control system that is capable to control entire HV PS system and all its components and enabling their operation.

REQ 41: The control system shall provide access to all information, measurements, and logs that unambiguously identify the state of the HV PS system and the cause of a fault in case of failure.

REQ 42: The control system shall provide clear information on whether the HV PS system is in a safe state for maintenance or for access to the restricted locations.

REQ 43: The control system shall allow the execution of a self-test on request to check that the HV PS system works and is ready for operation, e.g. check of the communication, input power, closed racks doors, and temperatures.

REQ 44: A human-machine interface (HMI) shall be delivered as part of the scope, providing full control of the HV PS system and access to all functions, capabilities, information, and data of the system. It shall be used for commissioning and maintenance.

REQ 45: The delivery shall include a user guide and personnel training for the control system.

REQ 46: The control system shall provide an interface for remote control that allows full control of the system and access to all functions, capabilities, information, and data of the system.

REQ 47: The Seller shall deliver interface documentation in English a full featured and well-documented application programming interface (API) preferably for a Linux operating system, and support for integration into Tokamak control system.

REQ 48: The API shall provide parameter's checks so that parameter settings outside the defined ranges or operable limits are rejected.

REQ 49: If the use of the API requires a license, a license valid for at least 10 years should be included as a part of the delivery.

REQ 50: The physical connection to the Tokamak control system shall be realized over an optical link.

REQ 51: The control system shall allow the synchronization of the time, and sampling frequency with the Tokamak control system. (The Buyer can provide a PTP protocol-based clock for time synchronization and a stable 10 MHz frequency source).

REQ 52: The control system shall accept the trigger signal (optical or software), to mark the start of the operation.

REQ 53: The control system shall accept the power off signal (optical or software) to mark the switch of the system to the safe state.

REQ 54: The control system overall latency for real-time operation, including the communication with the Tokamak control system, should be lower than one cycle of the internal control period.

REQ 55: All interface types and protocols for communication with the Tokamak control system, shall be negotiated and agreed upon by the Buyer.

REQ 56: The regulation error (output minus reference) should settle to zero within less than 50 μ s.

REQ 57: The HV PS system shall be capable of generating the pulses as for example shown in Figure 5 to Figure 7 using the internal generator as well as an external reference signal.

REQ 58: The HV PS system shall be capable of generating a complex pulse with power ramps, steps, and modulation as shown in Figure 8 using the external reference signal.

REQ 59: The -3 dB bandwidth for current and voltage measurements is defined by the following requirements: MPS: T12-14, BPS: T13-12, APS: T14-13. The control system must be capable of real-time transmission of voltage and current measurements to the Tokamak control system during the pulse with a -3 dB bandwidth of 100 kHz.

REQ EXT 1: The Seller shall propose a procedure describing how to proceed in the event of a hardware failure on which individual parts of the control system are running. Together with this procedure, the Seller shall provide, as part of the delivery, a backup of the software and firmware, enabling the Buyer to restore and commission the control system on new hardware in accordance with the implementation manual. The details shall be discussed and approved by the Buyer during the Design Review.

5.2. Main Power Supply (MPS)

REQ 60: The MPS shall comply with the technical requirements for the Main Power Supply as listed in Table 12.

REQ 61: The residual voltage between pulses shall be maintained at ≤ 1.0 kV.

REQ 62: At the end of an operating period, the output voltage connections shall be grounded to ensure personnel can safely approach either the gyrotron and/or the power supplies.

REQ 63: The MPS output voltage shall be controllable by the internal signal generator as well as an external reference signal for feedback control, with a latency (the delay between the reception of the reference trace to the output voltage response) not exceeding < 1 ms.

REQ 64: The MPS variation in latency between pulses shall not exceed < 0.1 ms.

REQ 65: The MPS shall be capable of both a latched (requiring a reset by the operator) and an automated reset (with a programmable delay from 0.1 to 0.5 s).

REQ 66: If the MPS is in the automated reset mode, the reset shall initiate a restart following a standard voltage ramp-up as defined in Figure 5.

REQ 67: The MPS shall include the cable and snubber network as required to comply with the limits on the dissipated arc energy and shutdown time.

The MPS is expected to operate and be controllable over the full voltage range from 0 to V_k , however, two ranges of operation are specified. Output voltage parameters T12-07 to T12-11 are required only

within the fine (higher) operating voltage range. Fulfilling the output voltage parameters T12-07 to T12-11 within the coarse (lower) operating voltage range is not mandatory.

Note that high frequency modulation or voltage control is not required for the MPS, this is achieved via the APS or the Anode Switching Mechanism (ASM).

ID	Parameters	Value	Notes
T12-01	V_k nominal	-55 kV	
T12-02	I_k nominal	> 110 A	2 x 55 A
T12-03	Power Supply : Gyrotron ratio	1:2	MPS will feed two identical gyrotrons
T12-04	V_k coarse range	0 to -30 kV	
T12-05	V_k fine range	-30 kV to -55 kV	
T12-06	Switch on/Switch-off time	< 10 ms	
T12-07	Max overshoot/undershoot	$\leq \pm 1100$ V	$\leq \pm 2$ % @ 55 kV
T12-08	V_k accuracy	$\leq \pm 330$ V	$\leq \pm 0.6$ % @ 55 kV
T12-09	V_k reproducibility	$\leq \pm 220$ V	$\leq \pm 0.4$ % @ 55 kV
T12-10	V_k setability	$\leq \pm 220$ V	$\leq \pm 0.4$ % @ 55 kV
T12-11	V_k ripple	$\leq \pm 220$ V	$\leq \pm 0.4$ % @ 55 kV
T12-12	Ramp speed	$dV/dt > 1$ kV/ms	
T12-13	Measurement accuracy of voltage / current @ DC	<0.1% / <0.2%	DC accuracy
T12-14	Measurement bandwidth (-3 dB)	2 MHz	The bandwidth is defined by -3 dB loss.
T12-15	Pulse Length (load)	15 sec	
T12-16	Pulse Length (load + no-load)	16 sec	
T12-17	Duty Cycle	up to 2%	
T12-18	Energy in an Arc event	< 10 J	This assumes 100 V arc voltage.
T12-19	Fast Shutdown time	< 10 μ s	From fault detection to less than 5.5 kV.
T12-20	MPS efficiency	> 90%	steady state operation and nominal parameters
T12-21	Voltage Stability (no-load to load events & load to no-load events)	$\leq \pm 1100$ V	$\leq \pm 2$ % @ 55 kV
T12-22	Voltage Settling time (no-load to load & load to no-load events)	< 50 μ s	

Table 12: Required parameters for the MPS. All voltage values are measured relative to the ground potential (gyrotron collector potential V_c).

5.3. Body Power Supply (BPS)

REQ 68: The BPS shall comply with the technical requirements listed in Table 13.

REQ 69: The residual voltage between pulses shall be maintained at ≤ 1.0 kV.

REQ 70: At the end of an operating period, the output voltage connections shall be grounded to ensure personnel can safely approach either the gyrotron and/or power supplies.

REQ 71: The BPS output voltage shall be controllable by an internal signal generator as well as an external reference signal with a latency not exceeding 1 ms.

REQ 72: The BPS variation in latency between pulses shall not exceed <0.1 ms.

REQ 73: The BPS shall be capable of both a latched (requiring a reset by the operator) and an automated reset (with a programmable delay from 0.1 to 0.5 s). Reset shall only occur if all interlocks and protection conditions are satisfied.

REQ 74: If the BPS is in the automated reset mode, the reset shall initiate a restart following a standard voltage ramp-up as defined in Figure 5. Reset shall only occur if all interlocks and protection conditions are satisfied.

REQ 75: Even though this contract is for the delivery of one Body power supply, the control logic and design shall be compatible with a later addition of a second Body power supply of the same type.

REQ 76: Each Body Power Supply shall be independently controllable.

REQ 77: The Body Power Supply shall include the HV DC cable and snubber network as required to comply with the limits on the dissipated arc energy and shutdown time.

The Body Power Supply is expected to operate with fine controllability over the full voltage range from 0 to V_b .

The nominal Body current is not expected to exceed the I_b nominal value, however, there are expected to be transients with the peak I_b value reaching the maximum as specified in Table 13.

Note that high frequency modulation or voltage control is not required for the BPS, as this is achieved via the APS or the Anode Switching Mechanism (ASM).

ID	Parameters	Value	Notes
T13-01	V_b nominal	33 kV	Referenced to ground
T13-02	I_b nominal	100 mA	
T13-03	I_b maximum	125 mA	
T13-04	Switch on/Switch-off time	< 10 ms	
T13-05	Max overshoot/undershoot	$\leq \pm 400$ V	$\leq \pm 1$ % @ 40 kV
T13-06	V_b accuracy	$\leq \pm 120$ V	$\leq \pm 0.3$ % @ 40 kV
T13-07	V_b reproducibility	$\leq \pm 120$ V	$\leq \pm 0.3$ % @ 40 kV
T13-08	V_b setability	$\leq \pm 120$ V	$\leq \pm 0.3$ % @ 40 kV
T13-09	V_b ripple	$\leq \pm 120$ V	$\leq \pm 0.3$ % @ 40 kV
T13-10	Ramp speed	$dV/dt > 1$ kV/ms	
T13-11	Measurement accuracy of voltage / current @ DC	0.1% / 0.2%	
T13-12	Measurement bandwidth (-3 dB)	2 MHz	The bandwidth is defined by -3 dB loss.
T13-13	Pulse Length (load)	15 sec	
T13-14	Pulse Length (load + no-load)	16 sec	
T13-15	Duty Cycle	up to 2%	
T13-16	Energy in an Arc event	< 10 J	This assumes 100 V arc voltage.
T13-17	BPS efficiency	> 75%	
T13-18	Voltage Stability (no-load to load events & load to no-load events)	$\leq \pm 400$ V	$\leq \pm 1$ % @ 40 kV
T13-19	Voltage Settling time (no-load to load & load to no-load events)	< 50 μ s	

Table 13: Required parameters for the BPS.

Note that the limits for parameters T13-05 to T13-09 and T13-18 are not relative to the nominal voltage V_b .

5.4. Anode Power Supply (APS)

REQ 78: The APS shall comply with the technical requirements listed in Table 14.

REQ 79: The APS shall include a fast switching circuit that can connect the Anode feeder line to either the MPS output voltage or the APS output voltage, consistent with Figure 14 and the specifications of Table 14.

REQ 80: The residual voltage between pulses shall be maintained at ≤ 1.0 kV.

REQ 81: At the end of an operating period, the output voltage connections shall be grounded to ensure personnel can safely approach either the gyrotron and/or power supplies.

REQ 82: The APS output voltage shall be controllable by an internal signal generator as well as an external reference signal for feedback control with a latency not exceeding 1 ms.

REQ 83: The APS variation in latency between pulses shall not exceed < 0.1 ms.

REQ 84: The ASM shall be controllable by an internal signal generator as well as an external reference signal for feedback control with a latency not exceeding 0.01 ms (10 μ s)

REQ 85: The APS shall be capable of both a latched (requiring a reset by the operator) and an automated reset (with a programmable delay from 0.1 to 0.5 s).

REQ 86: If the APS is in the automated reset mode, the reset shall initiate a restart following a standard voltage ramp-up as defined in Figure 5.

REQ 87: Even though this contract is for the delivery of one Anode Power Supply, the control logic and design shall be compatible with a later addition of a second Anode Power Supply of the same type.

REQ 88: Each Anode Power Supply and Anode Switching Mechanism shall be independently controllable.

REQ 89: The APS shall include the HV DC cable and snubber network as required to comply with the limits on the dissipated arc energy and shutdown time.

The Anode power supply is expected to operate with fine controllability over the full voltage range from 0 to V_a .

The nominal Anode current is not expected to exceed the I_a nominal value, however, there are expected to be transients with the peak I_a value reaching the maximum as specified in Table 14.

Note that the listed values of nominal and maximal current I_a apply only for the Anode of the gyrotron itself. Specific designs may include bypass resistors into the APS assembly and thus increasing the overall APS current significantly.

ID	Parameters	Value	Notes
T14-01	V_a nominal, if connected to Collector potential	-30 kV	Referenced to ground
T14-02	V_a nominal, if connected to Cathode potential	50 kV	Referenced to Cathode
T14-03	I_a nominal	10 mA	Current to Anode only
T14-04	I_a maximum	100 mA	Current to Anode only
T14-05	Switch on/Switch-off time	< 10 ms	
T14-06	Max overshoot/undershoot	$\leq \pm 500$ V	± 1 % @ 50 kV
T14-07	V_a accuracy	$\leq \pm 150$ V	$\leq \pm 0.3$ % @ 50 kV
T14-08	V_a reproducibility	$\leq \pm 150$ V	$\leq \pm 0.3$ % @ 50 kV
T14-09	V_a setability	$\leq \pm 150$ V	$\leq \pm 0.3$ % @ 50 kV
T14-10	V_a ripple	$\leq \pm 150$ V	$\leq \pm 0.3$ % @ 50 kV
T14-11	Ramp speed	$dV/dt > 1$ kV/ms	
T14-12	Measurement accuracy of voltage / current @ DC	0.1% / 0.2%	

T14-13	Measurement bandwidth (-3 dB)	2 MHz	The bandwidth is defined by -3 dB loss.
T14-14	Pulse Length (load)	15 sec	
T14-15	Pulse Length (load + no-load)	16 sec	
T14-16	Duty Cycle	up to 2%	
T14-17	Energy in an Arc event	< 10 J	This assumes 100V arc voltage.
T14-18	APS efficiency	> 75%	
T14-19	Voltage Stability (no-load to load events & load to no-load events)	$\leq \pm 500$ V	± 1 % @ 50 kV
T14-20	Voltage Settling time (no-load to load events)	< 20 μ s	
T14-21	Voltage Settling time (load to no-load events)	< 50 μ s	

Table 14: Required parameters for the APS.

REQ 90: The ASM will be capable of up to 1 kHz modulation with the modulation being defined either locally or via an external trigger.

REQ 91: The modulation ramp-up time (t_r) and modulation ramp-down time (t_f) shall be compatible with the 1 kHz modulation and shall achieve an 80% voltage change (from 10% to 90%) over ≤ 40 μ s as illustrated in Figure 14.

REQ 92: The delay in initiating the ramp (t_d) shall not exceed 40 μ s.

REQ 93: The duty cycle of the modulation shall be variable from 10% to 90%.

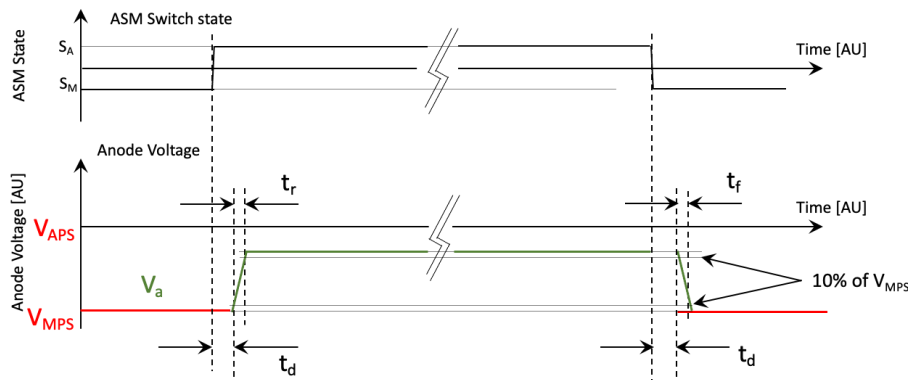

Figure 14: The Anode Voltage (V_a) during the switching sequence of the ASM. The switching speed will be up to 1 kHz, with the delay time (t_d), ramp-up time (t_r) and ramp-down time (t_f) not exceeding 40 μ s.

ID	Variable	Value	Comment
T15-01	Modulation ramp-up time (t_r)	≤ 40 μ s	Switching from V_{MPS} to V_{APS}
T15-02	Modulation ramp-down time (t_f)	≤ 40 μ s	Switching from V_{APS} to V_{MPS}
T15-03	Delay in initiating the ramp (t_d)	≤ 40 μ s	
T15-04	Modulation duty cycle range	10% to 90%	
T15-05	Modulation frequency range	0–1 kHz	

Table 15: Definition of the variables that determine the relevant time constants of the ASM.

5.5. Cathode Heater Power Supply (CHPS)

The purpose of the Cathode Heater Power Supply is to provide the electrical power needed to heat the filament located inside the cathode. Therefore, it must be a floating (isolated) power source that follows the cathode potential.

REQ 94: Cathode Heater Power Supply output voltage shall range from 0 to 40 V DC or AC (RMS).

REQ 95: Cathode Heater Power Supply output current shall range from 0 to 12 A.

REQ 96: Cathode Heater Power Supply should be remotely controllable, and it shall communicate with the HV PS control system.

REQ 97: The Seller shall design an adequate isolation transformer and a protective rack, both the transformer and the rack are part of the delivery. The Seller shall consider the design and both the nominal and operating parameters of the MPS.

5.6. Transitions between Load and No-Load States

The use of the Anode Switching Mechanism avoids having stringent modulation requirements on the fast control of the MPS, BPS and APS. However, all of these power supplies are required to maintain the voltage stability requirements during the fast switching between load and no-load conditions, as illustrated in Figure 15 and Figure 16.

REQ 98: During ASM switching between the cathode and anode voltages, MPS, BPS, and APS shall be compliant with interchanging between no-load and load conditions in Table 12, Table 13, and Table 14.

REQ 99: The perturbation to the MPS applied voltage should occur only during Voltage Stability Settling time and should remain within the limits defined by Voltage stability parameters in Table 12. The graphical representation of the requirement is shown in Figure 15.

REQ 100: The perturbation to the BPS applied voltage should occur only during Voltage Stability Settling time and should remain within the limits defined by Voltage stability parameters in Table 13. The graphical representation of the requirement is shown in Figure 15.

REQ 101: The perturbation to the APS applied voltage should occur only during Voltage Stability Settling time and should remain within the limits defined by Voltage stability parameters in Table 14. The graphical representation of the requirement is shown in Figure 16.

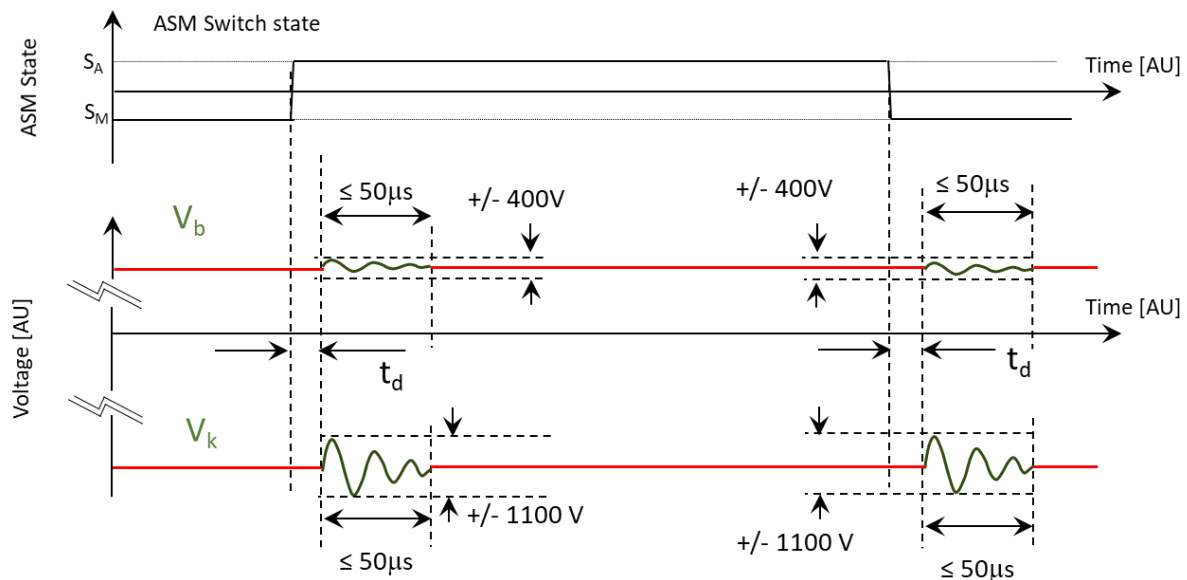

Figure 15: The allowable variance in the applied Main and Body voltages at the gyrotron interface during the ASM switching between the Anode and Main Power Supply voltages. Note that t_d is the ASM delay time as defined in Figure 14 and Table 15.

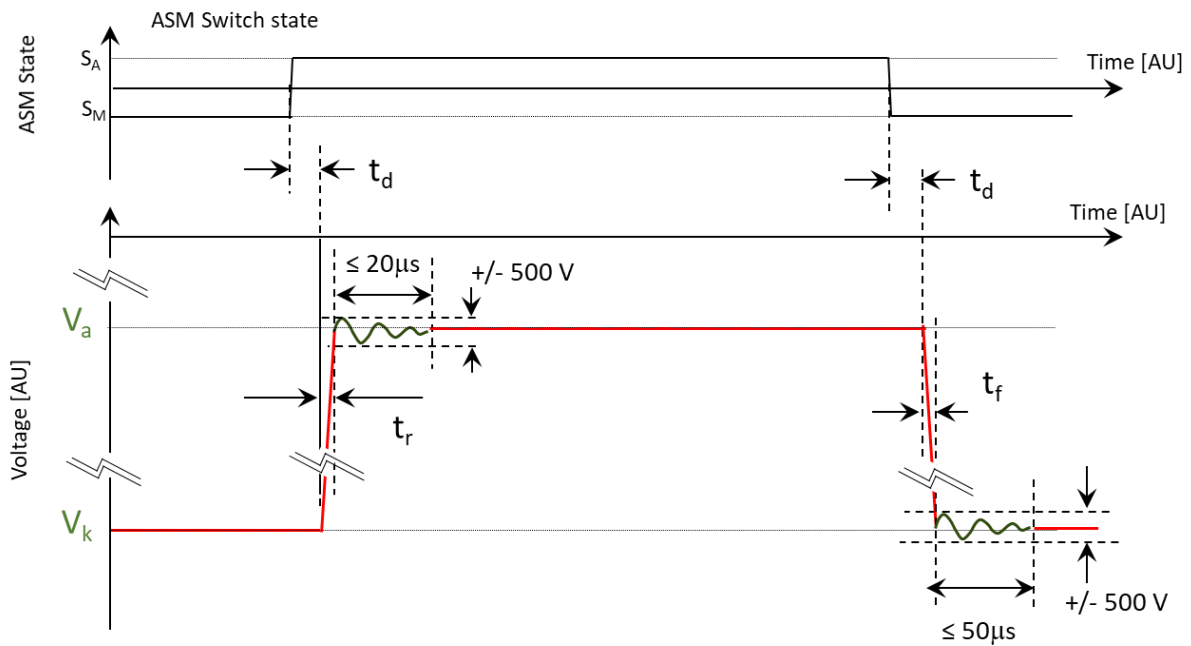

Figure 16: The allowed overshoot/undershoot of Anode voltage at the gyrotron interface during the ASM switching between the Anode and Main Power Supply voltages. Note that t_d , t_r , and t_f are defined in Figure 14 and Table 15.

5.7. Safety Switches

REQ 102: The Seller shall include dual purpose (isolation and safety) switches at the output of the MPS (2 switches), one BPS, and one APS (as illustrated in Figure 17) that can disconnect a gyrotron in ≤ 2 s.

REQ 103: The Seller shall include switching mechanisms to enable switching of the output connection of MPS, BPS, and APS between the gyrotron and their respective dummy loads (as illustrated in Figure 17). These switching mechanisms shall enable connection of the other (i.e. non-operational) output to the ground.

Note that grounding of the non-operational output of the MPS switching mechanism is essential for testing of the ASM.

REQ 104: Design of the switching mechanisms enabling connection of the Power Supplies to their respective dummy loads shall be proposed by the Seller and agreed upon by the Buyer during the Design Review. Operation of these switching mechanisms should be user friendly.

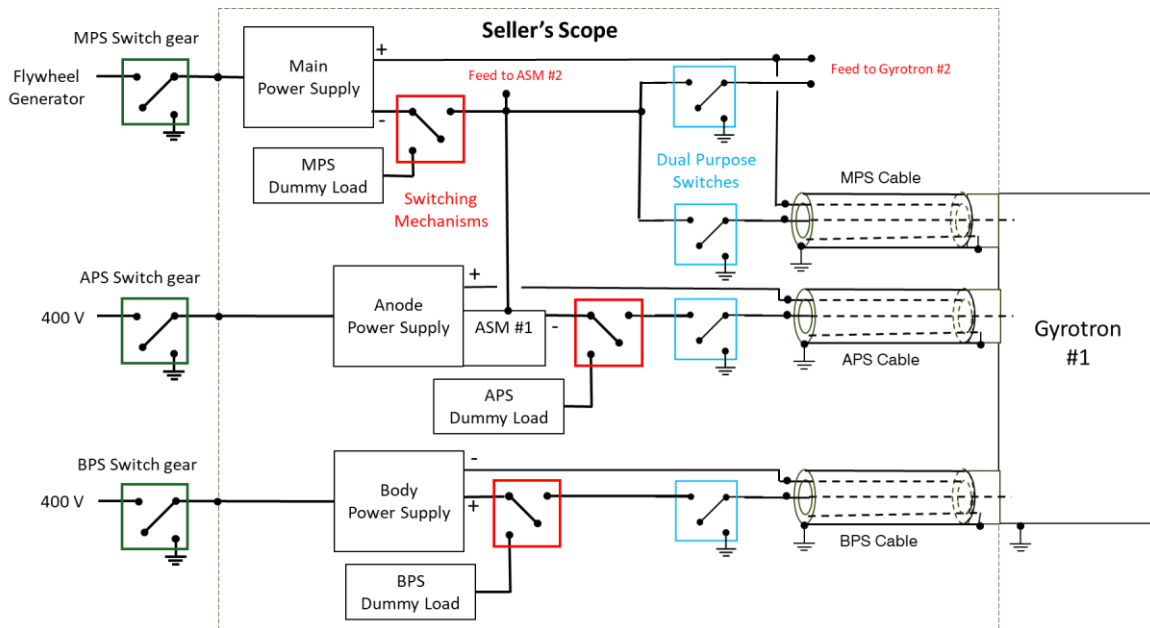

Figure 17: The switching configuration used to deviate the power to dummy loads. As well as, the switches used to isolate the input line voltage and the voltage to the gyrotrons.

Note that the input switchgear for MPS, BPS, and APS is not part of the Seller's scope and will be provided by the Buyer.

5.8. Cabling and Routing

REQ 105: The Seller can use a crowbar in the circuit, which will be installed between the HV PS and the gyrotron. In case the crowbar is installed in the vicinity of the gyrotron, such installation shall be subject to the Buyer's approval.

REQ 106: The Seller can use a snubber in the circuit, which will be installed between the HV PS and the gyrotron, in order to prevent current spikes during transient events and thereby limit the power delivered during an arc. In case the snubber is installed in the vicinity of the gyrotron, such installation shall be subject to the Buyer's approval.

REQ 107: The design of the snubbers, crowbars, and/or any other additional circuitry affecting the behavior of HV PS, shall not degrade or otherwise negatively influence the required waveforms. The Seller shall propose the parameters of the circuits and submit them to the Buyer for approval during the Design Review. Any changes to topology, component values, or parameters are subject to the same approval process.

REQ 108: Triaxial or coaxial DC HV cables shall be used for interconnecting the individual HV PS components and for connecting the HV PS to the gyrotron.

REQ 109: The Seller shall design the cable routing and connections for approval at the Design Review (DR) with due consideration to minimizing electromagnetic compatibility (EMC) issues. The use of coaxial or triaxial cables for individual connections shall be discussed in advance with the Buyer and subsequently approved.

The basis for the discussion with the Buyer shall be an electrical wiring diagram, including the actual grounding arrangement.

REQ 110: As part of the price offer (see Annex No. 3 - Price Schedule and Deliverables_HVPS), the Seller shall provide a cost estimation for the cables as follows:

Triaxial cable: An estimated cost for total length of 210 m.

Coaxial cable: An estimated cost for total length of 170 m.

Note that either all connections in the system will be implemented using triaxial cables, or part of the interconnections will be implemented using coaxial cables and the remaining connections will be implemented using triaxial cables. In this case, the total ordered quantity of triaxial cables will be reduced accordingly.

REQ 111: The Seller shall prepare a proposal of the cable routing and layout of the HV PS components to enable determination of the actual cable lengths required. Subsequently, the Buyer orders from the Seller the corresponding quantities of coaxial and triaxial cables (see Contract Conditions).

REQ EXT 2: For the connection to the gyrotron, the Seller shall use appropriate oil-sealed connectors.

REQ EXT 3: As part of the delivery of Item No. 1 – High Voltage Power Supplies (HV PS) from Table 7, the Seller shall also provide the following cables:

- Cables for grounding of the switches, racks, or individual components of the HV Power Supply (HV PS).
- Power supply cables for the HV PS.
- The cable between the APS and ASM, if required by the power supply design.
- Interconnection cables between the individual components of the MPS, APS, BPS, and CHPS.

5.9. Dummy Loads

5.9.1. MPS Load

REQ 112: The Seller shall provide an MPS dummy load (MPS-DL) suitably rated for commissioning and testing of the MPS.

REQ 113: The MPS-DL shall be used for the testing of the MPS at its full voltage and current rating defined in Table 12, and pulse length 1 s.

REQ 114: The MPS-DL should mimic 2 gyrotrons connected in parallel, i.e. double the gyrotron capacitance (see Table 9), resistance of two gyrotrons defined as V_k nominal / I_k nominal, and double the capacitance from the HV cabling.

REQ 115: The MPS-DL should be air cooled and compatible with a 2% operating duty cycle. If forced air cooling is required, the Seller shall provide the required ventilation system as part of the MPS-DL.

5.9.2. BPS Load

REQ 116: The Seller shall provide a BPS dummy load (BPS-DL) suitably rated for commissioning and testing of the BPS.

REQ 117: The BPS-DL shall be used for the testing of the BPS at its full voltage, current, and pulse length rating as defined in Table 13.

REQ 118: The BPS-DL should mimic the gyrotron capacitance (see Table 9), resistance defined as V_b nominal / I_b nominal, and capacitance from the HV cabling.

REQ 119: The BPS-DL should be air cooled and compatible with a 2% operating duty cycle. If forced air cooling is required, the Seller shall provide the required ventilation system as part of the BPS-DL.

5.9.3. APS Load

REQ 120: The Seller shall provide an APS dummy load (APS-DL) suitably rated for commissioning and testing of the APS.

REQ 121: The APS-DL shall be used for the testing of the APS at its full voltage, current, and pulse length rating as defined in Table 14.

REQ 122: The APS-DL should mimic the gyrotron capacitance (see Table 9), resistance defined as V_a nominal / I_a nominal, and capacitance from the HV cabling.

REQ 123: The APS-DL should be air cooled and compatible with a 2% operating duty cycle. If forced air cooling is required, the Seller shall provide the required ventilation system as part of the BPS-DL.

5.10. Additional Requirements

5.10.1. Lifetime

REQ 124: The HV PS should have a lifetime exceeding 50,000 pulses at nominal parameters and a maximum pulse length of 15 s. Modulation provided by the ASM may be present in every pulse throughout the entire lifetime. Therefore, for the purpose of lifetime evaluation, the pulse with the worst load conditions should be considered.

REQ 125: The CHPS should be capable of continuous operation for at least 16 hours per day. The lifetime of the CHPS should be at least 4,500 days.

REQ 126: The Seller shall evaluate the thermal load of the semiconductor components of the HV PS and submit it to the Buyer for approval during the Design Review.

REQ 127: The Seller should evaluate the lifetime of the most thermally stressed semiconductor components of the HV PS during the Design Review.

REQ 128: The HV PS reliability at full specification (power and pulse length) should be >95%.

REQ 129: The Seller should use only such hardware and software components for control system and monitoring that, at the time of assembly, have a demonstrable continuation of support from their original manufacturer. This support shall include, at minimum, the availability of firmware/software updates, service documentation, component support in the currently supported official development tools, and spare parts for a reasonable period within the device's lifecycle.

Upon request, the Seller shall provide evidence or a declaration confirming the validity and long-term supportability of all components used.

REQ 130: All power semiconductors selected for HV PS should have an active production status, with no End-of-Life notifications issued, and should be included in the manufacturer's current long-term production roadmap.

Upon request, the Seller shall provide documentation or statement confirming that the selected power semiconductor devices remain in ongoing production and are not scheduled for discontinuation.

5.10.2. Monitoring and protection

REQ 131: The Seller shall prepare a system for monitoring the temperature of the relevant parts of the HV PS and associated ancillary systems. The data shall be processed by the control system. The Seller shall submit to the Buyer, for approval during the Design Review, a description of the system as well as the limits and interlock actions for each measurement point.

5.10.3. Enclosures and Fences

REQ 132: The BPS and APS should be installed within separate racks. The Seller shall be responsible for providing these dedicated HV enclosures, and implementing all necessary safety interlocks associated with these areas.

Note: The fencing shall restrict and control access to the MPS, BPS and APS area in accordance with the safety requirements for high-voltage equipment. The delivery of the fences is the responsibility of the Buyer, following mutual agreement between the parties.

5.10.4. Other

REQ 133: Any part of the HV power supply system that is built from individual modules (primarily, but not limited to, the MPS) should be capable of continued operation, starting from the next pulse after failure detection, with reduced parameters when several numbers of the modules are non-functional. Failure of a single module, or a small number of modules, should not cause the individual power supply completely non-functional. Operation of the Power Supplies in this limited mode may require service intervention by the Buyer and/or specific actions within the control system.

REQ 134: In the event of a short circuit between the gyrotron electrodes, the MPS, APS, and/or BPS become electrically interconnected. This can lead to events including, but not limited to, full voltage V_k (nominal value -55 kV) being applied to the positive terminal of the BPS, or to the positive or negative terminal of the APS, acting as reverse voltage or overvoltage depending on the specific topology of the HV PS. These conditions will always cause an overcurrent and shall therefore result in a fast shutdown of MPS, APS, and BPS according to Section 5.1.4 (see Table 11). All power supplies shall withstand the applied voltages and currents under the respective worst-case scenarios.

6. Interface

6.1. HV grid / Flywheel Generator

REQ 135: Main Power Supply shall be supplied from an internal HV grid powered by flywheel generator with parameters summarized in this chapter.

REQ 136: Nominal voltage of the HV grid supplying MPS is 3×10.4 kV (line-to-line, RMS value).

REQ 137: During the HV PS operation, the instantaneous voltage of the HV grid supplying MPS is subject to “slow” changes caused by actual consumptions of other systems supplied from the HV grid. Maximal “slow” voltage deviations from the nominal value can reach up to -11% and $+13\%$. Standard HV grid voltage envelope during the tokamak pulse affected by the “slow” changes is shown in Figure 18 and Figure 19.

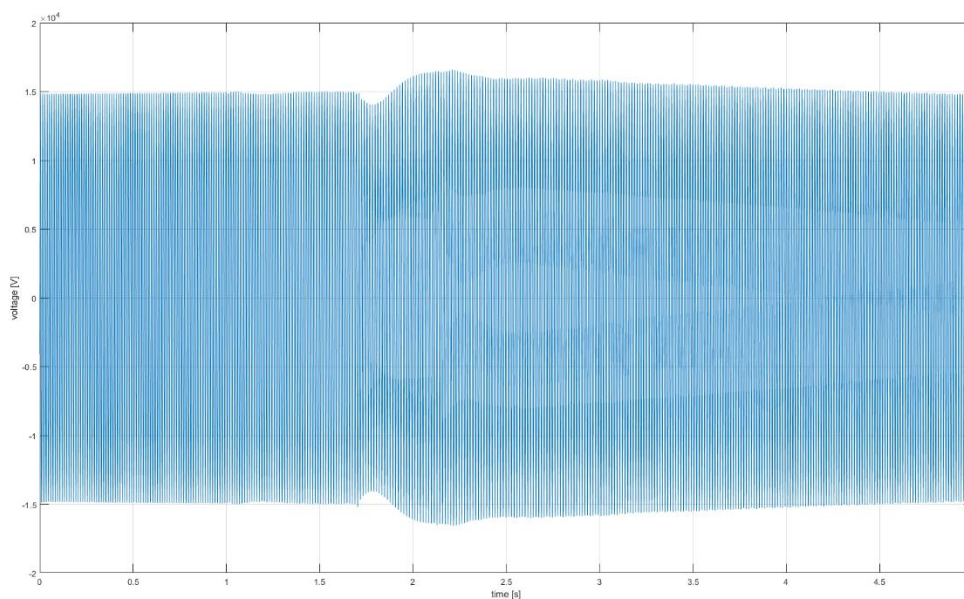

Figure 18: Standard waveform of HV grid powered by flywheel generator during the tokamak pulse: voltage envelope

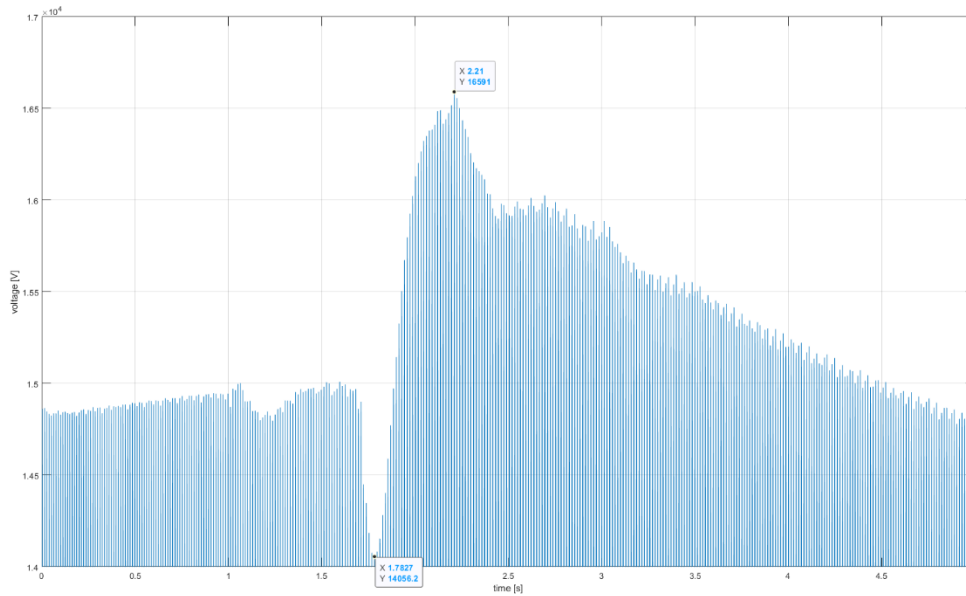

Figure 19: Standard waveform of HV grid powered by flywheel generator during the tokamak pulse: voltage envelope detail

REQ 138: During the HV PS operation, the instantaneous voltage of the HV grid supplying MPS is subject to “fast” changes (drops) caused by commutation of other systems supplied from the HV grid. Maximal “fast” voltage changes (drops) from the actual value (i.e. nominal value affected by „slow“ changes) can reach up to -42%, duration of these “fast” voltage changes (drops) can reach up to 500 μ s (i.e. before the voltage returns back to its actual value). Standard HV grid voltage waveform during a single period affected by “fast” changes (drops) is shown in Figure 20.

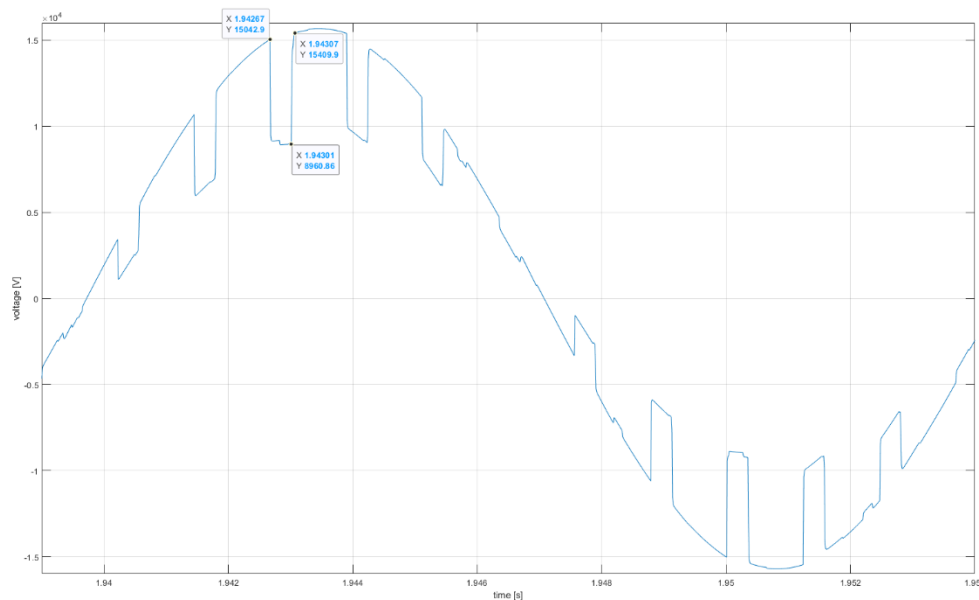

Figure 20: Standard waveform of HV grid powered by flywheel generator during the tokamak pulse: voltage single period detail

REQ 139: MPS shall be operational and fulfil all required parameters during entire duration when powered from the HV grid with individual line-to-line voltage waveforms presented in Annex CU_HEAT-02-01-02_PTD Technical Specification - Annex No. 2 - Waveform of HV grid.

REQ 140: Nominal frequency of the HV grid supplying MPS is 60 – 85 Hz. During the HV PS operation, the instantaneous frequency of the HV grid supplying MPS is changing and can reach any value within the specified range 60 – 85 Hz.

Note that during the tokamak pulse, the frequency of the HV grid supplying MPS is changing due to decrease of the rotational speed of the flywheel generator.

6.2. Gyrotron

The power supply assembly is envisioned to power two 1 MW triode gyrotrons each capable of operating up to 15 s. Although this procurement is for a single set of Anode and Body Power Supplies, the Main Power Supply shall be able to power two gyrotrons.

The Seller is responsible for the cabling up to the gyrotron assembly, with the connector type to be specified by the Buyer at the Kick-Off Meeting.

Each gyrotron will be capable of operating at more than one frequency, which will require the independent control of each Anode and Body Power Supply, as each frequency requires different voltage settings.

The electrical connections of the triode gyrotron are illustrated in Figure 4.

A typical voltage current curve of a triode gyrotron is shown in Figure 2.

The typical capacitances between the gyrotron connectors are provided in Table 9.

6.3. Low Voltage Network

REQ 141: Anode and Body Power Supplies, Cathode Heater Power Supply, and any ancillary systems shall be supplied from standard European Continental Grid: $3 \times 400 \text{ V} \pm 10\%$ (line-to-line, RMS value) / 50 Hz.

The Buyer will provide the Seller with access to switchboards in the ECRH building for connection of HV PS system components supplied from the Low Voltage Network.

7. Building constraints

7.1. Space constraints / layout

This section provides details on the specific space constraints within the ECRH building, with further schematics shown in the Annexes. Note that the floors are numbered 1 to 3, with 1 being at external ground level.

Components of the HV PS system can be lifted up via the crane through a hole in the floor, which reaches down to the first (external ground level) floor. Detail drawing is in CU_HEAT-02-01-02_PTD Technical Specification - Annex No. 1 - Building drawings.

BPS and APS will be located on the third floor of the building (see Figure 21); the dedicated area is $\sim 15.6 \times 6$ m and the maximum average load in this area is 350 kg/m^2 . The high voltage cables will reach the third floor from the first floor through two openings $\sim 1.5 \times 0.5$ m.

MPS will be located on the first floor of the building (see Figure 22); the dedicated area is $\sim 9.9 \times 6.9$ m, the maximum height being 3.5 m. The access to this area is through two doors 1.6 m wide and 2.7 m high.

REQ 142: The arrangement of racks, cabling, and individual components of the HV PS system shall be designed in such a way that power supplies in the same configuration can fit into the designated area for at least four (4) gyrotrons.

REQ 143: The Seller should make reasonable efforts to optimize the layout of individual components of the HV PS system so that the same area can accommodate power supplies in the same configuration for six (6) gyrotrons.

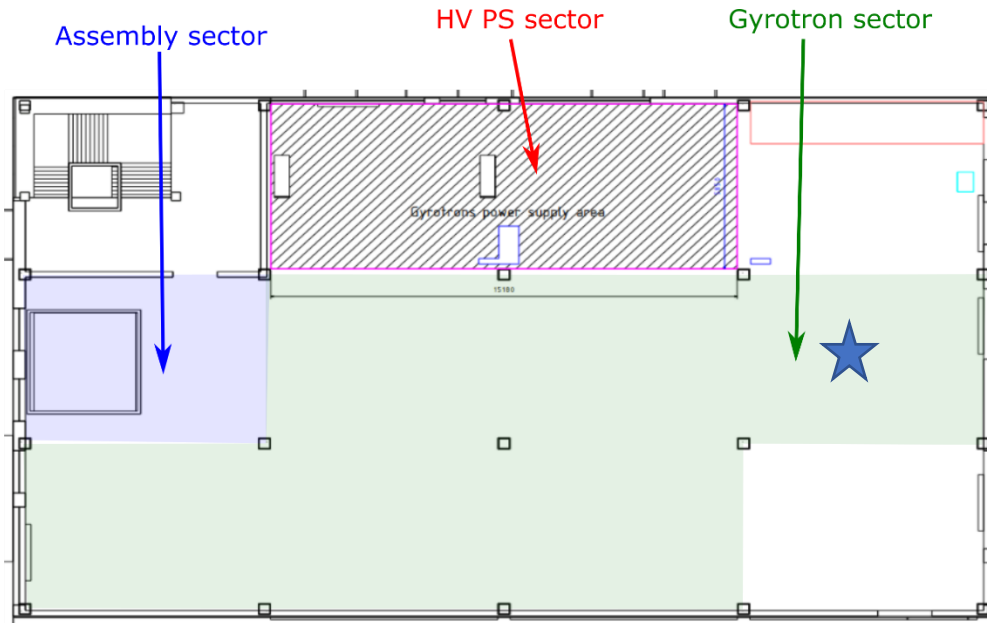

Figure 21: Layout of 3rd floor dedicated to ECRH – distribution into sectors according to purpose. The area inside the magenta box is dedicated to the HV PS. The star indicates the position of the gyrotron feed by the HV PS.

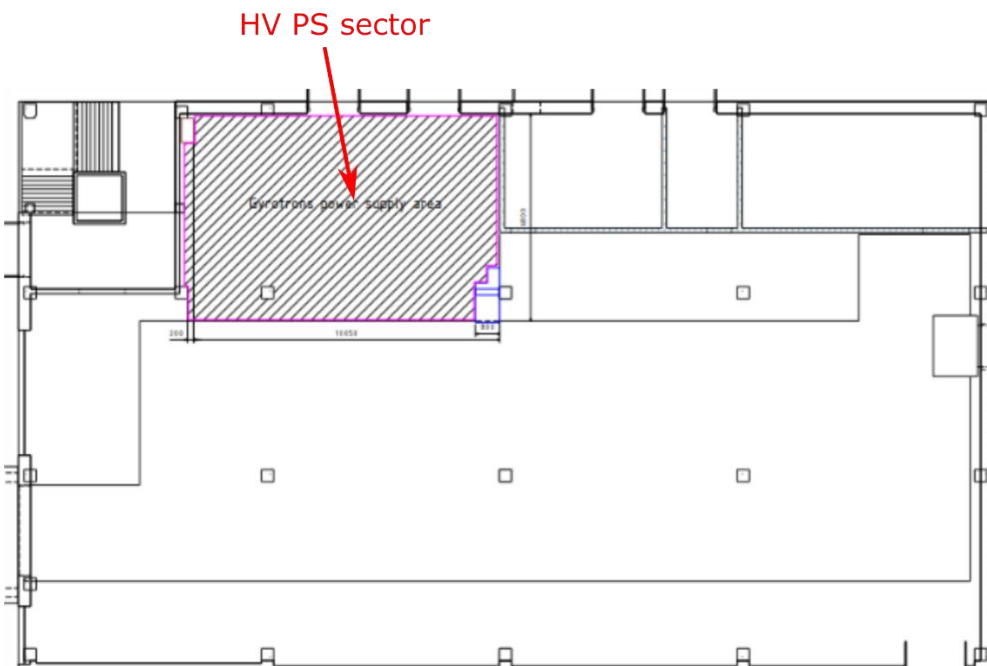

Figure 22: Layout of 1st floor – the area inside the magenta box is dedicated to the MPS

REQ 144: When designing the layout, the Seller shall ensure good and immediate access to all components of the HV power supplies that may require maintenance.

7.2. Load Constraints

The ECRH floor is divided into three sectors according to the maximum allowed average load (see Figure 23). The sector with a load capacity of 350 kg/m² is reserved for the APS and BPS.

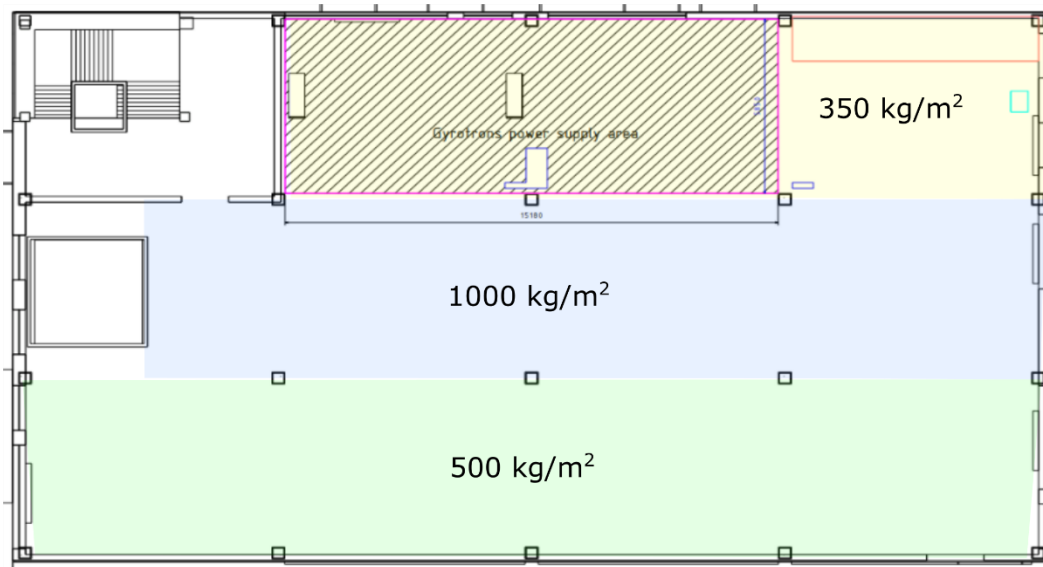

Figure 23: Layout of 3rd floor dedicated to ECRH – floor maximal load

7.3. Crane parameters

Components of the HV PS system can be lifted up to the 3rd floor via the crane through a hole in the floor which reaches down to the first (external ground level) floor.

Rated lifting capacity	5000 kg
Lifting height (from 3rd floor to hook)	2700 mm
Maximum Lifting height (from 1st floor to hook)	11000 mm
Minimum Lifting height (from 1st floor to hook)	1000 mm

Table 16: Key parameters of crane on the ECRH floor

7.4. Environmental conditions

Magnetic field from tokamak and gyrotrons:

Due to the close proximity of the ECRH building to the tokamak hall and the presence of gyrotrons with their superconductive magnets, there is a non-negligible stray magnetic field (i.e. greater than background levels) in the ECRH building.

REQ 145: The HV PS shall meet its requirements with no degradation in performance when exposed to stray magnetic field up to 3 mT.

Indoor temperature:

REQ 146: The HV PS shall meet its requirements with no degradation in performance when exposed to an ambient temperature range from 10 to 40 °C.

Humidity:

REQ 147: The HV PS shall meet its requirements with no degradation in performance when exposed to a variable humidity range. Humidity in the ECRH building is not controlled but the air ventilation system ensures an exchange of the air volume 2 times per hour.

8. Documentation

For all High Voltage Power Supply components, the Buyer requires the necessary documentation for its successful operation, maintenance and repairs even after a long period of operation. Specifically required is:

- Project design documentation
- Quality assurance plan (Test plan): list of proposed FAT and SAT tests
- As-built documentation:
 - i. documentation of all manufactured equipment
 - ii. documentation concerning safety rules and regulations
 - iii. documentation of all performed acceptance tests
- Accompanying documentation:
 - i. operational and maintenance documentation
 - ii. installation and commissioning instructions
- Assembly documentation
 - i. installation manual
 - ii. installation plan

The requirements listed in this chapter shall be fulfilled in a way that the documentation provided contains overall information for the entire HV PS system. The documentation shall be prepared in English language. The documentation is subject to the approval of the Buyer.

REQ 148: At the completion of the contract, all documentation provided throughout the contract shall be supplied in a single documentation pack to the Buyer, digital format (see Table 4), and English language.

8.1. Project design documentation

Provides detailed design documentation and specification of the proposed technical solution of the designed equipment, including:

- Technical drawings
- Connection schemes and diagrams
- Installation plan
- Parameters and tolerances of the individual parts
- Grounding scheme of the entire system
- Cooling scheme/strategy
- Failure Analysis
- Safety requirements, including control and regulation of the individual systems
- Analysis of the lifetime of the components
- Simulations of the waveforms

REQ 149: A draft of the Project design documentation shall be delivered by the Seller at the Design Review for approval by the Buyer. If the Buyer does not approve the documentation, it shall be returned to the Seller for correction and rewriting.

8.2. Quality assurance plan

Provides a plan and detailed description of all checks and tests necessary for the successful realization of the project, including FAT and SAT tests (Test Plan).

- Complete list of the FAT and SAT tests
- Detailed description of the FAT and SAT tests
- Exact required values and thresholds to be achieved during the tests
- Inspection, surveillance and audit procedures
- Management of non-conforming products and corrective actions

REQ 150: A draft of the Quality assurance plan shall be delivered by the Seller at the Design Review for approval by the Buyer. If the Buyer does not approve the documentation, it shall be returned to the Seller for correction and rewriting.

8.3. As-built documentation

Detailed description of the final, real status of the manufactured equipment at the time of signature of all protocols of the SAT, including:

- Technical drawings
- Connection schemes and diagrams
- Technical sheets of the used components
- Revision documentation of components
- Declarations of conformity to the required standards
- Documentation of all performed acceptance tests
- Documentation of all performed simulations
- Communication protocols documentation and signal description

8.4. Accompanying documentation

Detailed description of the operation, handling and maintenance of the equipment and its accessories, including:

- Operation manuals
- Instructions for regular maintenance of the components
- Instructions for installation and commissioning

In the manuals and the other Accompanying documentation, the Seller shall specify the operation and maintenance rules for the HV PS system to ensure the long-term durability and functionality of the structure.

8.5. Assembly documentation

Detailed installation manual and installation plan including:

- Relevant drawings
- Work plan
- Description of work procedures

REQ 151: All required technical documentation necessary for the Buyer to assemble the HV PS without error shall be delivered by the Seller for approval by the Buyer before the start of the Assembly. If the Buyer does not approve the documentation, it shall be returned to the Seller for correction and rewriting.

9. Delivery

REQ 152: Any partial delivery of any part the HV PS system according to the Contract can only be handed over after all relevant FAT tests have been successfully passed and all relevant components have been completely delivered to the Buyer's site. Individual handovers shall be then confirmed by signing the relevant handover protocol.

10. Assembly

REQ 153: The Seller shall provide professional supervision during the assembly of the equipment and shall promptly address any ambiguities or questions raised by the Buyer to ensure that the works can proceed smoothly in accordance with the agreed schedule.

REQ 154: The assembly period shall be at least two (2) months. This period shall commence upon delivery of: (i) items No. 1, 2, 3, and 4 from BID (see Annex No. 3 - Price Schedule and Deliverables_HVPS); (ii) items No. 2, 3, and 4 from Table 7 in the event that they are ordered; (iii) all required technical documentation necessary for the Buyer to assemble the HV PS without error including the installation plan, relevant drawings, and work procedure.

REQ 155: The Seller shall, without undue delay after completion of the assembly, take over the HV PS from the Buyer and shall confirm the takeover by signing the handover protocol.

11. Commissioning

REQ 156: The Seller shall propose and carry out tests to confirm at the beginning of the commissioning that there has been no change in the performance of the parts tested during the FAT.

REQ 157: The Seller shall provide a commissioning plan that outlines the procedure following the equipment installation and any maintenance activity.

REQ 158: The Seller is responsible for commissioning prior to the realization of the SAT. All associated costs for the HV PS commissioning are borne by the Seller.

12. Acceptance Tests

The Buyer proposes a flexible testing strategy that is adapted to the Seller's facility to perform component and integrated testing. The Seller is requested to develop a testing strategy that demonstrates compliance by performing a set of tests at the Factory (Factory Acceptance Tests or FAT) and at the Seller's Site (Site Acceptance Tests or SAT).

The testing strategy include the appropriate component, assembly and integrated testing, which are performed during the FAT and/or SAT. Note that some tests should be repeated at both locations to validate consistent functioning at both locations. A provisional distribution of the tests between the FAT and SAT is provided in Table 17. Note that this list represents a minimum of tests.

The Seller accepts the limitation that a full integrated testing of the HV PS transitioning between the load and no-load operation cannot be performed until after the SAT when the HV PS system is connected to the gyrotron. The Seller shall provide support in the event the HV PS system encounters issues as part of the Warranty period.

In general, all tests are expected to be compliant with the relevant IEC Standard. For equipment not covered by an IEC or equivalent standard, an appropriate testing shall be proposed by the Seller and agreed upon by the Buyer during the Design Review.

REQ 159: The Seller shall provide a complete Test Plan for the Buyer's approval as part of Design Review. The Test Plan is to include all testing procedures, locations, equipment/instrumentation requirements, acceptance thresholds, etc.

REQ 160: The Seller's Test Plan shall include all tests listed in Table 17 and any other tests that are required to ensure complete compliance of the HV PS system.

REQ 161: The Seller is responsible for performing all FAT and SAT tests that will be included in the agreed Test Plan.

REQ 162: Either FAT and/or SAT should include the MPS, BPS, APS, and HV PS Standard Pulses (see Figure 24) at varying pulse lengths and voltage settings to validate all requirements described in Sec. 5 and associated tables. The pulse lengths and voltage settings are to be agreed upon by the Buyer in the Test Plan.

REQ 163: The Seller should provide simulations of individual or integrated tests that could not be performed at either the FAT or SAT, which includes, but is not limited to, operations with the Buyer’s flywheel generator and the integrated load – no-load operation with the gyrotron utilising the ASM switching.

REQ 164: The Buyer has a right to supervise and participate on both FATs and SATs, including use of additional measurement systems installed by the Buyer.

ID	Test	FAT	SAT	Comment
T17-01	MPS Transformer Tests	X		See: Sec. 12.11
T17-02	MPS Power Module Tests	X		See: Sec. 12.1
T17-03	MPS Full Assembly Tests	X		See: Sec. 12.2
T17-04	BPS Tests	X		See: Sec. 12.3
T17-05	APS and ASM Tests	X		See: Sec. 12.4
T17-06	Ancillary Systems Tests		X	See: Sec. 12.10
T17-07	Coolant Systems Tests		X	See: Sec. 12.9
T17-08	Control System Tests		X	See: Sec. 12.8
T17-09	Pulse Demonstration Tests		X	See: Sec. 12.5
T17-10	Arc Energy Tests		X	See: Sec. 12.6
T17-11	Reverse Voltage Test / Overvoltage Test		X	See: Sec. 12.7
T17-12	HV cables and receptacles tests	X		See: Sec. 12.12
T17-13	CHPS tests	X		See: Sec. 12.13

Table 17: The proposed Test Plan distributed between the FAT and SAT. Note that the Seller may recommend an alternative distribution of tests, but this list represents a minimum of tests that should be performed. The preferred location of the tests are marked with an “X”, with some tests proposed to be performed at both locations. The Seller may propose an alternative Test Plan location distribution.

REQ 165: The voltage measurements should be performed at each of the power supply outputs except the Arc Energy tests, where the measurements shall be performed at the end of the cabling prior to the connection to the gyrotron.

REQ 166: The shunts for measuring the currents should be within each power supply and located on the high voltage output (non-ground).

12.1. MPS Power Module Tests

REQ 167: At least one MPS power module should be tested to be shown compliant with operating at 120% of the nominal voltage of the module. The tests can be performed with lower output current than the nominal current I_k (but non-zero current).

REQ 168: At least one MPS power module should be tested to be shown compliant with operating at 110% of the nominal current I_k under the maximum Pulse Length (load + no-load) and Duty Cycle requirements specified in Table 12. The tests can be performed at lower output voltage than the nominal voltage of the module.

REQ 169: The Seller shall propose measurements that enable evaluation of the thermal conditions of all components of the MPS power module under the worst-case scenario. It is the responsibility of the Seller to propose such worst-case scenario to be approved by the Buyer.

REQ 170: The tested module(s) may subsequently be used in the MPS power supply.

Note: MPS Full Assembly Tests and Pulse Demonstration Tests will be carried out with 1 s pulse length and full current and voltage rating, for the purpose of simplifying the technical requirements for the MPS DL.

12.2. MPS Full Assembly Tests

REQ 171: The MPS should be tested to be shown compliant with all parameters specified in Table 12 and Sec. 5.2 with the MPS connected to the MPS DL. The tests will be limited by the MPS DL parameters (see Sec. 5.9.1). Testing to at least 90% of the nominal voltage V_k , and to at least 50% of the nominal current I_k is sufficient.

When tested to be shown compliant with operating at $\geq 90\%$ of the nominal voltage V_k , the tests can be performed with lower output current than the nominal current I_k (even zero current).

When tested to be shown compliant with operating at $\geq 50\%$ of the nominal current I_k , the tests can be performed at lower output voltage than the nominal voltage V_k , however all power modules must contribute to the output voltage equally.

REQ 172: The MPS assembly tests shall ensure sufficient number of pulses to provide a sufficient statistical database of its performance.

12.3. BPS Tests

REQ 173: The BPS should be tested to be shown compliant with all parameters specified in Table 13 and Sec. 5.3 with the BPS connected to the BPS DL.

REQ 174: The BPS assembly tests shall ensure sufficient number of pulses to provide a sufficient statistical database of its performance.

12.4. APS and ASM Tests

REQ 175: The APS should be tested to be shown compliant with all parameters specified in Table 14 and Sec. 5.4 with the APS connected to the APS DL.

REQ 176: The APS assembly tests shall ensure sufficient number of pulses to provide a sufficient statistical database of its performance.

REQ 177: The FAT and/or SAT should include the ASM Switching tests to validate the specified APS voltage modulation frequency, reaction time, ramp speeds and pulse shape as specified in Table 15.

12.5. Pulse Demonstration Tests

Pulse Demonstration Tests follow successful commissioning of the HV PS system. Their purpose is to test the HV PS for the gyrotron in the final configuration, with all components connected and using the supplied control system.

REQ 178: The HV PS system shall be tested as an integral unit using the dummy loads (MPS, BPS, and APS dummy loads) to ensure compliance with this set of technical specifications, the Seller's design requirements, and the correct control and shutdown signal reactions.

REQ 179: MPS Pulse demonstration tests shall demonstrate correct operation under 1 s pulse length, current 110 A, and nominal voltage.

REQ 180: BPS and APS Pulse demonstration tests shall demonstrate correct operation under 1 s pulse length and nominal parameters.

REQ 181: The HV PS integrated testing shall include operation with the duty cycle of individual power supplies.

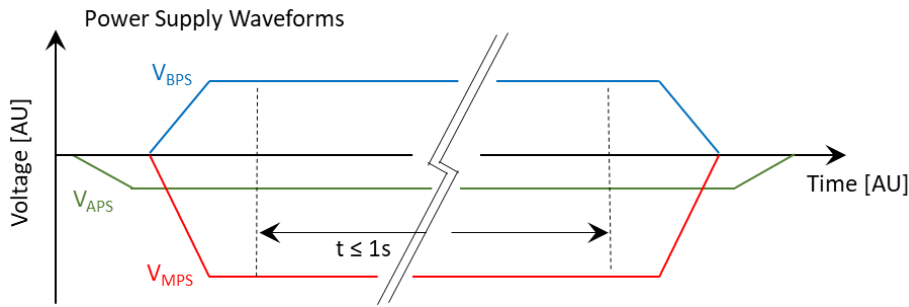

Figure 24: Standard Pulse to be used for testing of the MPS, BPS, and APS for SAT. Note that the traces are generic with the amplitude and pulse duration to be determined prior to the FAT in agreement between the Seller and the Buyer. The traces may be used for the individual testing of each PS and/or assembly testing of the HV PS system.

REQ 182: The voltage overshoot/undershoot, ripple, setability, reproducibility and accuracy shall be measured for each of the traces in REQ 184.

REQ 183: The internal signal generator shall be capable of generating reference traces consistent with all timing requirements specified in Table 12, Table 13, and Table 14.

REQ 184: Pulse demonstration test shall include the MPS, BPS, and APS operating with Voltage Ramp Pulses (see Figure 25 and Figure 26) with the Buyer specifying the specific pulse shape(s) prior to the FAT and/or SAT.

REQ 185: Each Voltage Ramp Pulse (see REQ 184) shall be repeated for at least 10 pulses to ensure compliance on the error bars for each specification of Sec. 5.

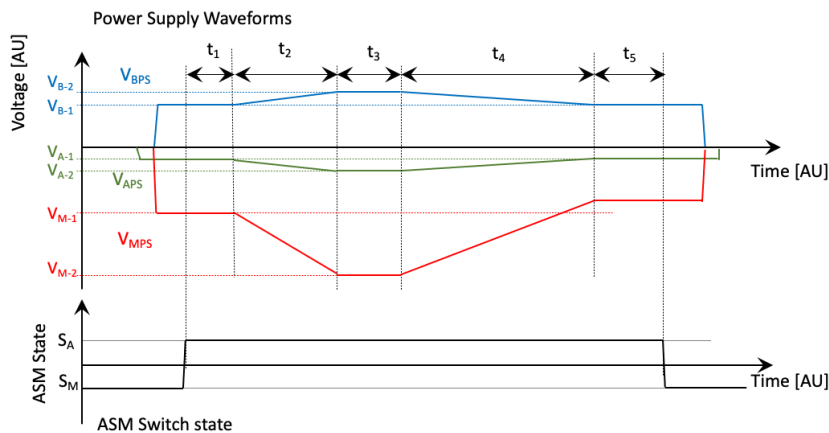

Figure 25: Voltage Ramp Pulse to be used for testing of the MPS, BPS and APS for both FAT and SAT. The duration of each ramp (t_2 and t_4) as well as the flat top durations (t_1 , t_3 , t_5) as well as the voltage levels ($V_{\#-1}$ and $V_{\#-2}$) are to be determined prior to the FAT in agreement between the Seller and the Buyer. The traces may be used for the individual testing of each PS and/or assembly testing of the MPS set.

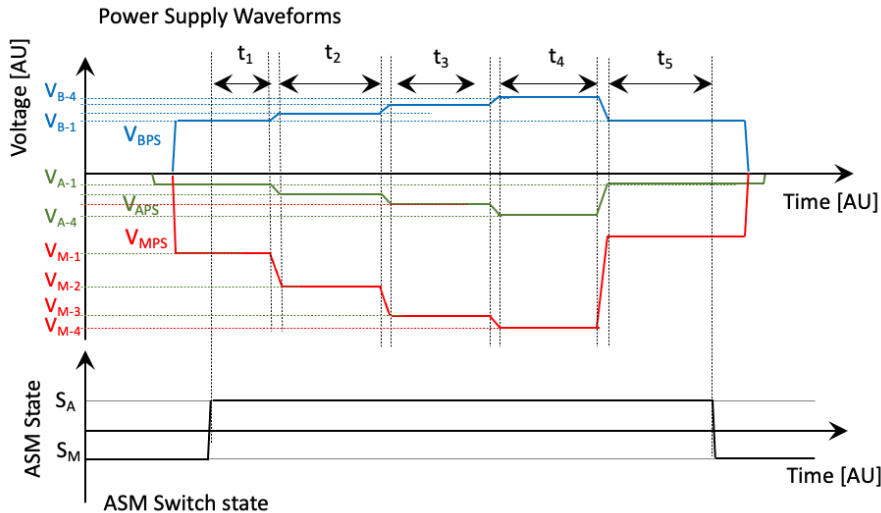

Figure 26: Voltage Step Pulse to be used for testing of the MPS, BPS and APS for both FAT and SAT. The duration (t_1 to t_4), number of steps, and voltage levels ($V_{\#-1}$ to $V_{\#-4}$) for each step are to be determined prior to the FAT in agreement between the Seller and the Buyer. The traces may be used for the individual testing of each PS and/or assembly testing of the MPS set.

12.6. Arc Energy Tests

REQ 186: The Seller shall demonstrate the HV PS system complies with the arc limit energy for the MPS, BPS, and APS using the Wire Burn technique, which ensures the limit of Arc Energy to <10 J. An alternative may be acceptable, but shall be agreed in advance by the Buyer.

REQ 187: The Seller shall demonstrate the arc limit by the Wire Burn technique at the end of the cable that is connected to the gyrotron interface.

12.7. Reverse Voltage Test / Overvoltage Test

REQ 188: The Seller should perform tests to verify the ability of all power supplies to withstand any events caused by a short circuit between the gyrotron electrodes and proper reaction of the control system to these events (see: Sec. 5.10.4). The control system must respond solely based on voltage and current measurements of the HV PS, without receiving any external signal. The Seller shall propose the tests and submit them to the Buyer for approval.

12.8. Control System Tests

REQ 189: The Seller shall perform a test to verify that the control system is compliant with all requirements for real-time communication. The Seller shall propose the test procedure for real-time communication verification and submit it to the Buyer for approval.

REQ 190: All components of the HV PS system shall be tested to verify that they perform a safe shutdown in the event of all input power networks failure.

REQ 191: All SAT tests shall be performed using the supplied control system through the HMI. This includes correct operation of all interlock signals.

REQ 192: All tests shall be capable of being performed in Remote Operation. The Seller will select a set of tests to be repeated in the Remote Operation mode to ensure this functionality.

REQ 193: The HV PS control system shall be tested to demonstrate compliance with the requirements of Sec 5.1.5.

12.9. Coolant System Tests

REQ 194: Any system requiring liquid coolant shall be subject to appropriate pressure and leak tests.

REQ 195: The pressure tests associated with all liquid coolant circuits shall be at either the maximum working pressure or 1.43 times the maximum allowable pressure.

12.10. Ancillary System Tests

REQ 196: The SAT shall include testing of all ancillary systems (ancillary systems, switching circuits, Human-Machine Interface, shutdown signals, interlocks, etc.) during a nominal operating period.

12.11. MPS Transformer Tests

REQ 197: Provide technical documentation and test protocols issued by the manufacturer according to valid Czech and European rules and regulations.

12.12. HV cables and receptacles tests

REQ 198: Provide technical documentation and test protocols issued by the manufacturer(s) according to valid Czech and European rules and regulations.

12.13. CHPS tests

REQ 199: Provide technical documentation and test protocols issued by the manufacturer(s) according to valid Czech and European rules and regulations.

12.14. Acceptance Tests documentation and organisation

The Seller may provide certified copies of the type test certificates covering the equipment of identical design, rating and construction, pending approval by the Buyer.

REQ 200: All FAT, SAT tests shall be documented by the Seller.

REQ 201: The Seller shall immediately notify the Buyer of any failed tests, and provide a written non-conformance report documenting the failure and corrective actions required.

REQ 202: The Seller shall undertake corrective action as needed during FAT, SAT to diagnose and rectify any non-compliances / non-conformances.

REQ 203: Unless otherwise stated time traces and raw data should be provided from all the tests.

REQ 204: Ancillary equipment that are Off-the-Shelf (such as cabling, connectors, fuses etc.) shall include the relevant documentation of standards compliance, and considered as type tested; requiring only testing as part of the relevant assembly.

REQ 205: The Seller shall notify the Buyer prior to the start of any testing works. The Buyer will respond within 10 days if the tests are to be witnessed by the Buyer, or the Buyer's representative.

REQ 206: The time by which the Seller shall be informed before the start of the tests shall be agreed upon and approved during the Design Review.

12.15. Rejection of Plant

REQ 207: Any component or assembly that fails to comply with any requirements of this specification during the manufacturing or testing phase may be subject to rejection (either in part or as a whole) by the Buyer.

REQ 208: Any component or assembly that has not successfully passed any of the tests during manufacturing, FAT or SAT shall be adjusted, modified, repaired or replaced by the Seller at no charge to the Buyer.

REQ 209: Any component or assembly that has been adjusted, modified, repaired or replaced during the manufacturing or testing shall be subject to a repeat of all testing as necessary to demonstrate compliance with all costs borne by the Seller.

REQ 210: The Seller's delivery shall be considered complete only upon successful passing of all tests, unless otherwise agreed by the Buyer.

13. Codes and Standards

REQ 211: The design, manufacturing and testing of all components of the HV PS system shall be in accordance with the most recent issues of the relevant IEC Standards and Recommendations.

REQ 212: All components of the HV PS system shall comply with valid European standards and installation regulations, including protection against electric shock.

14. Project Management

14.1. Project Milestones

REQ 213: The Seller shall adhere to the project milestones defined in Table 18 unless otherwise agreed with the Buyer.

REQ 214: The technical documentation provided at design reviews shall be in accordance with Table 3 at a minimum.

REQ 215: The acceptance of the required documents related to individual milestones will be confirmed by signing the Handover Protocol.

REQ 216: The milestone is considered achieved when all documents (Table 3) and services (Table 1) marked as relevant for the given milestone have been delivered.

REQ 217: The Seller shall also provide project management documentation, including but not limited to:

- a. Schedule
- b. Risk Register
- c. Meeting minutes
- d. Progress reports

REQ 218: A regular meeting structure shall be mutually agreed at the Kick-Off Meeting, along with agreement on procedures for managing document exchange, CAD exchange, change control, and risk management.

REQ 219: The Buyer reserves the right to designate selected manufacturing, inspection and/or test operations as mandatory Witness or Hold points. The Seller and its subcontractors are responsible for the safety of the Buyer's representatives visiting the manufacturing and/or testing site. The Buyer reserves the right to attend the Seller or Sub-Supplier facilities for any of the following, provided sufficient notice is given:

- a. Manufacturing
- b. Factory Acceptance Tests (including of sub-systems)

ID	Milestone	Deadline	Project milestones / review points	Notes (to be included, but not limited to)	Milestone fulfilment documents
KOM		No later than 2 weeks after the Contract becomes effective	Kick-Off Meeting	Introduce key personnel; agree CAD standards to be used; list of major sub-suppliers; present and review schedule; agree meeting structure; agree change control.	
DR	M1	No later than 4 months after the Contract becomes effective	Design Review of HV PS		Approved documents labelled as DR in Table 3; Handover protocol of the Design Review of HV PS
DEL	M2	According to the schedule proposed by the Seller.	Factory Acceptance Tests and Delivery	Successful completion of the FAT tests and successful delivery of all items to the Buyer's site, including Buyer's acceptance. The items No. 1, 2, 3, and 4 from BID (see Annex No. 3 - Price Schedule and Deliverables_HVPS) shall be delivered. In addition, items No. 2, 3 and 4 from Table 7 shall be delivered in the event that they are ordered.	Approved documents labelled as DEL in Table 3; Handover Protocol of Acceptance
ASB	M3	The Buyer will complete the assembly within two months after the signing of the handover protocol for milestone M2 acceptance.	Assembly	The provided supervision shall ensure a clear and unambiguous installation process and the formal handover of the assembly by the Seller upon completion.	
SAT		30/11/2027	Acceptance of Assembly, Commissioning, and Site Acceptance Tests	Successful completion of all SAT tests. Delivery of all documentation to the Buyer.	Approved documents labelled as SAT in Table 3. Please note that the signature of the Handover Protocol of Acceptance leads to payment of the Total Purchase Price (see Contract).

Table 18: Project Milestones

14.2. Inspection and Progress Meetings

REQ 220: The Buyer and the Seller shall meet at least once per 2 weeks to discuss the progress of the realization of the extent of delivery.

REQ 221: The form of such Regular online Progress Meetings is to be agreed between both sides and shall be organized by the Seller.

REQ 222: The Seller shall summarize the discussion that took place in Regular Progress Reports.

REQ 223: The Regular Progress Report of a meeting shall be submitted one week after the meeting took place at the latest.

REQ 224: The Seller shall allow presence of representatives of the Buyer during all stages of the manufacturing process.

REQ 225: The Buyer should be granted the right to make photo and video documentation of the work in progress. Traveling of the representatives to the production site is on the expenses of the Buyer.

14.3. Design review

To avoid misunderstandings and inapplicable design proposals, the Seller is encouraged to immediately contact the Buyer in case of any ambiguities or suggestions for unusual solutions.

REQ 226: The Seller shall provide the Buyer with the Design Review on time according the deadline in Table 18.

REQ 227: The final design presented to the Buyer on the Design Review shall include a detailed design of components in the Bill of Materials, and all the design information requested in Table 3.

REQ 228: All provided materials and documentation for the Design Review shall be in English.

REQ 229: The Buyer will provide the Seller with confirmation of the successful Design Review immediately after the Seller has resolved all objections to the submitted final design. Only the successfully passed Design Review establishes the right to pay the corresponding advance payment to the Seller, see Contract.

REQ 230: The Design Review acceptance by the Buyer will be confirmed by signing the Handover Protocol. The Handover Protocol may only be signed once the Seller has resolved all objections raised by the Buyer.

REQ 231: The deliverables defined for the design review are contained in Table 3.

- a. Documents shall be formally reviewed internally by the Seller prior to submission.
- b. Documents shall be provided a minimum of 1 weeks in advance of the meeting.

15. Quality Management

15.1. Quality Management System

REQ 232: The Seller shall have in place a Quality Management System such as ISO9001 or equivalent.

REQ 233: The Seller shall ensure that any major sub-suppliers also have in place a Quality Management System such as ISO9001 or equivalent.

REQ 234: The Seller shall have in place a Document Management System that ensures appropriate version control and document identification

15.2. 3D and 2D CAD

REQ 235: The Seller should provide CAD files to an appropriate standard e.g. ISO 128.

REQ 236: The CAD standard to be used shall be agreed with the Buyer at the Kick-Off Meeting.

15.3. Supply Chain Management

REQ 237: The Seller shall have a documented process for selecting sub-suppliers and monitoring their performance.

REQ 238: The Seller shall pass on all the relevant requirements in this Technical Specification to their sub-suppliers.

REQ 239: Seller shall have in place controls to ensure that all requirements are being met by their sub-suppliers.

15.4. Lifting Equipment

REQ 240: The Seller should provide EN 10204 2.1 materials certificates for fasteners and lifting accessories.

15.5. Calibration of test and measuring Equipment

REQ 241: Inspections and tests should be performed using properly calibrated measuring and test equipment. Calibration standards are assumed to be maintained by the Seller's ISO 9001 certification.

REQ 242: The Seller shall provide the Buyer valid calibration certificates if requested.

15.6. CE Marking / Regulatory Requirements

REQ 243: Commercial Off-the-Shelf items shall be supplied with appropriate certifications as required to meet regulatory requirements e.g. CE marking, or individual compliance statements against specific regulations e.g. The Restriction of Hazardous Substances Directive 2002/95/EC

REQ 244: This tender is subject to compliance with the requirements of Directive (2011/65/EU); in case the RoHS compliance cannot be achieved, the Buyer shall be informed, the non-compliance shall be justified and is a subject of approval by the Buyer.

16. Shipping, Storage and Handling

16.1. Identifier

REQ 245: All equipment shall be clearly labelled by the Seller with a unique reference number, the Buyer's contract or equivalent reference number.

16.2. Handling of parts and storage

REQ 246: The Seller shall store equipment in appropriate packaging, including where necessary

desiccants to absorb moisture.

REQ 247: The Seller shall store equipment in a secure facility, with minimal risk of contamination, excess heat, or moisture.

16.3. Packing and Crating

REQ 248: The Seller is responsible for packing.

REQ 249: Packing and shipping details shall be submitted by the Seller for review and approval by the Buyer.

REQ 250: The Seller shall include accelerometers, shock sensors, or equivalent to enable assessment upon delivery of any abnormalities in transit.

REQ 251: The external packaging shall be clearly labelled with details of the components within.

REQ 252: The external packaging shall contain clear handling instructions.

REQ 253: All components shall be prepared for shipment in such a manner to afford its protection from normal hazards of transportation.

REQ 254: The Seller shall pack items suitably for the agreed method of transportation (sea, road, rail, air, or other), also considering any lifting / handling operations.

REQ 255: The Buyer has the right to witness the packing procedure and thus shall be informed in time about planned operation.

16.4. On site delivery

On delivery, the Buyer will open the package and make a visual inspection to confirm that there is no visible damage to the package or goods; to check the accelerometer readings; and to confirm all equipment and documentation are included as expected. If this is all acceptable, the Buyer will provide a confirmation of this to the Seller.

REQ 256: The Seller retains full responsibility for the equipment until it is delivered and accepted at the Buyer's site.

16.5. Training

REQ 257: The Seller shall provide training for the working staff concerning the operation, maintenance and troubleshooting of all physical deliverables, including training focused on use of software and firmware – programming, deploying, functionality, errors description and searching for causes.

REQ 258: The Seller shall prepare an “Operation and Maintenance Manual” adequate to allow the Buyer to get a good understanding of the equipment, of its operating modes and of the procedures to carry out settings and checks of protections, control loops, maintenance interventions, etc.

REQ 259: The Seller shall provide informal instruction during the execution of the Contract, especially during the factory and site testing and commissioning. When the representatives of the Buyer are present, they will be allowed to ask a reasonable number of questions and to seek clarifications.

REQ 260: The Seller shall provide on-site training how to handle all programmable devices. The training will be attended by the Buyer's technical staff. It will take place at the Buyer's premises and will last 1–2 days. The exact scope and format of the training will be agreed with the buyer during the Design Review.

17. List of Annexes

Number	Name	Description
No. 1	Building drawings	ISO view and selected cuts of the places allocated for the HV PS installation.
No. 2	Waveform of HV grid	Data files (txt and Matlab formats) of the voltage waveforms of the HV grid supplying the MPS.

Table 19: List of annexes