

## KUPNÍ SMLOUVA Č. 0542/24

Níže uvedeného dne, měsíce a roku smluvní strany:

### Univerzita Pardubice

Právní forma: veřejná vysoká škola zřízená zákonem  
Se sídlem: Studentská 95, 532 10 Pardubice  
Zastoupená: prof. Ing. Liborem Čapkem, Ph.D., rektorem  
IČO: 00216275  
DIČ: CZ00216275  
Bankovní spojení: Komerční banka, a.s., pobočka Pardubice  
Číslo účtu: 37030561/0100  
Kontaktní osoba: [REDACTED]

(dále jen „kupující“)

a

### ATEsystem s.r.o.

Se sídlem: Technologická 375/3, Pustkovec, 708 00 Ostrava  
Zapsaná: v obchodním rejstříku vedeném Krajským soudem v Ostravě  
oddíl C, vložka 55698  
Zastoupená: [REDACTED]  
IČO: 01392042  
DIČ: CZ01392042  
Bankovní spojení: Česká spořitelna a.s.  
Číslo účtu: [REDACTED]  
Kontaktní osoba: [REDACTED]

(dále jen „prodávající“)

uzavřely dle § 2079 a násl. zákona č. 89/2012 Sb., občanský zákoník, ve znění pozdějších předpisů (dále jen „OZ“) v rámci projektu OP JAK Infrastrukturní zázemí doktorských studijních programů na Univerzitě Pardubice (DSP INFRA), CZ.02.01.01/00/22\_012/0005962 (OP JAK), tuto kupní smlouvu (dále jen „smlouva“):

### I. Předmět smlouvy

1. Prodávající se zavazuje na základě své nabídky ze dne 25. 4. 2024 k veřejné zakázce s názvem „**Dodávka systému pro širokopásmový komplexní optický záznam**“ (dále jen „Veřejná zakázka“), zadávané v souladu s § 31 zákona č. 134/2016 Sb., o zadávání veřejných zakázek, ve znění pozdějších předpisů (dále jen „ZZVZ“), dodat kupujícímu v rozsahu a za podmínek stanovených touto smlouvou **1 ks systému pro širokopásmový komplexní optický záznam složeného z 1 ks hyperspektrální NIR kamery, 1 ks vysokorychlostní průmyslové kamery s podporou vysokého rozlišení, 1 ks kompaktního FT infračerveného spektrometru a**



Spolufinancováno  
Evropskou unií



nezbytnou dokumentaci (dále jen „zboží“) a převést na kupujícího vlastnické právo k tomuto zboží. Zboží je podrobně specifikováno v příloze č. 1 této smlouvy – „Specifikace předmětu plnění“.

2. Zboží musí být nové, nepoužité, plně funkční, nerenovované, kompletní a v souladu se specifikací uvedenou v příloze č. 1 této smlouvy tak, aby bylo možné jeho plné využití.
3. Prodávající je povinen zboží dodat do místa plnění dle čl. III. odst. 1. této smlouvy v originálních obalech výrobce zboží ve sjednaném množství, jakosti, provedení a čase.
4. Prodávající je povinen zboží nainstalovat včetně softwaru, uvést ho do provozu včetně prověření bezchybné funkčnosti zboží a předvedení deklarovaných parametrů v místě a době plnění dle čl. III. této smlouvy.
5. Prodávající se zavazuje zajistit, aby bylo kupujícímu poskytnuto právo k užití softwaru v souladu se zákonem č. 121/2000 Sb., o právu autorském, o právech souvisejících s právem autorským a o změně některých zákonů (autorský zákon), ve znění pozdějších předpisů a nebyla užitím softwaru kupujícím dotčena práva třetích osob.
6. Prodávající je povinen provést k obsluze zboží potřebné zaškolení min. 2 zaměstnanců kupujícího v českém jazyce nebo anglickém jazyce v místě a době plnění dle čl. III. této smlouvy v rozsahu nezbytně nutném pro obsluhu zboží.
7. Prodávající je povinen při předání zboží dle čl. IV. této smlouvy předat kupujícímu prohlášení o záruce, resp. záruční list na zboží, technickou dokumentaci, uživatelské příručky a veškerou další dokumentaci potřebnou k provozování zboží v českém jazyce nebo anglickém jazyce.
8. Kupující se zavazuje zboží převzít a zaplatit prodávajícímu dohodnutou kupní cenu dle čl. II. odst. 1. této smlouvy.

## II. Kupní cena

1. Smluvní strany se ve smyslu zákona č. 526/1990 Sb., o cenách, v platném znění, dohodly na této kupní ceně zboží:

Sjednaná kupní cena zboží: 1 446 690,- Kč bez DPH

2. Sjednaná cena ve smlouvě je uvedena bez daně z přidané hodnoty a daň z přidané hodnoty bude k této ceně účtována dle daňových předpisů platných v okamžiku uskutečnění zdanitelného plnění dle zákona č. 235/2004 Sb., o dani z přidané hodnoty, ve znění pozdějších předpisů (dále jen „ZDPH“).
3. Sjednaná cena uvedená v odst. 1. tohoto článku je cena nejvýše přípustná a neměnná po celou dobu účinnosti této smlouvy. Ve sjednané ceně jsou zahrnuty veškeré náklady prodávajícího spojené s plněním povinností dle této smlouvy (např. náklady na balné, skladné, dopravu, pojištění, instalaci, ověření a předvedení funkčnosti v místě plnění, zaškolení aj.). Prodávající není oprávněn účtovat žádné další částky v souvislosti s plněním dle této smlouvy.



### III. Místo a doba plnění

1. Místem plnění pro dodání zboží včetně instalace a zaškolení je objekt kupujícího, a to Fakulta elektrotechniky a informatiky, budova CA, 1. patro, místnost 01-035, na adrese náměstí Čs. legií 565, 530 02 Pardubice. Osobou, kterou kupující pověřil k převzetí zboží, je kontaktní osoba uvedená v úvodních ustanoveních této smlouvy (dále jen „příjemce“), popř. jiná, kupujícím pověřená, osoba.
2. Prodávající je povinen řádně dodat kupujícímu zboží do místa plnění v rozsahu dle čl. I. této smlouvy nejpozději do 20 kalendářních týdnů ode dne podpisu smlouvy poslední smluvní stranou.
3. Prodávající je povinen dodat kupujícímu zboží v místě plnění v pracovních dnech od 08:00 hod. do 15:00 hod., mimo tuto dobu pouze ve výjimečných případech a po předchozí dohodě s příjemcem. Dále je povinen telefonicky vyrozumět příjemce o připravenosti dodat zboží a provést jeho zprovoznění, a to nejméně 3 pracovní dny předem.

### IV. Předání a převzetí zboží

1. Povinnost prodávajícího dle čl. I. této smlouvy je považována za splněnou provedením převímky zboží příjemcem či jeho pověřeným zástupcem a prodávajícím či jeho pověřeným zástupcem v místě a době plnění dle čl. III. této smlouvy. Kupující není povinen převzít zboží, které vykazuje jakoukoliv vadu či nedodělek.
2. Převímkou se rozumí předání zboží včetně splnění všech podmínek stanovených v čl. I. této smlouvy prodávajícím a převzetí zboží příjemcem. Zjistí-li příjemce, že zboží trpí vadami, odmítne jeho převzetí s vytčením vad. O takovém odmítnutí sepíše smluvní strany zápis. Povinnost prodávajícího dle čl. III. odst. 2. této smlouvy tím není dotčena.
3. O provedení převímky bude prodávajícím a příjemcem sepsán převímací protokol s uvedením data provedení převímky. Toto datum je dnem dodání zboží, resp. souvisejících plnění v rozsahu dle čl. I. této smlouvy a je rozhodné pro splnění povinnosti prodávajícího dle čl. III. odst. 2. této smlouvy. V převímacím protokolu prodávající zejména uvede označení smluvních stran, označení zboží, jeho množství, čitelné jméno a podpis, příjemce uvede též své čitelné jméno a podpis.
4. Svépomocný prodej dle § 2126 a násl. OZ se nepoužije.

### V. Fakturační a platební podmínky

1. Právo fakturovat vzniká prodávajícímu okamžikem převímky zboží v rozsahu dle čl. I. této smlouvy.
2. Prodávající je povinen, po vzniku práva fakturovat, do 15 dnů vystavit a doručit kupujícímu originál daňového dokladu (dále jen „faktura“) za řádně dodané zboží za dohodnutou smluvní



cenu. Faktura bude mít náležitosti řádného účetního a daňového dokladu ve smyslu příslušných právních předpisů, zejména ZDPH ve znění pozdějších předpisů. Na faktuře bude uvedeno evidenční číslo této smlouvy zaznamenané v jejím názvu. Dále bude na faktuře uvedeno číslo interní objednávky kupujícího, které kupující sdělí prodávajícímu při podpisu smlouvy. Dále bude na faktuře uvedeno, že se jedná o dodávku pro projekt Infrastrukturní zázemí doktorských studijních programů na Univerzitě Pardubice (DSP INFRA), CZ.02.01.01/00/22\_012/0005962 (OP JAK).

3. Společně s fakturou je prodávající povinen předložit též přejímací protokol potvrzený příjemcem.
4. Faktura může mít listinnou nebo elektronickou podobu. Splatnost faktury činí 30 dnů - v případě listinné podoby ode dne jejího prokazatelného doručení na adresu sídla kupujícího uvedenou v úvodních ustanoveních této smlouvy, v případě elektronické podoby ode dne jejího prokazatelného doručení na e-mailovou adresu: [fakturace@upce.cz](mailto:fakturace@upce.cz). Kupující tímto souhlasí s elektronickou formou fakturace a zavazuje se neprodleně informovat prodávajícího o jakékoliv změně e-mailové adresy pro zasílání faktur a dále se zavazuje, že zajistí řádnou funkčnost uvedené e-mailové adresy po dobu trvání této smlouvy. Jestliže bude z okolností zřejmé, že fakturu nelze na uvedenou e-mailovou adresu doručit, např. se zpráva vrátí jako nedoručitelná, bude neprodleně na adresu sídla kupujícího uvedenou v úvodních ustanoveních této smlouvy zaslána faktura v listinné podobě, přičemž však bude faktura splatná v termínu, jako by byla úspěšně doručena prostřednictvím e-mailu.
5. V případě, že faktura bude obsahovat nesprávné nebo neúplné údaje nebo k ní nebudou přiloženy požadované doklady, je kupující oprávněn vrátit ji do data její splatnosti prodávajícímu, aniž se tak dostane do prodlení se splatností. Proávající vrátí fakturu opraví, eventuálně vyhotoví novou, bezvadnou. V takovém případě běží kupujícímu nová doba splatnosti dle odst. 4. tohoto článku ode dne doručení opravené nebo nové faktury.
6. Kupující neposkytuje zálohové platby.
7. Platby budou probíhat výhradně v Kč formou bezhotovostního převodu na účet prodávajícího uvedený v úvodních ustanoveních této smlouvy.
8. Smluvní strany se dohodly, že nastane-li v souvislosti s prodávajícím jakákoliv skutečnost, v jejímž důsledku se může vůči kupujícímu uplatnit ručení za daň odváděnou prodávajícím ve smyslu ZDPH, je kupující oprávněn nezaplatit prodávajícímu vyúčtovanou DPH a odvést ji přímo správci daně a kupující je rovněž oprávněn odstoupit od této smlouvy.
9. Proávající prohlašuje, že na sebe přebírá nebezpečí změny okolností podle § 1765 odst. 2 OZ, § 1765 odst. 1 a § 1766 OZ se tedy ve vztahu k prodávajícímu nepoužije.



## **VI. Práva a povinnosti smluvních stran, vlastnické právo a nebezpečí škody na zboží**

1. Prodávající je povinen při plnění této smlouvy postupovat s odbornou péčí, dodržovat obecně závazné právní předpisy, normy a další předpisy vztahující se k předmětu smlouvy, podmínky této smlouvy a pokyny kupujícího.
2. Kupující se zavazuje poskytnout prodávajícímu při plnění předmětu této smlouvy nezbytnou součinnost.
3. Vlastnické právo ke zboží přechází z prodávajícího na kupujícího provedením přejímky zboží dle čl. IV. této smlouvy.
4. Nebezpečí škody na zboží přechází na kupujícího ve smyslu ustanovení § 2121 odst. 1 OZ provedením přejímky zboží dle čl. IV. této smlouvy.

## **VII. Záruka za jakost a reklamační podmínky**

1. Prodávající poskytuje kupujícímu na zboží záruku za jakost a vlastnosti zboží, jež odpovídají předmětu a účelu této smlouvy, a to v délce trvání 12 měsíců ode dne provedení přejímky zboží. Sjednaná záruční doba neplatí pro zboží, na které je výrobcem tohoto zboží stanovena záruční doba delší.
2. Kupující je povinen u prodávajícího písemně (tj. i elektronicky) uplatnit zjištěné vady zboží (dále jen „reklamace“ resp. „oznámení o reklamaci“) bez zbytečného odkladu poté, co je zjistil. Prodávající je povinen kupujícímu doručit písemné (tj. i elektronicky) vyjádření k reklamaci ve smyslu § 2117 OZ s odkazem na § 2173 OZ v době do 5 pracovních dnů po jejím obdržení. Pokud během této doby nebude kupujícímu doručeno písemné vyjádření prodávajícího k reklamované vadě, platí, že prodávající uznává reklamaci v plném rozsahu. I reklamace odeslaná kupujícím v poslední den záruční doby se považuje za včas uplatněnou.
3. Prodávající je povinen bezplatně odstranit reklamované vady, které uznal nebo ke kterým se nevyjádřil podle odst. 2. tohoto článku, a to v místě plnění nejpozději do 30 kalendářních dnů ode dne doručení oznámení o reklamaci, nedohodnou-li se obě smluvní strany jinak.
4. Kupující má právo uplatnit reklamaci i v případě, jedná-li se o vadu zboží, kterou musel s vynaložením obvyklé pozornosti poznat již při přejímce zboží.
5. Záruční doba se automaticky prodlužuje o počet dnů uplynulých od nahlášení vady do podpisu protokolu o odstranění vady.
6. Prodávající se zavazuje, že si v záruční době nebude účtovat cestovní či jiné náklady.



## VIII. Smluvní pokuty a úrok z prodlení

1. V případě prodlení prodávajícího s dodáním zboží (či jeho části) a/nebo se splněním povinnosti dle čl. I. této smlouvy ve sjednané době dle čl. III. odst. 2. této smlouvy, je kupující oprávněn požadovat po prodávajícím zaplacení smluvní pokuty ve výši 0,1 % ze sjednané kupní ceny bez DPH za každý i započatý den prodlení až do výše sjednané kupní ceny bez DPH.
2. V případě prodlení prodávajícího s odstraněním vad zboží, uplatněných v záruční době dle čl. VII. odst. 3. této smlouvy, je kupující oprávněn požadovat po prodávajícím zaplacení smluvní pokuty ve výši 0,1 % ze sjednané kupní ceny bez DPH za každý i započatý den prodlení až do podpisu protokolu o odstranění vady.
3. V případě nedodržení termínu splatnosti faktury vystavené prodávajícím, je prodávající oprávněn požadovat po kupujícím úrok z prodlení v zákonné výši z dlužné částky za každý i započatý den prodlení s úhradou faktury.
4. Právo fakturovat a vymáhat smluvní pokutu a úrok z prodlení vzniká kupujícímu prvním dnem následujícím po marném uplynutí doby určené jako čas k plnění a prodávajícímu prvním dnem následujícím po marném uplynutí doby splatnosti faktury.
5. Smluvní pokuty a úrok z prodlení jsou splatné do 30 dnů ode dne doručení písemného oznámení o jejich uplatnění.
6. Smluvní strany se dohodly, že zaplacením smluvní pokuty není dotčeno právo na náhradu vzniklé majetkové či nemajetkové újmy v plné výši, a to tedy i ve výši přesahující vyúčtovanou, resp. uhrazenou smluvní pokutu, a rovněž není dotčeno plnit řádně povinnosti vyplývající z této smlouvy.
7. Smluvní pokutu je kupující oprávněn započíst proti částce fakturované prodávajícím s tím, že kontaktní osoba kupujícího bude o případné výši smluvní pokuty informovat elektronicky kontaktní osobu prodávajícího. Prodávající podpisem této smlouvy uděluje k takovému postupu souhlas.

## IX. Zvláštní ujednání

1. Prodávající prohlašuje, že zboží není zatíženo právy třetích osob.
2. Prodávající potvrzuje, že se plně seznámil s rozsahem a povahou dodávky týkající se předmětu výše uvedené Veřejné zakázky, a že jsou mu známy veškeré technické, kvalitativní a jiné podmínky dodávky.
3. Prodávající se zavazuje zachovávat mlčenlivost ohledně všech skutečností, se kterými se seznámí při plnění této smlouvy. Tato povinnost zavazuje i zmocněnce, zaměstnance nebo jiné pomocníky prodávajícího, kteří se podílejí na plnění této smlouvy.



4. Práva a povinnosti vyplývající z této smlouvy ani celou tuto smlouvu nemůže žádná ze smluvních stran převést anebo postoupit na třetí osobu bez předchozího písemného souhlasu druhé smluvní strany.
5. Obě smluvní strany jsou povinny si bez zbytečného odkladu sdělit písemně veškeré skutečnosti, které se dotýkají změn některého z jejich základních identifikačních údajů nebo kontaktních údajů včetně právního nástupnictví.
6. Smluvní strany vylučují přijetí této smlouvy s jakoukoliv odchylkou, byť by to byla odchylka, která podstatně nemění původní podmínky. Totéž platí i pro sjednávání jakýchkoliv změn této smlouvy.
7. Ustanovení této smlouvy je třeba vykládat v souladu se zadávacími podmínkami k Veřejné zakázce, zejména podmínkami stanovenými v zadávací dokumentaci Veřejné zakázky a v souladu s nabídkou prodávajícího.
8. Kupující je oprávněn, resp. stanoví-li tak právní předpis, povinen, uzavřenou smlouvu zveřejnit v souladu s právními předpisy a prodávající s tímto souhlasí.
9. Proávající se zavazuje spolupůsobit při výkonu finanční kontroly. Podle § 2 písm. e) zákona č. 320/2001 Sb., o finanční kontrole ve veřejné správě a o změně některých zákonů (zákon o finanční kontrole), ve znění pozdějších předpisů, je prodávající osobou povinnou spolupůsobit při výkonu finanční kontroly prováděné v souvislosti s úhradou zboží z veřejných výdajů nebo z veřejné finanční podpory. Proávající se zavazuje stejným způsobem zavázat i svoje poddodavatele.
10. Proávající je povinen uchovávat všechny doklady a dokumenty po dobu a způsobem stanoveným platnými právními předpisy (zákon č. 563/1991 Sb., o účetnictví, ve znění pozdějších předpisů a zákon č. 499/2004 Sb., o archivnictví a spisové službě a o změně některých zákonů, ve znění pozdějších předpisů).
11. Smluvní strany se dohodly, že všechny závazné projevy vůle je třeba činit písemnou formou v listinné podobě a prokazatelně doručit druhé smluvní straně na adresu sídla uvedenou v úvodních ustanoveních této smlouvy s výjimkou případů v této smlouvě uvedených, kdy postačuje elektronická podoba. Pokud smluvní strana, které je písemnost adresována, její přijetí odmítne nebo jiným způsobem zmaří, má se za to, že zásilka odeslaná s využitím provozovatele poštovních služeb došla třetí pracovní den po odeslání, byla-li však odeslána na adresu v jiném státu, pak patnáctý pracovní den po odeslání. Pokud je na doručení druhé smluvní straně vázán počátek běhu doby určené touto smlouvou a smluvní strana, které je písemnost adresována, její přijetí odmítne nebo jiným způsobem zmaří, počíná taková doba běžet následujícího dne po uplynutí třetího pracovního dne ode dne od uložení písemnosti na poštu. Toto však neplatí, využije-li některá ze smluvních stran pro doručení písemnosti datovou schránku ve smyslu zákona č. 300/2008 Sb., o elektronických úkonech a autorizované konverzi dokumentů, ve znění pozdějších předpisů.
12. Kupující deklaruje a prodávající bere na vědomí, že kupující není ve vztazích vyplývajících z této smlouvy podnikatelem.



13. Prodávající odpovídá za újmu vzniklou kupujícímu nebo třetím osobám v souvislosti s plněním předmětu této smlouvy nebo nedodržením či porušením povinností vyplývajících z této smlouvy a zavazuje se ji kupujícímu nahradit.
14. Kupující zadal Veřejnou zakázku v souladu se zásadou environmentálně odpovědného zadávání. Prodávající je povinen, po dodání zboží, na vlastní náklady zajistit odvoz a likvidaci odpadu, a to obalového materiálu dodaného zboží v souladu se zákonem č. 541/2020 Sb., o odpadech, v platném znění.
15. Kupující zadává Veřejnou zakázku v souladu se zásadou sociálně odpovědného zadávání. Prodávající zajistí v rámci plnění této smlouvy legální zaměstnávání osob a zajistí pracovníkům podílejícím se na plnění této smlouvy férové a důstojné pracovní podmínky. Férovými a důstojnými pracovními podmínkami se rozumí takové pracovní podmínky, které splňují alespoň minimální standardy stanovené pracovněprávními a mzdovými předpisy. Kupující je oprávněn požadovat předložení dokladů, ze kterých dané povinnosti vyplývají a prodávající je povinen je bez zbytečného odkladu kupujícímu předložit. Prodávající je povinen zajistit splnění požadavků tohoto ustanovení smlouvy i u svých poddodavatelů. Nesplnění povinností prodávajícího dle tohoto ustanovení smlouvy se považuje za podstatné porušení této smlouvy.
16. Prodávající se zavazuje k řádnému a včasnému plnění finančních závazků svým poddodavatelům, kdy za řádné a včasné plnění se považuje plné uhrazení poddodavatelem vystavených faktur za plnění poskytnutá v rámci Veřejné zakázky, a to vždy do 15 pracovních dnů od obdržení platby ze strany kupujícího za konkrétní plnění.
17. Je-li prodávajícím více dodavatelů v případě společné účasti ve Veřejné zakázce, nesou všichni tito dodavatelé společně a nerozdílně odpovědnost za plnění této smlouvy.
18. Prodávající prohlašuje, že se na něj nevztahují omezující opatření (mezinárodní sankce) přijatá Evropskou unií vůči Rusku a Bělorusku v souvislosti s ruskou agresí na území Ukrajiny. Splnění uvedeného ověřil i u svých poddodavatelů.

## **X. Zánik závazků**

1. Zánik závazků z této smlouvy se řídí příslušnými ustanoveními OZ a touto smlouvou.
2. Smluvní strany se dohodly, že podstatným porušením smlouvy ve smyslu § 2002 odst. 1 OZ se vedle případů specifikovaných v § 2002 OZ rozumí také:
  - a) prodlení prodávajícího s dodáním zboží (či jeho části) a/nebo s jeho zprovozněním či instalací vč. software a/nebo se zaškolením v dohodnutém termínu dle čl. III. odst. 2. této smlouvy delší než 30 kalendářních dnů;
  - b) prodlení kupujícího s uhrazením kupní ceny delší než 30 kalendářních dnů, přičemž prodávající je povinen před odstoupením od smlouvy kupujícího písemně upozornit na neplnění jeho závazků a poskytnout mu přiměřenou lhůtu k nápravě;
  - c) nedodržení sjednaného množství, jakosti nebo druhu zboží;
  - d) jestliže zboží nemá vlastnosti deklarované prodávajícím v této smlouvě či vlastnosti z této smlouvy vyplývající, příp. není v souladu se specifikací zboží;





- e) jestliže prodávající ve své nabídce v rámci Veřejné zakázky, která předcházela uzavření této smlouvy, uvedl informace nebo doklady, které neodpovídají skutečnosti a měly nebo mohly mít vliv na výsledek výběrového řízení;
  - f) nesplnění povinnosti prodávajícího dle čl. IX. odst. 15. této smlouvy.
3. Odstoupení od této smlouvy musí být písemné a nabývá účinnosti dnem doručení tohoto písemného oznámení druhé smluvní straně.
  4. V případě odstoupení od této smlouvy jsou smluvní strany povinny vypořádat své vzájemné závazky a pohledávky stanovené v zákoně nebo v této smlouvě, a to do 30 dnů od právních účinků odstoupení nebo v dohodnuté lhůtě.
  5. Ukončením účinnosti této smlouvy odstoupením od smlouvy nebo jiným způsobem nejsou dotčena práva na smluvní pokuty a náhradu újmy a další závazky, z jejichž povahy vyplývá, že mají trvat i po ukončení účinnosti této smlouvy.

## **XI. Závěrečná ujednání**

1. V otázkách touto smlouvou výslovně neupravených se práva a povinnosti smluvních stran řídí příslušnými ustanoveními obecně závazných právních předpisů platných na území České republiky, zejména OZ a ostatními právními předpisy vztahujícími se k předmětu této smlouvy.
2. Veškeré spory, které se smluvním stranám nepodaří vyřešit smírnou cestou, budou řešeny věcně a místně příslušným soudem České republiky.
3. Tato smlouva bude uzavřena v elektronické nebo listinné podobě, v závislosti na možnostech a dohodě smluvních stran. V případě uzavření v listinné podobě bude vyhotovena ve čtyřech stejnopisech, z nichž každý má platnost originálu a každá smluvní strana obdrží po dvou z nich. V případě uzavření v elektronické podobě bude uzavřena připojením uznávaného elektronického podpisu na straně prodávajícího a kvalifikovaného elektronického podpisu na straně kupujícího. Toto ustanovení se použije obdobně i na případné dodatky této smlouvy.
4. Tato smlouva může být měněna či doplňována pouze písemnými, oboustranně dohodnutými, vzestupně číslovanými dodatky, které se stávají její nedílnou součástí. Za písemnou formu není pro tento účel považována výměna e-mailových či jiných elektronických zpráv. Neplatnost dodatků z důvodu nedodržení formy lze namítnout kdykoliv, a to i když již bylo započato s plněním. Za změnu smlouvy se nepovažuje změna identifikačních či kontaktních údajů.
5. Pokud bude z jakéhokoli důvodu některé ustanovení této smlouvy shledáno neplatným, nečiní tato skutečnost neplatnou celou smlouvu. V takovém případě jsou smluvní strany povinny bez zbytečného odkladu neplatné ustanovení nahradit novým platným, jež bude odpovídat smyslu a účelu této smlouvy.
6. Tato smlouva nabývá platnosti dnem jejího podpisu poslední smluvní stranou a účinnosti dnem jejího uveřejnění v registru smluv podle zákona č. 340/2015 Sb., o zvláštních podmínkách účinnosti některých smluv, uveřejňování těchto smluv a o registru smluv (zákon o registru smluv), ve znění pozdějších předpisů. Případná plnění předmětu této smlouvy poskytnutá před



účinností této smlouvy v souladu s podmínkami této smlouvy se považují za plnění poskytnutá podle této smlouvy.

7. Smluvní strany prohlašují, že si tuto smlouvu přečetly, a že byla ujednána po vzájemném projednání podle jejich svobodné vůle, určitě, vážně a srozumitelně, na důkaz čehož připojují oprávnění zástupci smluvních stran své podpisy.
8. Nedílnou součástí této smlouvy je následující příloha:

Příloha č. 1: Specifikace předmětu plnění

V Pardubicích dne .....  
za kupujícího

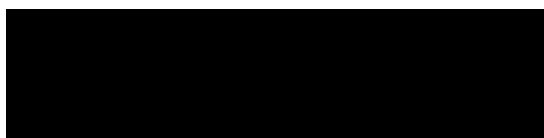

prof. Ing. Libor Čapek, Ph.D.  
rektor

V ..... dne .....  
za prodávajícího

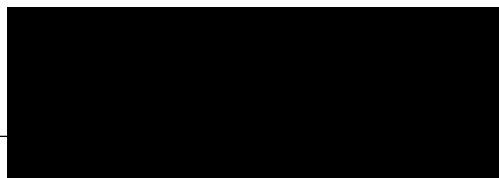

jednatel



Spolufinancováno  
Evropskou unií





## IMPROVE ACCURACY AND REDUCE COSTS

Specim FX10 camera series is designed for industrial and laboratory use. Specim FX10 cameras work in a line-scan mode in the visible and near-infrared (VNIR) area; Specim FX10 in the 400-1000 nm region, and the color optimized Specim FX10c camera in the 400-770 nm region.

Specim FX10 cameras are best suited for:

- Vegetation & agriculture
- Phenotyping
- Color & density in printing
- Display & light source inspection
- Food quality

## FEATURES

- Spectral range of 400-1000 / 400-770 nm
- High spatial resolution of 1024 pixels
- High image speed of 327 FPS (full range)
- Free wavelength selection from 224 bands within the camera coverage
- Built-in image correction
- Unified spectral calibration between units
- GigE or CameraLink standard interfaces
- Easy mounting to industrial environment
- Certificates: CE, RoHS

## SPECTRAL RESPONSE

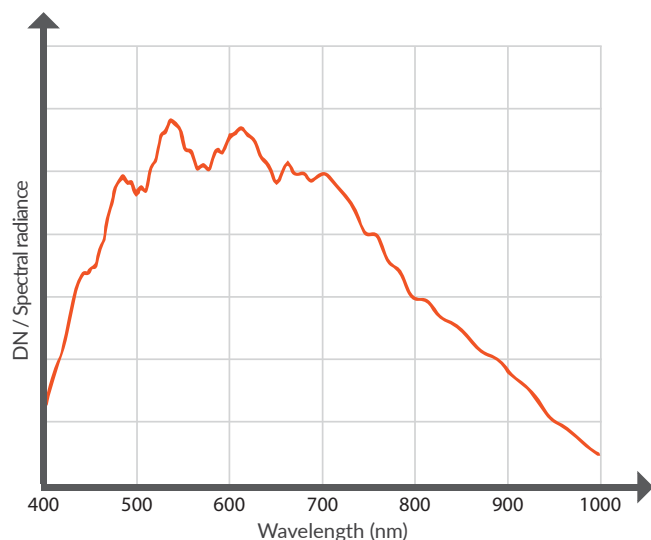

## DIMENSIONS

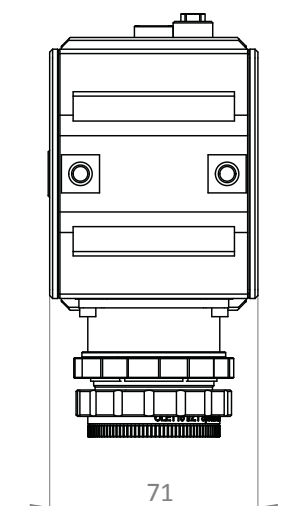
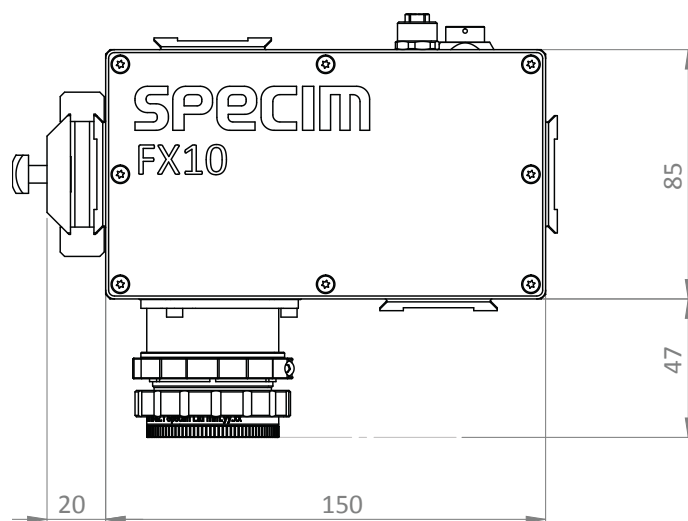

Spectral Range	400-1000 / 400-770 (c-version)	
Spectral resolution (FWHM)	5.5 nm (mean)	
Spectral sampling/pixel	2.7 nm	With default binning
Spectral bands	224 / 140 (c-version)	With default binning
Numerical aperture	1.7	With default lens
Optics magnification	0.80	
Effective pixel size	19.9x9.97 µm	At fore lens image plane
Effective slit width	42 µm	At fore lens image plane
Effective slit length	10.2 mm	At fore lens image plane
SNR @ max. signal	420 : 1	
Spatial samples	1024	
Bit depth	12	
Maximum frame rate	327 FPS full range / 514 FPS full range (c-version)	
Binning	2,4,8 spectral and spatial	Default: 2 spectral x 1 spatial
ROI	Freely selectable multiple bands of interest	Minimum height of ROI is two 1-binned rows. Maximum frame rate is determined by the total number of rows included in the mMROI's
Pixel operability	99.993%	
Image corrections	Non uniformity correction Bad pixel replacement Automatic Image Enhancement (AIE)	One point NUC  AIE: Unified spectral calibration + corrected smile and keystone aberrations
Sensor material	CMOS	
Sensor cooling	Passive	
Full well capacity	90 ke-	
Read-out modes	IWR / ITR	
Optics temperature	Passive	
Lens mount	Custom mount	
Fore lens FOV options	12 deg 24 deg 38 deg (default) 47 deg 51 deg 83 deg	Only the default lens is specifically designed for FX10. With other lens options, optical parameters may vary.
Camera digital data output/control interface	GigE Vision, CameraLink	
Camera control protocols	GenICam, ASCII	
Power input	12 V DC (+-10%)	
Power consumption	Max 4 W	
Connectors	Industrial Ethernet OR CameraLink 26-pin, 0.5" MDR	
IP	IP52	
Dimensions (L x W x H)	150 x 85 x 71 mm	Mounting surface option on three sides. Mounting kit adds 24 mm distance on mounting side.
Weight	1.3 kg	
Storage temperature	-20 ... +50°C (non-condensing)	
Operating temperature	+5 ... +40°C (non-condensing)	
Relative humidity	5% – 95% (non-condensing)	

Specim, Spectral Imaging Ltd. ▪ A Konica Minolta Company ▪ POB 110, FI-90591 Oulu Finland ▪ Elekroniikkatie 13, Oulu Finland  
Tel +358 (0) 10 4244 400 ▪ VAT Identification number FI10079234 ▪ info@specim.com ▪ www.specim.com

Information in this document is subject to change without notice. Specim, Spectral Imaging Ltd. reserves the right to change or improve its products and specifications and to make changes in content without obligation to notify any person or organization of such changes or improvements.

# LabScanner 40x20



## A VERSATILE DESKTOP SPECTRAL IMAGING SYSTEM

Specim LabScanner 40x20 is a small scanner for laboratory use. It has a 400x200 mm sample tray, a mount for a camera, halogen illumination and optional camera height adjustment. The scanner can be ordered with a Dual Illumination unit. The scanner is controlled through the spectral camera or with a separate control cable using Specim's LUMO Scanner Software Suite.

## COMPATIBILITY

Specim LabScanner 40x20 is designed for the following cameras:

- Specim FX10
- Specim FX17
- SWIR (Note! SWIR camera cannot be powered using the scanner's power out connector)

## DIMENSIONS

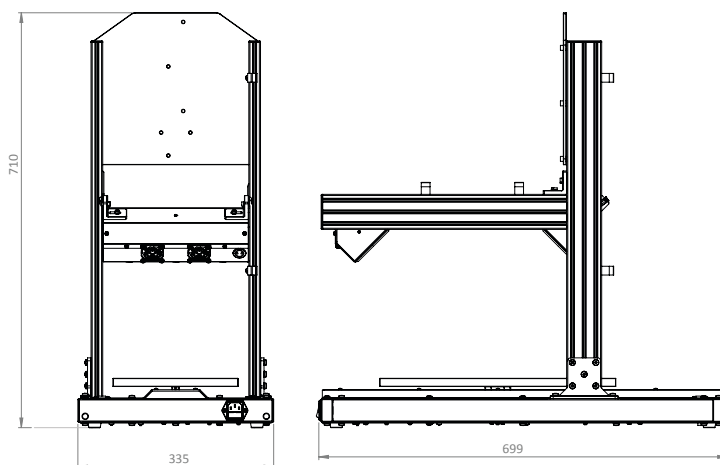

Size (L x W x H)	699 x 335 x 710 mm
Camera height adjustment	Optional, 200 mm
Sample tray dimensions	400 x 200 mm
Weight	13 kg +/- 10 %
Max sample weight	5 kg
Scanning speed	0,1 mm/s – 99 mm/s
Control interface	Through spectral camera or with separate control cable (USB or RS232)
Illumination	DECOSTAR 51 ALU 20W 12V 36deg GU5.3 halogen
Input voltage	Nominal 100...240 VAC
Output voltage	12V DC
Output current	26.7 A
Max power consumption (incl. scanner motor, illumination, FX17)	Single illumination: 110W Dual illumination: 170W

# SPECIMINSIGHT

SpecimINSIGHT is an off-line software tool that allows users to browse and explore hyperspectral data, create and validate classification models. The models created with SpecimINSIGHT can be deployed on SpecimCUBE computing platform for real-time data processing.

## TURN HSI DATA QUICKLY INTO APPLICATIONS

- Explore and analyse hyperspectral data
- Train qualitative and quantitative prediction models
- Apply the models on SpecimCUBE for real-time data processing

## TECHNICAL DETAILS

Supported O/S	Windows 10 64bit
Minimum PC requirements	Intel i3 or equivalent 4GB of RAM At least 256GB hard drive Intel HD series GPU
Recommended PC requirements	Intel i5 or equivalent 8GB of RAM CUDA v10 compatible GPU for faster offline processing SSD drive instead of HDD for faster data loading
Supported data format	ENVI
Features	<ul style="list-style-type: none"> <li>• Various plotting tools (spectral, spatial, scatter, time series)</li> <li>• Various selection tools (single point, rectangle, ellipse, brush, lasso, magic wand)</li> <li>• Principal Component Analysis (PCA)</li> <li>• Spectral similarity tool (SAM)</li> <li>• Hyperspectral calculator</li> <li>• Color measurement tools</li> <li>• Qualitative analysis with PLS-DA</li> <li>• Quantitative analysis with PLS</li> <li>• Preprocessing options : Derivative, Normalization (p-Norm, max-Norm), Mean-centering, Savitzky-Golay smoothing, Standard Normal Variate (SNV)</li> <li>• Creating new datasets with mosaicing</li> <li>• Annotating data</li> <li>• Real-time data processing with SpecimCUBE</li> <li>• Tools to measure statistics on spectra and their band selections and to create selections based on the statistics.</li> </ul>



# SPECIMINSIGHT

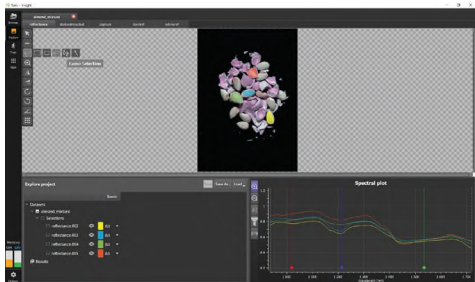

## BROWSE AND VIEW HYPERSPECTRAL DATA

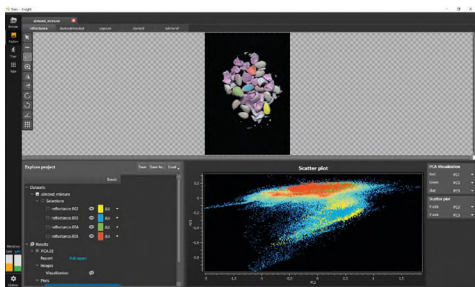

## EXPLORE AND ANALYZE HYPERSPECTRAL DATA

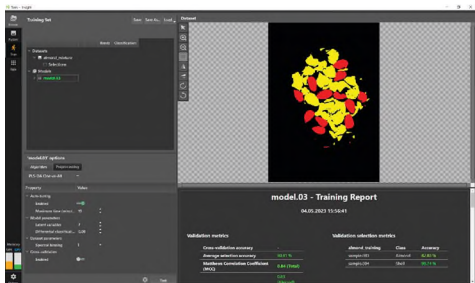

## CREATE CLASSIFICATION MODELS BY TRAINING AND VALIDATION



## APPLY

- Transfer the classification models created with SpecimINSIGHT to SpecimCUBE and apply them for real-time data processing.
- Suitable for both industry and research applications inline, at-line, and in the laboratory.
- Sorting, quality inspection, and process optimization.
- Analysis, quantification, and monitoring of nutrients, moisture, protein, sugar, fat, pH values, etc.

Specim, Spectral Imaging Ltd. ▪ A Konica Minolta Company ▪ POB 110, FI-90591 Oulu Finland ▪ Elektriikkatie 13, Oulu Finland  
Tel +358 (0) 10 4244 400 ▪ VAT Identification number FI10079234 ▪ info@specim.com ▪ www.specim.com

Information in this document is subject to change without notice. Specim, Spectral Imaging Ltd. reserves the right to change or improve its products and specifications and to make changes in content without obligation to notify any person or organization of such changes or improvements.

# CAMMC134x Camera Reference Guide V 2.0





## Table of Contents

<b>About This Reference Guide .....</b>	<b>4</b>
Remarks, Notes and Warnings.....	4
Registered Trademarks .....	4
Warranty and Non-Warranty Clause .....	5
<b>Conformity and Use of the Product .....</b>	<b>6</b>
Supplements .....	7
<b>EU Declaration of Conformity.....</b>	<b>8</b>
<b>Hardware .....</b>	<b>9</b>
Scope of Delivery .....	9
Identification Plate.....	10
Interfaces and Buttons.....	11
Power and Camera Status LEDs .....	11
Power Supply .....	13
Charging the Battery .....	13
Standby Mode.....	14
<b>Installation of the Camera.....</b>	<b>15</b>
<b>Connecting External Signals.....</b>	<b>16</b>
Digital 4/Trigger and SyncIN .....	16
Analog Input Signal Definition .....	16
Digital Inputs 1-3 Signal Definition.....	16
Sync/ARM Output .....	16
SYNC OUT / ARM Output Signal Definition .....	17
<b>Configuration.....</b>	<b>18</b>
Commands .....	18
Frame Memory Overview .....	18
Write Pointer/Counter .....	18
Memory Registers .....	19
Memory Write Register :R1 .....	20
Memory Pointer/Counter Register :R2 .....	21
Memory Read Register :R3[31...30] = 0 .....	22
ExposureTime Register :R3[31...30] = 4 .....	23
FrameRate Register :R3[31...30] = 8 .....	24
Read Single Memory Registers .....	24
Read All Analog Registers.....	25

Sensor Commands .....	25
Sensor Registers.....	26
Image Quality .....	28
Image Size and Position .....	29
Clock Selection .....	31
Image Format Change.....	31
Image Speed.....	32
Exposure Time.....	32
ImageBLITZ Trigger.....	33
Digital Gain.....	33
Test Image.....	34
Profile Processing.....	34
Read Serial Number, Firmware Revision and Model .....	35
Read Extended Camera Identifier .....	37
Read Camera Settings .....	38
Image Information Field.....	39
Memory Information Field.....	39
Free Text .....	39
IRIG-B .....	40
Firmware .....	42
<b>Assigning an IP Address.....</b>	<b>43</b>
Working with Several Network Cards .....	45
<b>Mount an F-Mount Adapter .....</b>	<b>46</b>
<b>Maintenance .....</b>	<b>47</b>
Cleaning the Lens .....	47
Cleaning the IR-filter .....	47
Changing the Battery .....	47
<b>Technical Data .....</b>	<b>48</b>
<b>Pin Assignments.....</b>	<b>49</b>
Power Connector .....	49
Trigger Connector .....	49
<b>Spectral Response of CAMMC134x .....</b>	<b>50</b>
<b>Dimensions.....</b>	<b>52</b>

## About This Reference Guide

---

This reference guide is written for the experienced programmer and systems integrator. It provides all information about the features of the high speed CAMMC134x (Cube4) camera in order to integrate the camera into a system. This manual does not cover the installation and the explanation of the driver software on the Host PC. This is covered in the Director 2 Software Manual.

Although this description has been produced with care, it can neither be complete nor be free of errors. MIKROTRON GmbH cannot be held legally responsible for any errors or missing information in this description. In case problems occur, please contact our service team:

Email: [info@mikrotron.de](mailto:info@mikrotron.de)

Phone: +49 - 89 - 7263 4243

This description is subject to change without notice.

## Remarks, Notes and Warnings

This description contains remarks, notes and warnings that are helpful and often important to avoid data loss or camera damage. They are emphasized as follows:

### Remark

Provides hints and helpful information



### Note

Hints concerning frame quality or timeouts and other helpful information



### WARNING

Important information concerning data loss or camera damage

It is quite unlikely that personal damage will occur by using the 12V-cameras described. Therefore a fourth grade warning is not to be found.

## Registered Trademarks

In this description the following product names are registered trademarks:

- MotionBLITZ®
- Microsoft®
- Microsoft Windows®

In the following, these product names are not specially marked as registered trademarks. This does in no way imply that these product names may be used freely.

## Warranty and Non-Warranty Clause

Warranty is described in §8 of our General Terms and Conditions which can be downloaded on MIKROTRON'S webpage: <http://www.mikrotron.de/en/terms.html>

In addition, take the following non-warranty clauses into account.



### WARNING

- The camera does not contain serviceable parts. Do not open the body of the camera. If the camera has been opened, the warranty will be void.
- The camera may only be used with a supply voltage according to the camera specification. Connecting a lower or higher supply voltage, AC voltage, reversal polarity or using wrong pins of the power connector may damage the camera. Doing so will void warranty.
- Our warranty does not protect against accidental damage, loss, or acts of nature.
- MIKROTRON cannot be held responsible for the loss of data. We recommend a backup plan.



Necessary information to fill in the RMA form on the identification plate of the camera

Before sending back the camera, ask for a RMA number and form either by

- phone: +49 - 89 - 7263 4250 or by
- email: [info@mikrotron.de](mailto:info@mikrotron.de)

Write down the camera type and serial no. and send the camera back to your distributor. If no distributor is available, send it back to MIKROTRON (☞ page 54).

## Conformity and Use of the Product

---

This equipment has been tested and found to comply with the limits for a Class A digital device, pursuant to Part 15 of the FCC Rules. These requirements are designed to provide reasonable protection against harmful interference when the equipment is operated in a commercial environment.

This equipment generates, uses, and can radiate radio frequency energy and, if not installed and used in accordance with the instructions given in this reference guide, may cause harmful interference to radio communications. Operation of this equipment in a residential area is likely to cause harmful interference in which case the user will have to correct the interference at its own expense.

**Remark:** You are herewith cautioned that any changes or modifications not expressly approved in this reference guide could void your authority to operate this equipment.

制造说明:

此设备的生产与测试依照FCC条例第15条条例，符合A类电子设备标准。产品提供在商用使用环境中的合理保护，以防止使用过程中可能涉及到的损害。

此设备会产生、使用并可发射出无线电波，如果未按照本手册中所述安装和使用，可能会对无线通信设备产生干扰。如本设备在居民区操作出现干扰等情况，用户需要自费处理。

备注：请注意，如未按照此使用说明操作而自行更改设备，那么您将无权使用本设备。

規制適合宣言とご使用について (米国FCC)

この機器は、FCC規則のパート15に定められたクラスAデジタル装置に関する規制要件に基づいて所定の試験が実施され、その適合が認証されています。これらの規制要件は、商業環境において機器を使用する際、有害な干渉に対する妥当な保護を提供するために設けられています。この機器は、無線周波数エネルギーを生成かつ利用するとともに、放射することもあります。このリファレンスガイドの指示に従って設置および使用が行われない場合は、無線通信に有害な干渉を引き起こす恐れがあります。この機器を住宅地で利用すると有害な干渉を起こすこともあり、その場合、使用者は自己負担において適切な対策を講じる必要があります。

注意事項： このリファレンスガイドに明示的に承認していない変更や修正を行った場合には、本製品を使用する権利が無効となることがあります。

## Supplements

### For customers in Canada

This apparatus complies with the Class A limits for radio noise emissions set out in Radio Interference Regulations.

### Pour les utilisateurs au Canada

Cet appareil est conforme aux normes Classe A pour bruits radioélectriques, spécifiées dans le Règlement sur le brouillage radioélectrique.

### Life Support Applications

The products described in this reference guide are not designed for use in life support appliances, or devices and systems where malfunction of these products can reasonably be expected to result in personal injury.

MIKROTRON customers using or selling these products for use in such applications do so at their own risk and agree to fully indemnify MIKROTRON for any damages resulting from such improper use or sale.

## EU Declaration of Conformity

---

Mikrotron  
 Mikrocomputer, Digital- und Analogtechnik GmbH  
 Landshuter Str. 20 - 22  
 D-85716 Unterschleissheim  
 www.mikrotron.de

Phone: +49 (0)89 72634200  
 Fax +49 (0)89 726342-99  
 Mail: [info@mikrotron.de](mailto:info@mikrotron.de)

**We herewith declare under our sole responsibility that the products mentioned below:  
 Hiermit erklären wir in alleiniger Verantwortung, dass die folgenden Produkte:**

Camera type: MotionBLITZ EoSens  
 Kameratyp: MotionBLITZ EoSens

Models: CAMMC134x  
 Modelle: CAMMC134x

**are in conformity with the following EU directives:  
 den folgenden EU-Richtlinien entsprechen:**

Title / Titel	EU Directive / EU-Richtlinie
RoHS Directive on the Restriction of the Use of Certain Hazardous Substances in Electrical and Electronic Equipment  RoHS-Richtlinie zur Beschränkung der Verwendung bestimmter gefährlicher Stoffe in Elektro- und Elektronikgeräten	2011/65/EU
Approximation of the laws of the Member States relating to electromagnetic compatibility and repealing Directive 89/336/EEC  Angleichung der Rechtsvorschriften der Mitgliedstaaten über die elektromagnetische Verträglichkeit und zur Aufhebung der Richtlinie 89/336/EWG	2004/108/EC  2004/108/EG

**During conformity-testing the following standards were consulted:  
 Die Konformitätsvermutung wurde nach folgenden Standards überprüft:**

Title / Titel	EU Standard / EU-Norm
Information technology equipment - Immunity characteristics - Limits and methods of measurement  Einrichtungen der Informationstechnik – Störfestigkeitseigenschaften - Grenzwerte und Prüfverfahren	EN 55024:1998 + A1:2001 + A2:2003
Information technology equipment - Radio disturbance characteristics - Limits and methods of measurement  Einrichtungen der Informationstechnik – Funkstöreigenschaften - Grenzwerte und Messverfahren	EN 55022:2006 + A1:2007

Unterschleissheim, May 6, 2015  
 Unterschleißheim, den 06.05.2015

Dipl.-Kfm. Christian Pilzer

## Hardware

---

The CAMMC134x (Cube4) is a high speed CMOS camera with a resolution of 1280 x 1024 pixels. It provides up to 4 GByte of internal memory. Benefits of CMOS technology are high speed random access to pixels with free programmability and low power consumption.

An internal NiMh battery allows video recording at 1000 fps and 1280 x 1024 pixels of resolution for more than one hour. If the camera is not connected with an external power supply, data of stored image sequences will be available for a few hours. Video data is accessible by the build-in Gigabit high speed serial interface.

The camera is provided with an industry standard c mount adapter which can easily be exchanged for an f mount lens adapter. The sensor diagonal amounts to 1.25" with square pixels measuring  $12 \mu\text{m}^2$ .

Before exposure starts, the content of all light sensitive elements is deleted. After exposure, the accumulated charge is transferred to an analog memory associated with each pixel where it is stored until it is read out (and discharged) by the A/D conversion cycle. As all light sensitive elements are exposed at the same time, even fast moving objects are captured without geometric distortion.

The internal frame memory consists of up to two DDR2 RAM boards, each with 4 GByte. Total memory capacity amounts to max. 8 GByte.

All CAMMC134x color cameras use a Bayer filter for color separation.

## Scope of Delivery

Please check whether the delivery is complete, before you start to install the camera:

- ✓ Camera CAMMC134x (Cube4)
- ✓ C-Mount Lens
- ✓ Mikrotron Support CD
- ✓ 1 power supply 12 VDC; 1.25A min.
- ✓ 1 power cable



## Identification Plate

The identification plate of your camera shows the:

- camera name (EoSens Cube4)  
CAMMC134x
- serial number (in this example: S/N 00111)



- MAC No. (00-11-1C-F1-74-32) stands for Media Access Control address which is the unique hardware address of the network adapter. This address will be used as identifier in networks.
- Invisible optional features are listed under options with the following abbreviations:

Abbreviation	Meaning
C	color
HG	High-G: ruggedized version shock: 100g; vibration: 10g at 5 to 2500 Hz
IB	ImageBLITZ option
IG	IRIG-B input processing option
M6/M11/M13	extended buffer size
MS	multi sequence mode
PR	power on recording
SB	standby

- Voltage: allowed voltage DC 10.5 – 30 V

## Interfaces and Buttons

One side of the CAMMC134x camera provides 3 connectors, 2 buttons and several LEDs (☞ page 12). The pin assignments of the connectors are described on page 49.

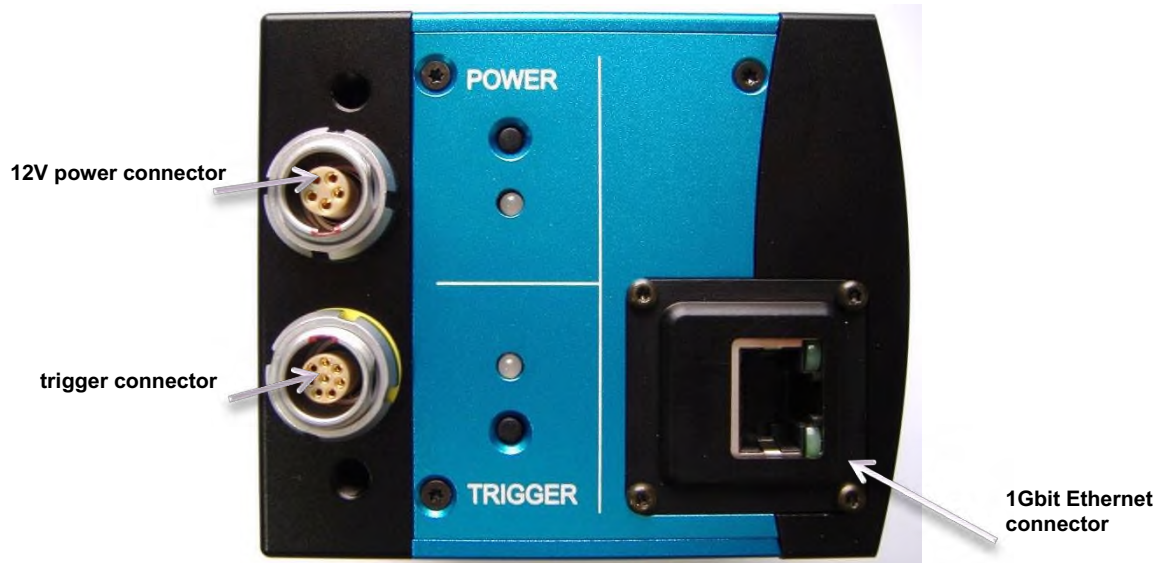

Figure 1: Connectors and GigE-Interface of the Cube camera

If you switch on the camera, it will take a few seconds until it will be ready for high speed recording at full resolution. As this camera is equipped with a rechargeable battery, a connection to the PC will only be needed for downloading recorded sequences or modifying camera parameters.

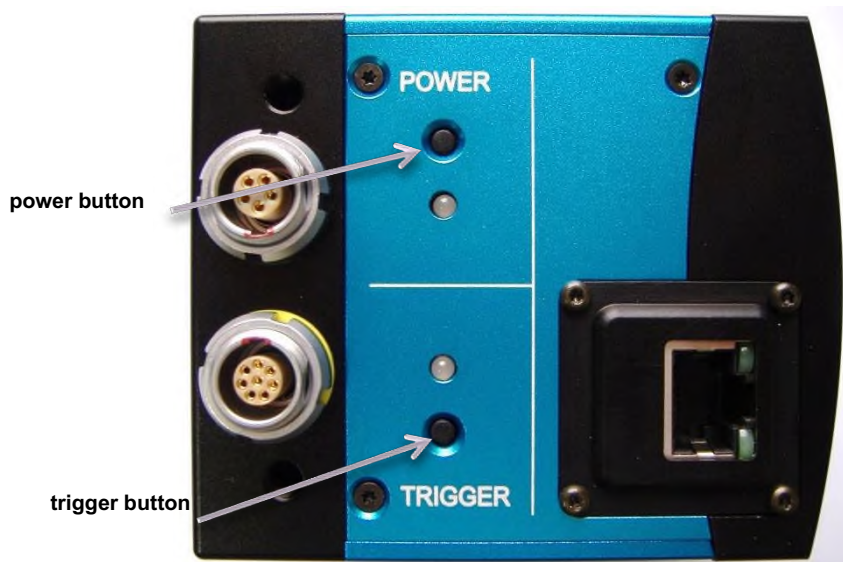

Figure 2: Buttons and LEDs of the camera

**Remark:** For more information about the pinning of the power and trigger connector ☞ page 49.

## Power and Camera Status LEDs

The CAMMC134x can be operated with the internal NiMh battery and/or an external DC supply providing 10.5 ... 30 V @ 10 Watt max.

The power LED indicates the power status:

Color	LED status	Power supply
For cameras supporting the standby function:		
RED/ ORANGE	flashing	Standby mode with external power supply
GREEN	flashing	Switched on, with internal power supply (battery)
Color	LED status	Camera/battery status
OFF	dark	camera is switched-off, battery will not be charged
RED	constant	camera is switched-off, battery charging in progress
GREEN	constant	camera is switched-on, no charging (battery full or no power supply connected)
ORANGE	constant	camera is switched-on, battery charging in progress

**Remark:** In case the batteries are empty, it will take a few minutes of initial charging before the camera can be switched on.

The internal NiMh battery has a capacity of 2.2 Ah and is charged automatically within three to four hours if an external power supply is available. If the camera is operating and external power is applied, the battery will be charged.

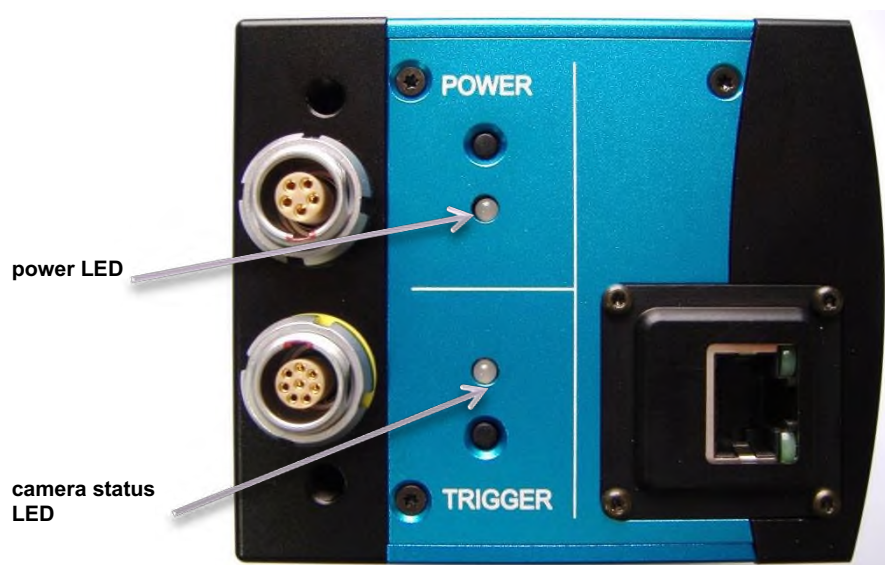

The camera's status LED indicates the actual operating status.

Color	LED state	Operating state
OFF	-	power OFF, no communication
RED	flashing	power ON, new firmware will be loaded
RED	constantly	FPGA configuration failed, consult our service team
ORANGE	after power ON 3 sec	FPGA configuration is in progress
GREEN	constant	ready for the first recording after power-up
ORANGE	flashing	circular recording in progress
ORANGE	constantly	circular recording stopped

## Power Supply

CAMMC134x cameras come with an external power supply. Connect it with the power connector of the camera in order to charge the battery and/or to operate the camera in case battery status is low.

### WARNING

#### Serious Camera Damage



- Only a maximum voltage of 10.5 to 30 V @ 10 W is permitted. Higher input voltages may seriously damage the camera. Damages caused by supplying the wrong voltage are not covered by warranty.
- The battery of CAMMC134x camera is equipped with an additional fuse and a temperature probe. Therefore, never change the battery yourself! Instead, contact our service team and ask for a RMA number [info@mikrotron.de](mailto:info@mikrotron.de) and send the camera back to MIKROTRON. Damages caused by battery change are not covered by warranty.

Although each camera comes with a power supply, the power connector pinning of the 5-pin Lemosa might be helpful e.g. when cables have to be extended. Please, refer to page 49.

## Charging the Battery

CAMMC134x cameras are equipped with an integrated, rechargeable battery. It provides the necessary voltage for operation and will automatically be charged as long as the power supply is connected with the camera and the camera is switched off. Charging a completely empty battery will take about three hours.

If the batteries are charged, the camera can be disconnected from the PC and will record autonomously.

#### Remarks:

- If the battery is completely charged, the green Power LED will signal it by a quintuple blinking. If the battery is empty, the LED will indicate it by a single blinking.

- If the camera is switched-on and a power supply is connected, battery charging will be very slow. Nevertheless, the camera might operate in stand-alone mode for a few minutes after being disconnected from the power supply.
- In order to charge the battery completely, connect it with the power supply and switch the camera OFF.
- A completely charged battery will discharge within a few days if not used. If the battery is completely charged,
  - + CAMMC134x cameras will record in ring mode for up to 60 minutes at full resolution without power connection
  - + recorded images can be kept in the camera for up to 24 hours if *Standby after Record* is set

## WARNING



### Data Loss

**If the battery status is unknown, make sure to connect the external power supply. If the battery is discharged, recording will be stopped. In this case all recorded frames will be lost.**

## Standby Mode

Without an external power supply, frames will be kept for up to 24 hours if the CAMMC134x camera is in standby mode (optional feature). This is achieved by switching OFF several components of the camera's electronics. In standby mode, only the image memory will be supplied with power. That is why you do not have access to the image memory in standby mode.

### Procedure:

1. In order to change into standby mode, press the power switch for less than 1 second
2. In order to change into operating mode, again press the power switch for less than 1 second



## WARNING

### Data Loss

**If you press the power button longer than 1 second, the camera will be shut down completely and all recorded frames will be deleted.**

If a CAMMC134x camera is in standby mode, the Status LED will be OFF and the Power LED will be flashing.

**Remark:** A camera in standby mode has to be connected with the power supply before waking it up.

## Installation of the Camera

Only a few steps are needed to install MotionBLITZ EoSens cameras.

**Remark:** In multi-camera mode we recommend to connect all cameras via a switch with the Ethernet card of your PC.

**NOTICE** The camera must only be connected to non-PoE network cards. Connecting a PoE network card damages the camera board.

### Procedure:

1. **Install all drivers and support software on your image processing system**
2. **Make sure that your network card has been installed properly** (☞ manual of your network card)
3. **Take off the cover of the cameras' sensor and mount the lens**  
In case an f-mount lens has to be mounted ☞ page 46.
4. **Connect the power supply first with the camera, then with the main supply**  
The status LED lights orange and becomes green after a few seconds.



### WARNING

#### Camera Damage

Connect only the power supply NTCAM137XL or a power supply with exactly the same technical data and pinning.

Connecting a wrong power supply might damage the camera!

5. **Connect the shielded Gigabit Ethernet cable first with the camera, then with your PC**

The data transfer status is indicated by the upper data transfer LED:

	LED Color	Data transfer
	orange	data transfer in progress
	green	data transfer at 1 Gbit

**Remark:** Normally, an IP address will be assigned automatically. This may take a few minutes. In case you want to accelerate this process or in order to assign a certain IP address (☞ page 18).

## Connecting External Signals

When applying external signals, e.g. to trigger events or synchronize one or more cameras it is important to know the internal circuits of the CAMMC134x camera.

### Digital 4/Trigger and SyncIN

The Digital Input 4/ Trigger and the Sync Input are isolated from the rest of the circuitry by an optical coupler. The pull-up resistors R33/R32 are powered by an internal DC/DC converter (X3.3V). The optical coupler will switch if the input is connected to the common GND signal (pin 1 on signal I/O connector).

A positive edge on the SYNC input will output the next image, if the positive “Sync edge” is selected in the camera menu (:rf[3] = 0/1 = pos/neg edge).

A positive edge on the Trigger input will stop a circular recording if the positive “Trigger edge” is selected in the camera menu (:r7[8]).

The trigger input is debounced with 100 ms retrigger suppress time.

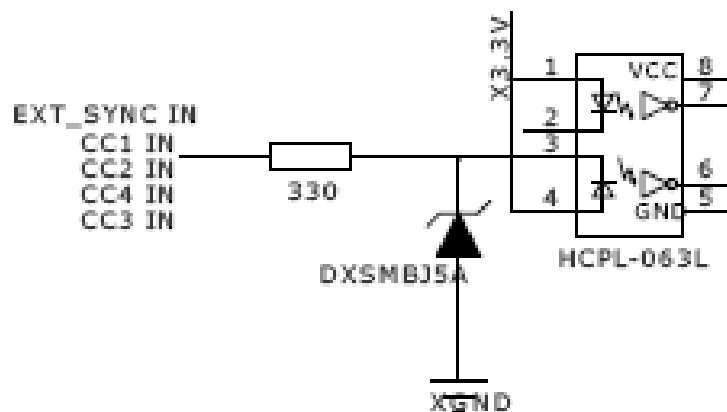

### Analog Input Signal Definition

The analog input is protected by a 330kΩ series resistor and adjusted to deliver the digital value of 255 for 2.55V input voltage.

### Digital Inputs 1-3 Signal Definition

The signals DIG IN1-3 are TTL input signals and are used as process signals, which are superimposed to the image.

### Sync/ARM Output

According to the settings in the Camera IO menu of VisualMARC, this pin will either output a Sync or an ARM signal. If Sync out is selected, this output will carry a strobe that corresponds to the selected exposure time of the camera. If ARM is selected, it will be active when the camera runs in Ring Mode and is recording.

## SYNC OUT / ARM Output Signal Definition

This pin can output a SYNC OUT signal or an ARM signal, which can be selected by switching register bit rf[1]. If SYNC OUT is selected, this output will carry a strobe that corresponds to the selected exposure time of the camera. If ARM is selected, it will be active if the camera runs in circular recording mode.

Four CMOS inverters are paralleled to drive transmission lines with 50 OHMs impedance. The inverters are supplied with an isolated power supply. The output polarity is positive when the selected signal is active. The suppressor diode protects the output against reverse voltages. It starts conducting if the voltage at the output pin is greater 6V.

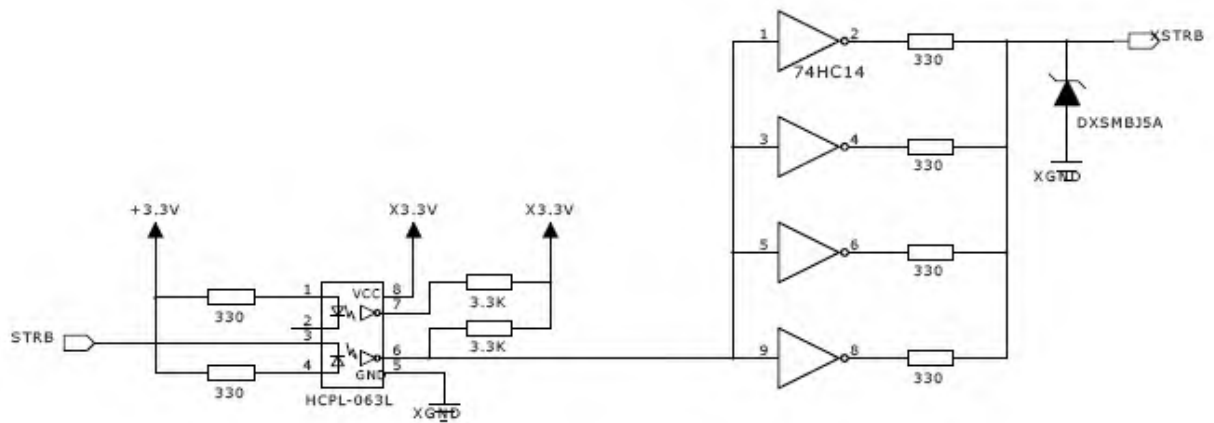



## Configuration

---

The CAMMC134x camera has several registers:

Register	Number	Width
sensor registers r1 .... r <sub>n</sub>	15	10 bit
D/A registers a1....a8	8	8 bit
random clock select registers	2	6 Bytes
memory control registers	3	32 bits

The content of all registers is called a profile and can be stored into a non-volatile memory.

Any change of a specific register via the serial interface will immediately be processed and written into the volatile part of the memory. Its content will get lost when power is OFF. A command has to be used to store the actual setting of the power-up profile in the non-volatile memory. After power-up the PowerUpProfile is loaded from the non-volatile memory into the volatile part of the memory.

**Note:** All values are given in hexadecimal notation, e.g.: 0xff or 0ffh = 255 dec.

## Commands

Commands to change camera settings are ASCII strings. They all start with a colon, followed by one command character and a value in hexadecimal notation with as many ASCII characters as required by the command (2....8 characters).

**Note:** All alphabetic characters in commands are case-sensitive.

After a command has been recognized it will be processed immediately. This applies to all commands except the save type commands (e.g. :pc). The execution of these commands require EEPROM write time depending on the quantity of data, but at least some 10 ms. An answer is provided with the read type commands (:v, :w, :W, :z). In case the command “command acknowledge flag” is set, the answer will be an ACK or NAK. Wrong commands will not be processed. Processing is stopped immediately after recognizing the error.

## Frame Memory Overview

There are two independent pointers with three associated counters. The write pointer with its counter and an independent trailer counter controls writing to memory. The read pointer controls reading. All pointers and counters use OctoWORD (16 Bytes) entities.

Writing and reading can be done simultaneously up to a total bandwidth of approximately 1.5 GBytes/s. Reading bandwidth is limited to 66 MBytes/s.

## Write Pointer/Counter

The write pointers start address is programmed in register :R2[0,29...0] and its length in :R2[8,29...0]. Writing to memory can be done continuously because the write pointer wraps automatically to its programmed start address when the write counter has expired (ring memory).

Even if continuous writing is selected (:R1[1] = 1), this bit can be cleared at any time by stopping writing on an expired write or trailer counter.

If single writing is selected, writing to an expired write or trailer counter will automatically be stopped.

Multiple ring operation is possible with :R1[31...28]. It has to be set according to the :R1 bit description. The figure below shows a two ring operation.

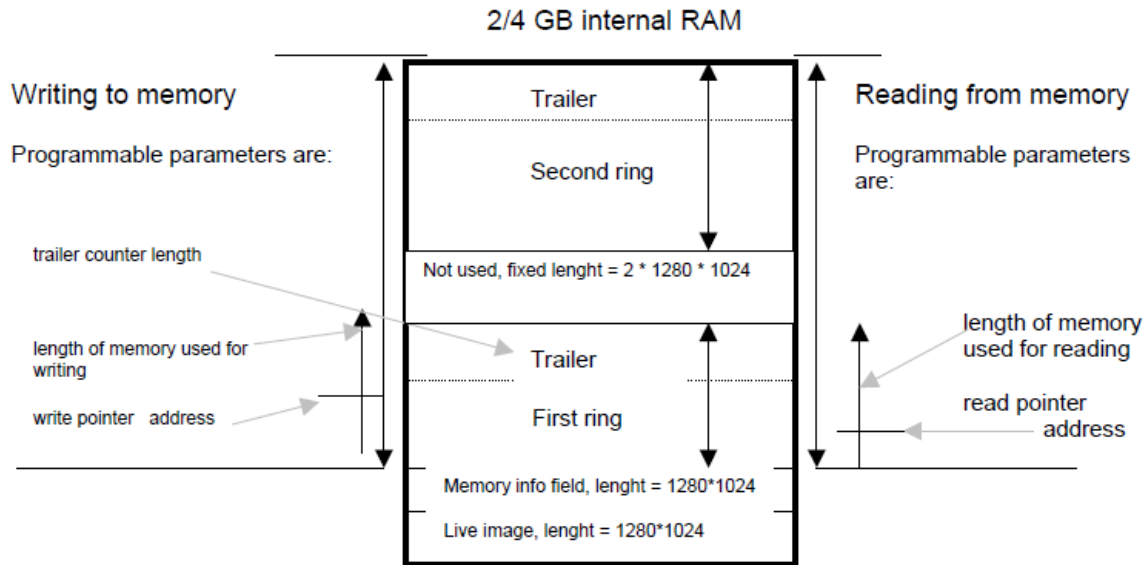

The camera will continuously write into the first ring (1/2 of memory) until :R1[1] is lowered and the trailer counter expired. Then frames are automatically written into ring2 until :R1[1]=0. At that time memory control logic will lower :R1[0]. The control program will continuously poll :R1[0] to insure that :R1[1] will not be raised again if :R1[0] = 0.

### Trailer Counter

The trailer counter can count in parallel with the write counter, if selected. If selected (:R1[27] = 1), it will stop writing as soon as it is expired. This is useful if a continuous writing procedure is interrupted by an external signal but a previously defined number of frames should be recorded after the signal came in (a “trailer” should be written).

### Memory Registers

Memory is organized in 8 WORDS (16 Bytes). Its address is a linear physical address that starts with 0 and ends at 0x1FFFFFFF. A memory board provides 2 GByte. CAMMC134x cameras can be equipped with two memory boards providing 4 GBytes altogether (see also :v command for camera identifier and memory size).

Use the capital letter :R in order to program the memory register.

## Memory Write Register :R1

Register 1 is the memory control register which defines the size of the memory, the image size (line length, no. of lines per image), and the image mode (live image, circular or non-circular recording) as well as some control bits. It can be read at any time with the command :z1. Its content consists of eight ASCII characters.

Syntax	Bits	Value	Description	
:R1<xxxxxxxx> xxxxxxxx = 8 ASCII hex characters	0	0 1	stop write memory write frames to memory (address = R20xxxxxxxx, length = :R28xxxxxxxx)	
	1	0 1	write frames to memory address non continuously write frames to memory continuously	
	2	0 1	dual die 2 Gbit RAMs single die 1 or 2 Gbit RAMs	
	3	0 1	2 Gbit RAMs 1 Gbit RAMs	
	4	0 1	normal operation reset logic, but not registers	
	6...5	00 01 02	RAM size: 2 GByte 4 GByte 8 GByte	
	7	0 1	normal operation select internal grey scale camera: linelen = :1+R1[15...8] [8words] numlin = 1+R1[27...16] [lines]	
	15...8	0x4F...1	linelen = 1+:R1[15...8] [8words]	
	25...16	0x3ff...1	numlin = 1+R1[27...16] [lines]	
	26	0 1	write wrap indicator (read only): cleared when start write issued Set when write memory counter (:R2[8]) has reached its end position	
	27	0 1	no standby after end of recording sequence request standby mode after end of recording sequence	
	30...28	0...4	select number of rings: value 0,1,2,3 = 2,4,8,16 rings	
		31	0 1	single ring multiple rings

bits 1...0 select mode of write operation:

If :R1[1...0] = 1, frames of total length = :R2[8,29...0] are written to memory address :R2[0,29...0]. Bit 0 is cleared automatically on completion of this action.

If :R1[1...0] = 3, frames of total length = :R2[8,29...0] are written to memory address :R2[0,29...0] continuously.

If bit 1 is cleared while writing continuously, the current write action will be continued until :R2[8,29...0] is expired. Writing will stopped and bit 0 cleared automatically.

bits 3...2 are selected according to the extended camera identifier retrieved with the command :V and should be set to the same value as read with :z1 after power up of the camera. Please pay attention: the bits in :R1 are not the same as in :V response!

bit 4 can be cleared/set if a reset of memory control logic is required.

- bits 6...5 select the memory size: 0=2GByte, 1=4Gbyte, 2=8Gbyte, must be initialized by control program on power up. Other settings are not allowed and will be ignored.
- bit 7 selects an internal grey scale camera simulation. This can be used to fill memory with a known pattern.
- bits 15...8 selects an x-counter *linelen* to generate internal LVAL signals that are necessary for the Gbit interface.  
Calculate this value according to:  $:R1[15...8] = r5-r4$
- bits 25...16 selects a y-counter *numlin* to generate internal FVAL signals that are necessary for the Gbit interface. Calculate this value according to:  
 $:R1[25...16] = r3$
- Note:** *linelen* and *numlin* are used only with the Gbit Ethernet interface. The length of video data stored in the memory is defined by  $:R2[8,29...0]$ . Make sure that  $:R2[8,29...0]$  is a multiple of  $linelen+1*numlin+1$ .
- bit 26 is read only and indicates that the write counter has expired once. It is cleared by toggling the write enable bit, e.g.: by restarting write. ( $:R1[0]$ )
- bit 27 Request standby mode after end of recording sequence. Works together with the  $:k1$  command
- bit 28...30 select number of rings in multiple ring operation: 0...4 = 2, 4, 8, 16 rings.
- bit 31 selects multiple ring operation.

## Memory Pointer/Counter Register :R2

The memory register :R2 is an address/length register. The two most significant bits of register 2 serves as an index for:

- WriteBaseAddress
- ReadBaseAddress
- WriteLength
- ReadLength

All other bits serve as pointers/counters for memory read or write actions. Register  $:R2[0,29...0]$ ,  $R2[4,29...0]$ ,  $:R2[8,29...0]$ ,  $:R2[c,29...0]$  can be read at any time with the  $:z$  command. The length registers contain the current count value and can be read with  $:R2[8,29...0]$ ,  $:R2[c,29...0]$ .

Syntax	Bits	Value	Description
$:R2<ixxxxxxx>$ $i = 0, 4, 8, 0xc$ $xxxxxxx = 7$ ASCII hex characters	31...30	0	WriteBaseAddress register [8words]
		4	ReadBaseAddress register [8words]
		8	WriteLength register [8words]
		c	ReadLength register [8words]
	29...0	0x3fffffff...5	Write/Read address/length [8words]

**Memory Read Register :R3[31...30] = 0**

R3 can be used as read control bit and to set the trailer counter.

Syntax	Bits	Value	Description
:R3<xxxxxxxx> xxxxxxxx = 8 ASCII hex characters	0	0	stop Read memory
		1	read frames from memory (address = R24xxxxxxxx, length = :R2Cxxxxxxxx)
	1	0	read single frame range from memory address
		1	read last previously written frame from memory continuously if :R1[1...0] is 3 and :R3[0] = 1. WriteXorRead frames to/from memory continuous if :R1[1...0] is 1
	2	0	reserved
	29...3	0x3ffffff.... 5	write trailer counter
	31...30	0	select trailer counter

bits 1...0 select mode of read operation:

If :R3[1...0] = 1, a single frame range of the length :R2[c,29...0] is read from the memory address :R2[4,29...0]. Bit 0 will be cleared automatically after this action is completed. Use this mode to selectively retrieve an image or a sequence of images from memory, one at a time.

If :R3[1...0] = 3, frames of length = :R2[c,29...0] are read from last previously completely written memory address continuously.

If bit 1 is cleared while reading continuously, the current read action is continued until :R2[c,29...0] will be expired. The reading will be stopped and bit 0 cleared automatically.

If :R3[1...0] = 3 and :R1[1...0] = 1, a special WriteXorRead action is done continuously. After one single frame is written, a single frame is read. This will be repeated until some other mode is selected. WriteXorRead can be used for automatic life display action without issuing memory commands. It maintains the integrity of the read images. Reading is much slower than writing (maximum ¼ of write bandwidth). Otherwise a read image would be overwritten by new images while reading is in progress.

If :R3[1...0] = 3 and :R1[1...0] = 3, memory is written and read at the same time. Maximum read bandwidth is 1/32 of write bandwidth. Use this mode only for test purpose.

If :R3[31...30] = 0, bits 29...3 contain the trailer counter. This counter counts frames (and not the number of Bytes!) to be written after bit 1 of :R1(the continuous write bit) has been reset, e.g. by a sending an according :R1-command or by applying an external trigger. Register 3 can be read at any time with the :z6 command. It will return its content in 8 ASCII characters.

## Concatenated Memory Register Settings

Register :R1 and :R3 bits 1...0 define several modes of memory operation:

:R1[1...0]	:R3[1...0]	Mode	Remark
0	0	memory stop	no memory activity, memory is refreshed
1	0	write single	write frames with a total length of: :R2[8,29...0] to memory pointed to by :R2[0,29...0]
3	0	write continuously	writes frames with a total length of: :R2[4,29...0] to memory pointed to by :R2[0,29...0] continuously use this mode for circular storage stop continuous writing by clearing :R1[1] when :R3[31...2] = 0 if :R3[31...2] is > 0, as many frames are written as defined by the trailer counter after a stop is issued
0	1	Read single	read a single frame range with length: :R2[c,29...0] from memory pointed to by :R2 [4,29...0]. use this command to read memory. set the read length to one or more frames. Length of multiple frames is more efficient, because viewer commands are issued.
3	1	write continuously, read single	use this mode to read data that is being circularly written.
1	3	WriteXorRead	memory is alternatively written and read. use this mode for live display.
3	3	write and read continuously	frame to be read is the last previously and completely written frame. Use this mode for live display while (continuous) recording is in progress size for read frame = :R2[0xC,29...0]

## ExposureTime Register :R3[31...30] = 4

The ExposureTime register loads a 28 bit down counter that is clocked from the internal x-counter counting the sensor clock modulo 86. Its output defines the width of the internal exposure signal that is also output on the strobe output signal.

Range for ExposureTime register: 0x00000002 ... 0x0001ffff

Calculation of ExposureTime:  $t_{exp} = R34 * 86 / \text{sensor clock}$

$$\begin{array}{ll} t_{exp} & \text{exposure time in s} \\ \text{sensor clock} & \text{sensor clock in Hz} \\ R34 & \text{value of R34} \end{array}$$

**Example:**  
*sensor clock = 89.100 MHz*  
*ExposureTime/step = 0.965  $\mu$ s*  
*min. ExposureTime = 1.93  $\mu$ s*  
*max. ExposureTime = 126.51 ms*

**Note:** ExposureTime setting is limited by the time for one frame, which is set with FrameRate register. ExposureTimes, which are longer than one frame, will be reduced to the duration of one frame.

## FrameRate Register :R3[31...30] = 8

The FrameRate register loads a 28-bit down counter that is clocked from the internally fixed 25MHz quartz oscillator. Its output triggers the internal frame rate logic if not set to external synchronization.

Calculation:  $R38 = (f_{osz}/\text{FrameRate}) - 1$  (hex value)

$f_{osz}$  frequency of quartz oscillator = 25,000 MHz

FrameRate frame rate in fps (frames per second)

R38 value of R38

**Example:** 1000 fps wanted

$$R38\text{value} = (25,000 \text{ MHz} / 1000 \text{ Hz}) - 1 = 24.999_{dec} = 0x61A7_{hex}$$

Resulting command for R38: :R3800061A7 (in ASCII characters)

## Read Single Memory Registers

Use :z1 ... :z8 commands to read memory registers :R1...:R38. Eight ASCII characters with their hex contents are returned.

Syntax	Description
:z1	read :R1, bit 0 might be clear thru previous stop write action
:z2	read :R2[0,29...0]
:z3	read :R2[4,29...0]
:z4	read actual write pointer
:z5	read actual read pointer
:z6	read :R30, bit 0 might be clear thru previous stop read action
:z7	read :R34 (not yet supported)
:z8	read :R38

**Note:** Result of command :z4 and :z5 will change with repeated readings if memory read/write is in progress.

## Read All Analog Registers

Use command :Za to read all memory registers :a1-:a8 with one instruction.

Syntax	Description
:Za	read all memory registers

Response 8\*2 characters, e.g.:

5c64e4ead7207b6e

| | | | | | | | |a8

| | | | | | | | |a7

| | | | | | | | |a6

| | | | | | | | |a5

| | | | | | | | |a4

| | | | | | | | |a3

| | | | | | | | |a2

| | | | | | | | |a1

## Sensor Commands

The sensor logic of the CAMMC134x is the same as the logic of the industrial proven CAMMC131x camera series. Therefore all CAMMC1310 commands apply to the CAMMC134x.

Syntax	Range	Response	Description
:a<n><xx>	<n> = 1...8 <xx> = 0...ff <sub>h</sub>	ACK*	set one of eight analog voltages for the sensor
:b<n>	<n> = 0...4	ACK*	select baud rate: 0=9600 Bd (default setting), 1=19.2 kBd, 2=38.4 kBd, 3=56.8 kBd, 4=115.2 kBd
:c	--	--	RESET and initialization of the camera, new load of PowerUpProfile; duration: some seconds
:e....	--	--	receive and save new sensor FPGA configuration
:fc	--	ACK*	load factory profile to camera profile
:gc	--	ACK*	load power-up profile to camera profile
:i<n><c....c>	<n>= 0...f <sub>h</sub> , <c....c> = 16 char	ACK*	write one line of text buffer (16lines x 16 char)
:n...	48 char	ACK*	write camera name into camera
:pc	--	ACK*	save PowerUpProfile to non-volatile memory
:r<n><xxx>	<n> = 1...f <sub>h</sub> , <xxx> =0...3ff <sub>h</sub>	ACK*	write a FPGA - register
:v	--	#005433A 11-B2.03- V0.82- F1.71	read serial number (#), part of identifier, microcontroller-version (V....) and FPGA - version (F....).
:w	--	camera profile:	read actual PowerUpProfile, data output in hex



		80 bytes in hex	
:z<n>	<n> = 1...8	e.g. 03ff4f2c	read memory register values directly from FPGA
:A<n>	<n> = „Y“, „Y“, „n“, „N“		enable or disable a command acknowledge or not acknowledge (ACK or NAK)
:Dc<c><ij>...	<c>=„l“, „l“, „r“, „s“ <ij>=0...ff <sub>h</sub> ...= data (hex)	ACK* for <c>=„r“: data in ASCII or hex	column correction commands for loading or reading a correction table, enabling or disabling function and reading status byte
:ERASE<ccc>	<ccc> = „APP“, „EPCS1“	--	erase of camera internal firmware, camera stops working, please, read command description before executing it
:F<nnnnnn>	<n...n>=different functions and values	ACK*	program sensor clock directly in units of 1 kHz additionally load, read, save the clock setting table to or from non-volatile memory
:l<n>	<n>= 0...f <sub>h</sub>	ACK*	read text line no. <n>, 16 bytes answer
:N	--	ACK*	read camera name, 48 bytes length
:P<nnnnnn>	<n...n>= 0 – 150000 (ASCII)	ACK*	program pixel clock directly in units of 1000Hz, insert leading zeros
:R<n><xxxxxx xx>	<n>=1-3h, <x...x> = hex value	ACK*	write memory register
:T	--	+45.0°C	read camera internal temperature
:V	--	e.g. 13400000 00003831	read complete identifier of the camera
:W	--	Camera profile: 265 bytes in ASCII	read actual PowerUpProfile, data output in ASCII
:?par	-	<xx>	read 8 bits data of port A
:?paw<xx>	<xx> = 0...ff <sub>h</sub>	ACK*	write 8 bits to port A bit 7 = switch to standby mode
:k<n>	<n> 0...1	ACK*	switch to standby mode after end of recording: 0 = no switching 1 = switching if bit 27 of Memory write register :R1 is set

## Sensor Registers

All sensor registers are 10 bits wide and represented by three ASCII hex characters 000...3ff.

Syntax	Bits	Value	Description	
:r1<xxx>	9...0	0...0x3ff	address of first line to be output	
:r2<xxx>	9...0	0...0x3ff	burst trigger in non-circular mode	
			0	no trigger
			1 ... 0x3fe	number of frames per trigger
0x3ff	recording while trigger is active			
:r3<xxx>	9...0	0...0x3ff	number of lines + 1	
:r4<xxx>	9...0	0...0x4f	address of first pixel of a line	
:r5<xxx>	9...0	0...0x4f	address of last pixel of a line	

:r6<xxx>	9...0		modes of operation
	0	0	invert „arm“ signal
	1	0	reserved
	2	0	normal operation
		1	vertical binning
	3	0	reserved
	7...4	0	camera stop
		1	synchronous operation, no shutter
		3	synchronous operation, with shutter
		0xB	asynchronous exposure, shutter control by pulse width
		0xF	asynchronous exposure, shutter control by timer
		8	0
	9	0	reserved
:r7<xxx>	9...0		modes of operation
	0	0	reserved
	1	1->0->1	clear image timer/counter
	3...2	0	digital gain 0, multiply grey values by 1
		1	digital gain 0, multiply grey values by 2
		2	digital gain 0, multiply grey values by 4
		3	digital gain 0, multiply grey values by 8
	4	0	normal operation
		1	enable horizontal pixel binning
	5	0	reserved
6	1	test pattern	
7	1	reserved	
8	1	invert trigger input	
9	1	enable exchange columns	
:r8<xxx>	6...0	0...0x4f	ImageBLITZ window x-start (mod16)
	8...7	0	reserved
	9	1	indicates an element of the exchange columns table
:r9<xxx>	9...0	0...0x4f	ImageBLITZ window x-end (mod16)
:ra<xxx>	7...0	0...0xff	threshold
	8		release condition, msb
	9		enable ImageBLITZ top/bottom line zebra striped indicator in the frames
:rb<xxx>	9...0	0...0x3ff	release condition 10 is :ra[8]
:rc<xxx>	9...0	0...0x3ff	ImageBLITZ top line address
:rd<xxx>	9...0	0...0x3ff	ImageBLITZ bottom line address
:re<xxx>	9...0	0...0x3ff	write ImageInformationField

:rf<xxx>	0	1	enable external sync signal
	1	1	select „arm“ signal on strobe output
	2	0/1	set “arm” signal accordingly
	3	1	invert external Sync Signal
	4	0	reserved
	5	0	reserved
	6	1	enable IRIG-B processing
	7	1	disable trigger input
	8	0	reserved
	9	1	enable bad pixel correction

## Image Quality

There are eight D/A converters which can be used to influence image quality. Black level (VCLAMP3) might be adjusted if sensor clock changes. All eight parameters are stored in a non-volatile memory as part of the selected profile.

Most analog parameters will directly influence the image quality and may differ between each camera. Thus changes should be made very carefully. It is recommended to use the factory preset adjustments.

### VLN1

VLN1 is a sensor internal bias voltage that goes to column analog buffers. The value can be optimized for better column gain uniformity. VLN1 has also an influence to brightness and fixed pattern noise. In order to adjust it set the lens out of focus and to a medium grey level.

Command:                :**a1**<x<sub>1</sub>x<sub>0</sub>>                <x<sub>1</sub>x<sub>0</sub>> : range typ. 32h .... C8h

Response:                none or ACK (if enabled)

### VREF1, Gain

VREF1 sets the maximum unclipped signal conversion voltage. This is the threshold for the A/D converters. The standard value is 66h for approximately 1V. One step is app. 10mV. To increase the gain the value of a2 has to be lowered.

Command:                :**a2**<x<sub>1</sub>x<sub>0</sub>>                <x<sub>1</sub>x<sub>0</sub>> : range, typ. 14h .... 96h

Response:                none or ACK (if enabled)

### VREF2

VREF2 is the ADC calibration voltage and is typically adjusted to 46h. VREF2 influences the column correction stage inside the sensor and should not be set to values below 30h.

Command:                :**a3**<x<sub>1</sub>x<sub>0</sub>>                <x<sub>1</sub>x<sub>0</sub>> : range, typ. 14h .... 96h

Response:                none or ACK (if enabled)

### PIXVDD

PIXVDD is the supply voltage of the analog stage of each pixel inside the sensor. This parameter is important for the image quality. The factory adjustment is recommended to use.

Command:                :**a4**<x<sub>1</sub>x<sub>0</sub>>                <x<sub>1</sub>x<sub>0</sub>> : range, typ. 32h .... 40h

Response:                none or ACK (if enabled)

### VCLAMP3, Black Level

VCLAMP3 or Black Level changes the basic brightness of the image. A higher value will lower the brightness. If VCLAMP3 = 0 and camera lens is closed most of the pixel values are higher than 0. This parameter may change in dependence of the sensor clock. Increase this parameter until the grey value of each pixel in no light condition (closed lens) is close to zero.

Command:                :**a5**< $x_1x_0$ >                < $x_1x_0$ >: range, typ. 00h .... ffh  
Response:                none

**Note:** For color cameras: Changes of VCLAMP3 may also change the white balance of the image.

### VREF3

VREF3 works inverted to VCLAMP3, means a higher value of VCLAMP3 increases the brightness of the image. The factory setting of VREF3 is recommended.

Command:                :**a6**< $x_1x_0$ >                < $x_1x_0$ > : range, typ. 00h .... ffh  
Response:                none or ACK (if enabled)

### VLN2

VLN2 is a sensor internal bias for ADC comparators. The factory presetting is recommended to use. The adjustment of this parameter does not depend on the camera settings.

Command:                :**a7**< $x_1x_0$ >                < $x_1x_0$ > : range, typ. 32h .... 78h  
Response:                none or ACK (if enabled)

### VLP

VLP is a sensor internal reference voltage for the buffers. The factory presetting is recommended to use. It does not depend on the camera settings.

Command:                :**a8**< $x_1x_0$ >                < $x_1x_0$ > : range, typ. 32h .... ffh  
Response:                none or ACK (if enabled)

## Image Size and Position

Image size and position within the sensor is defined by four parameters:

Bit(s)	Description
r1[9...0]	number of first line, 0...3FD <sub>h</sub>
r3[9...0]	number of lines, 0...3FF <sub>h</sub>
r4[6...0]	address/16 of the first pixel
r5[6...0]	address/16 of the last pixel

### Address of the First Line

Register r1 defines the first line to be displayed.

Command:                :**r1**< $x_2x_1x_0$ >                < $x_2x_1x_0$ > .... Range 000h ....3fdh  
Response:                none  
Example:                 :r1100  
                              100h = image starts at line 257

**Number of Lines**

Register r3 defines the number of lines to output.

Command:     **:r3**<x<sub>2</sub>x<sub>1</sub>x<sub>0</sub>>                    <x<sub>2</sub>x<sub>1</sub>x<sub>0</sub>> .... Range 000 h ...3ffh

Response:     none

Example:     :r3200                    200h = display 513 lines

**Note:** The sum of r1 and r3 must be  $\leq 0x3ff/1023$ .

**Address of the First Pixel of a Line**

Register r4 defines the leftmost pixel. The value is the pixel address divided by 16.

Command:     **:r4**<x<sub>2</sub>x<sub>1</sub>x<sub>0</sub>>                    <x<sub>2</sub>x<sub>1</sub>x<sub>0</sub>> .... Range 000h ...4fh

Response:     none

Calculation of the value of r4:

$$\text{Value of r4} = \text{Pixel no.}/16$$

**Address of the Last Pixel of a Line**

Register r4 defines the rightmost pixel. The value is the pixel address divided by ten.

Command:     **:r5**<x<sub>2</sub>x<sub>1</sub>x<sub>0</sub>>                    <x<sub>2</sub>x<sub>1</sub>x<sub>0</sub>> .... Range 000h ...04fh

Response:     none

Calculation of the value of r5:

$$\text{Value of r5} = \text{Pixel no.}/16$$

**Note:** The difference r5 - r4 has to be in the range of  $0 \leq r5-r4 \leq 4fh$ .

## Clock Selection

The MC134x works with two clocks (pixel and sensor clock) inside. Pixel clock is factory preset to 100 MHz, sensor clock to 88 MHz. Both parameters are fixed and should be not adjusted.

Calculation of sensor clock:  $F_{SENS} = 85 \cdot FR \cdot (NUMLIN + 1)$

FSENS	sensor clock in Hz
FR	frame rate in 1/s (=Hz)
NUMLIN	actual number of lines

The calculated sensor clock is selected with the :F command in 1000 Hz units.

**Example:** *87,040 MHz is programmed as :F087040  
The calculated sensor clock is selected with the :F command in 1000 Hz units.*

To set the sensor clock in the following code must be sent to the camera:

Command     :F <x<sub>0</sub>>  
  
                  <x<sub>0</sub>> ... always 6 characters, requested frequency in 1 kHz units  
                  with leading zeros if necessary.

**Note:** For speed and/or the image format changes please use the recommended command sequence in chapter Image Format/Speed change.

## Image Format Change

There are several steps necessary for a change of image format:

1. If the memory controller is not idle (e.g. live image or recording is in progress), program :R3/R1[1...0]==0 and wait for 1/fps (100 ms max for 10 fps) until the last pending image has been output completely.
2. Set memory controller to new linelen/numlin (:R1 ) and number of 16words (:R2[8Cxxxxxx])  
.
3. Set GigE interface to new linelen/numlin parameters
4. Disable sensor controller with :r6[4] = 0
5. Set sensor controller to new image size (:r1,:r2, :r3, :r4, :r5)
6. Enable sensor controller (:r6[4]=1) and wait for 1/fps to insure that there are output correct images
7. Enable (if necessary) the memory controller to desired action.

## Image Speed

A slower Image speed can be requested regardless of the cameras operating mode. (e.g.:idle, life, recording) Do not change the pixel clock, e.g.: do not send the pixel clock code (:Pxxxxx), even if it is the same as it was before.

bits 27...0 of register R38xxxxxx define image speed:

$$F_{\text{frame}} = 25 \cdot 10^6 / (R38xxxxxx + 1) \text{ [Hz]}$$

xxxxxx ....frame speed divider

**Note:** Image speed < (:r3+1) • SensorClock / 85

## Exposure Time

bits 27...0 of register R34xxxxxx define exposure time:

$$\text{ExpTime} = ( 1/F_{\text{sens}} \cdot 85 / R34xxxxxx \text{ [sec]}$$

xxxxxx ....ExpTime multiplier

**Note:** ExpTime < 1/ ImageSpeed

## Synchronization

CAMMC134x cameras are synchronized by an internal or external signal. The internal signal is divided from the 25MHz master crystal clock. Use :R3[31...0] = 8 to program the required divider.

Multiple CAMMC134x cameras can be synchronized to an external signal with a frequency that is below the free-running frame rate of the cameras. A master camera's strobe output can be used to synchronize the slave cameras. Make sure that the master camera's free-running frame rate is selected to be a little below the one of the slave cameras.

Use Pin 8 of the I/O connector as input. Synchronization is enabled with register :rf[0] = 1. Use only with synchronous exposure (:r6[7...4]=3).

## ImageBLITZ Trigger

This signal is generated in the sensor FPGA and fed through the micro controller to the memory control FPGA to stop a cyclic recording action just as the external trigger switch/signal.

When activated, the grey values of an ROI:

**:r8[9...0]** = x-start(mod16),  
**:r9[9...0]** = x-end(mod16),  
**:rc[9...0]** = top line address,  
**:rd[9...0]** = bottom line address

within the visible image area are stored as reference, every time the ImageBLITZ trigger is activated:

**:r7[0]** = 0->1

**Note:** The total number of pixels within the trigger window should not exceed 20480 pixels.

After activation of ImageBLITZ, all subsequent images within the given ROI are compared to the stored image, and if at least once within a group of 10 pixels the absolute value of the difference between actual grey value and stored grey value exceeds the limit given in:

**:ra[7...0]** = threshold

the release condition counter is incremented. If the counter value equals the value given in:

**:rb[9...0]** = release condition [9...0]

**:ra[8]** = release condition 10

the ImageBLITZ output signal is activated and stored until the next activation of ImageBLITZ:

**:r7[0]** = 0->1 happens.

The trigger ROI is marked by a top & bottom dashed line when activated.

## Digital Gain

Out of the 10-bits sensor data either the most significant 8 bits (gain 1), or bits 8...1 (gain 2), or the least significant 8 bits (gain 4) are selected.

Command: **:r700x**

x = 0: gain 1

x = 4: gain 2

x = 8: gain 4



## Test Image

For testing of camera logic and video data transmission, sensor data can be replaced by an internal gray scale pattern with pixel values of 0...127. Use digital gain command to see pixel values of 0...255.

Command example: **:r7040 r7[6]**

Response: none

## Profile Processing

All camera settings are loaded or stored as complete data blocks (= Profiles). There are 3 profiles, the Camera profile, the PowerUpProfile and the factory profile

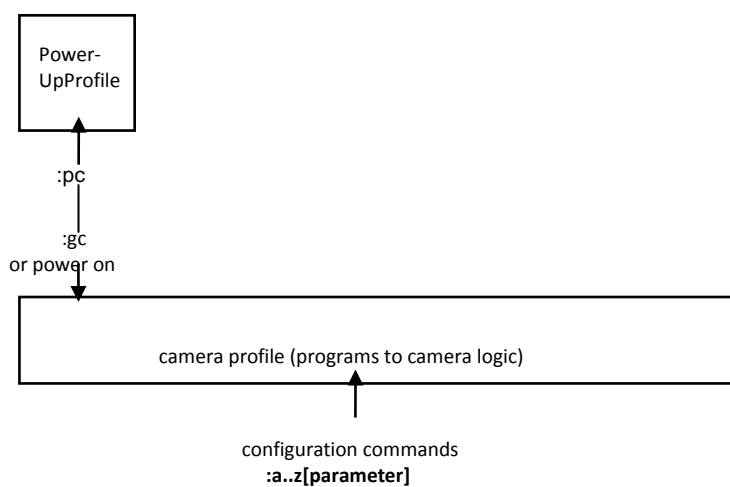

## Read Camera Profile

The response to the read Camera profile command **:w** is a hex string of the contents of all actual camera registers. See chapter 0 Read Camera Settings

## Write PowerUpProfile

The volatile camera profile can be stored to the non-volatile PowerUpProfile, which is used as camera setting and adjustment during start-up of the camera.

Command: **:pc**

**Note:** Issue this command only, if the PowerUpProfile was successfully tested.

## Load Camera PowerUpProfile

Loads the PowerUpProfile to the camera profile and adjusts all camera settings according to the settings in the PowerUpProfile.

Command: **:gc**

### Load Factory Profile

The camera has an internally stored factory profile, which can only be read, but not changed. With command `:fc` the profile can be loaded into the camera profile and may be used. It's preset to 1.280 x 1.024, 1.000 fps.

Command: `:fc`

### Read Serial Number, Firmware Revision and Model

The serial number, firmware revision, and camera identification can be read with the `:v` command.

Command: `:v`

Response(e.g.): `#312340033-B2.03-V1.01-F1.85␣`

The response string is `#312340033-B2.03-V1.01-F1.85␣`. The components are:

- Serial number: `312340033`
- Firmware versions: `B2.03-V1.01`
- Camera identifier: `F1.85`
- CR+LF (carriage return and line feed): `␣`

Firmware versions e.g.:

B2.03	....	bootloader program version of microcontroller
V1.01	....	application program version of microcontroller
F1.85	....	sensor FPGA program version

Identifier bit no.	Bit mask in hex	Description	Values
0	0001	camera type (mono, color)	0 = monochrome 1 = color
2,1	0006	no. of memory modules - 1	0 = 1 memory module 1 = 2 memory modules
3	0008	reserved	0
4	0010	output interface	0 = not defined 1 = gigabit Ethernet
5	0020	size per memory module	0 = 2 GByte 1 = not defined
6	0040	frame size limitation and/or speed limitation	0 = none 1 = limited
7	0080	reserved	0
8	0100	achievement	0 = HG (high G) 1 = standard
9	0200	company version	0 = Weinberger 1 = Mikrotron
11,10	0C00	camera type	00 = MC133x 01 = MC253x 10 = MC134x 11 = not defined
12	1000	multi-sequence feature (MS)	0 = disabled 1 = enabled
13	2000	ImageBlitz feature (IB)	0 = disabled 1 = enabled
14	4000	IRIG-B	0 = IRIG-B not supported 1 = IRIG-B is supported
15	8000	reserved	0

**Example:** version string: #012343813-B2.03 ...  
identifier = 3813 means:

- color camera
- Gigabit Ethernet interface
- 2 memory modules with 2 GByte = 4 GByte memory
- no limitations
- standard version
- for Mikrotron
- camera type = MC134x
- Multi-sequence and ImageBlitz enabled

## Read Extended Camera Identifier

Command: `:V`

Response(e.g.): `1340000000003B30` ↵

Extended Camera Identifier (ECI)      ↗

Base Camera identifier (BCI)      ↖

CR+LF  
(carriage return + line feed)

**Example:** *Extended + Base Camera Identifier 103B30 means*

- *monochrome camera*
- *2 GByte memory*
- *standard (not HI-G) Mikrotron MotionBLITZ Cube4 (CAMMC134x)*
- *Multi sequence and ImageBlitz installed*
- *Memory made of 1Gbyte Rams*

Extended + Base Camera Identifier description, all digits in hexadecimal notation: 8+2+1 = B

Char number in ECI	16	15	14	13	7	6	5	4	3	2	1
<b>MotionBLITZ CAMMC134x, 1,6s memory, monochrome</b>	1	3	4	0		0	0	0	b	3	0
<b>Color</b>											+1
<b>HI-G</b>									-1		
<b>3s/6s memory, 4/8 GByte total</b>											+2/+4
<b>Standby</b>						+1					
<b>Multi-sequence</b>								+1			
<b>ImageBLITZ</b>								+2			
<b>RAM Chip: 1Gb</b>							+0				
<b>RAM Chip: 2Gb</b>							+2				
<b>RAM Chip: 2Gb Dual Die</b>							+3				

## Read Camera Settings

The actual camera settings can be read out. The result will be the values of all camera registers.

Command:                    :**w**                    Output as hexadecimal digits  
(Format: 80 bytes total binary string)

Response (e.g.):

```
5C 64 E4 EA D7 20 7B 6E 10 00 00 08 77 20 00 00 00 00 01 FF 00 00 00 1F 00
31 00 87 00 10 00 10 00 01 00 00 00 00 00 03 00 00 02 A 01 FF 1F 2C 00 00 00
00 40 00 00 00 80 00 40 00 C0 00 40 00 00 00 00 04 40 00 00 81 80 00 13 87
C0 00 00 00
```

all values hex, e.g.: 5C<sub>HEX</sub> = 92<sub>DEC</sub>

Sequence of transmitted data bytes:

A1 A2 A3 A4 A5 A6 A7 A8 Sa Sb r1 .... r15 R1 R20 R24 R28 R2C R30 R34 R38 R3C

A1....A8	8 * 1 byte image level control (FPN, contrast...)
Sa	3 Bytes pixel clock in kHz, e.g. 10 00 00, i.e. 100 MHz
Sb	3 Bytes sensor clock in kHz, e.g. 08 77 20, i.e. 87,7 2MHz
r1...r15	15 * 2 bytes(high byte first) image control, (image position, size, sync....)
R1...R38	7 * 4 bytes (high byte first) memory registers, exposure time & image speed
R3C	1 * 4 bytes (high byte first) reserved register
<b>:w</b>	Output the camera settings as ASCII string Format: 8 * (1 * CR + 32 ASCII-chars) plus 1 * CR at the end, i.e. 265 Bytes in total

## Image Information Field

Every image is marked with 32 Bytes that replace the first 32 Pixels of every image.

Bytes	Value	Description
3...0	0xFF00FF00	start of image marker
5...4	0...0xFFFF	image counter
7...6	0...0x3FF	image row start address
7, bits 7...4	0...0xF0	digital input 4...1
14...8	0...0xFFFFFFFF	absolute timer, counts every 51,52 usec, clear when ImageInformation field is deactivated
15	0...0xFF	analog Input
27...16	ASCII string	first line of free text
31...28		IRIG-B

Bytes 27...16 are automatically updated when the first line of Free Text (next chapter) is written.

The image counter and the absolute timer is cleared when this function is deactivated/activated. (toggle r7[1])

Command example: **:r7002** r7[1]

Response: none

## Memory Information Field

The special “end of recording frame” contains the memory information field. This quasi special image (memory space 0x14000 ... 0x27fff) is marked with 76 Bytes that replace Pixel 32 to 109 of that image. Every four Pixel contain a DWORD with the following description:

DWORDS	Bits	Description
15...0	28...0	value of write pointer after completion of one of up to 16 sequences.
	31	wrap flag within one of 16 rings
16	31...0	register :R1 when recording was started
17	31...0	register :R2[8] when recording was started
18	31...0	register :R3 when recording was started

This information is needed for getting the chronological order of a recorded sequence. The “end of recording frame” is for internal use only. The area for the recorded sequences begins immediately after this frame.

Cameras with firmware versions before MC134xM638F259.ibf hold the memory information field in the live-frame area (memory space 0 ... 0x13fff), the area for the recorded sequences begins at address 0x14000.

## Free Text

Up to 16 lines, 16 characters of free text are stored as long as the MC134x is powered. Use this command to store descriptive text and absolute time together with recorded sequences.

Command: **:i<n><16char.text>** ; write free text  
n = text line number

Command: **:l<n>** ; read free text  
n = text line number

## IRIG-B

MC134x equipped with an IRIG-B input can decode the modulated 1 kHz time code that is typically derived from a GPS receiver. The MC134x internal frame rate time base is then synchronized once per second to the IRIG-B 1sec marker, and therefore phase aligned to the 1 kHz IRIG-B signal. The decoded time code is inserted in Image Information Field into each image according to the following format:

Byte	28	29	30	31	32
Bits	7654 321	7654 321	7654 321	7654 321	7654 321
Time BCD	100d ----	10d 1d	10h 1h	10m 1m	10s 1s

1s.: 1's seconds of the minute in BCD Code

100d.: 100's days of the year in BCD Code

10d.: 10's days of the year in BCD Code

1d.: 1's days of the year in BCD Code

10h.: 10's hours of the day in BCD Code

1h.: 1's hours of the day in BCD Code

10m.: 10's minutes of the hour in BCD Code

1m.: 1's minutes of the hour in BCD Code

10s.: 10's seconds of the minute in BCD Code

The decoded Time is GMT.

## Standby Mode

The intended purpose of the standby mode is to store the camera's recorded images for a longer time (up to ca. 20 hours) without any external power supply.

To manage this, in standby mode several components of the camera's electronic will be shut down and mainly only the image memory will be provided with power.

In standby mode, there is no access to the camera's image memory.

There are two different techniques to set the camera into standby mode:

### Switch to Standby Immediately

To get the camera into the standby mode immediately you have to

1. Press the camera's power switch for a short moment (less than 1 second), when the camera is ready-to-operate or
2. Set bit 7 of the camera's port A  
This is achieved by reading the actual content of the port A with the command "?:par", setting the bit 7 in the read string and resending this to the camera with the "?:paw" command.

### Switch to Standby After the End of a Recording Sequence

In order to switch to standby mode automatically after the end of a recording sequence, two conditions must be met:

1. bit 27 of Register :R1 must be set to 1
2. the enable standby after end of recording command “:k1” must be sent to the camera before the sequence is finished

### Switch from Standby Mode to Normal Operation

To get the camera out of the standby mode you have to press the camera’s power switch for a short moment (less than 1 second).

**Note:** Please pay attention: If you press the switch longer than 1 second, you will shut down the camera completely and the camera’s recording will be lost!

### Standby Mode Indication by LEDs

The standby mode will be indicated by the LEDs in the following manner:

- the lower LED (TRIGGER) is switched off
- the upper LED (POWER) is flashing:

Power LED color	Power supply	Remark
red / orange constant flashing	external	
green flashing 1 ... 5 times every 2 seconds	internal (battery)	If the battery is fully charged, there is a quintuple blinking. If the battery gets empty, there is a single blinking.



## Firmware

### Update Firmware

CAMMC134x's logic is integrated into two FPGAs (**F**ield **P**rogrammable **G**ate **A**rray), which's configuration is stored in an EEPROM. Upon power up or a command the FPGA is loaded with this configuration. Configuration data can be downloaded via the Gigabit Ethernet interface. Mikrotron may provide configuration files (\*.ibf) on request.

After downloading configuration data, this data will be permanently stored in the EEPROM, and the FPGA will be configured with the new data. Besides a power cycle, the `:c` command can be used to reconfigure the FPGA with the internally stored configuration data.

**Note:** Download of \*.ibf file via serial link with 19,200 Bd takes app. 1.5 min. There should be no loss of power or communication during this time!

### Reset and Configuration of the Internal FPGA

The command `:c` executes a reset in the camera. The FPGA will be reconfigured and all internal registers reloaded with the last saved PowerUpProfile. The FPGA is also configured after each power up.

Command: `:c`

Response: none

## Assigning an IP Address

Your PC communicates with the camera via Ethernet. Therefore an appropriate IP address has to be assigned to the network card.

Normally, the IP address will be assigned automatically after connecting a camera. This may take a few minutes. In case you want to accelerate this process or you want to assign a certain IP address, proceed as described below.

**Remark:** You need administrator rights to do this!

### Procedure:

1. **Connect your camera via Gbit Ethernet with your PC (☞ page 11)**  
Use the shielded Gbit Ethernet cable.
2. **Open »Network and Sharing Center« in the Windows Control Panel and open your LAN connection**

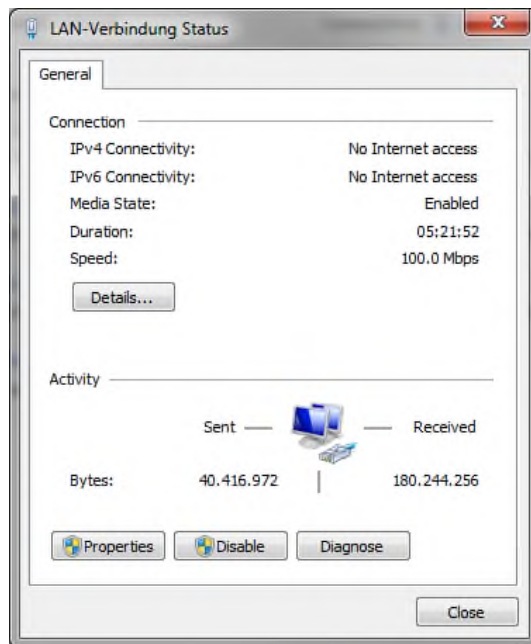

3. **Click [Properties]**  
The properties dialog for the connection will be displayed.

#### 4. Highlight Internet Protocol Version 4 (TCP/IPv4)

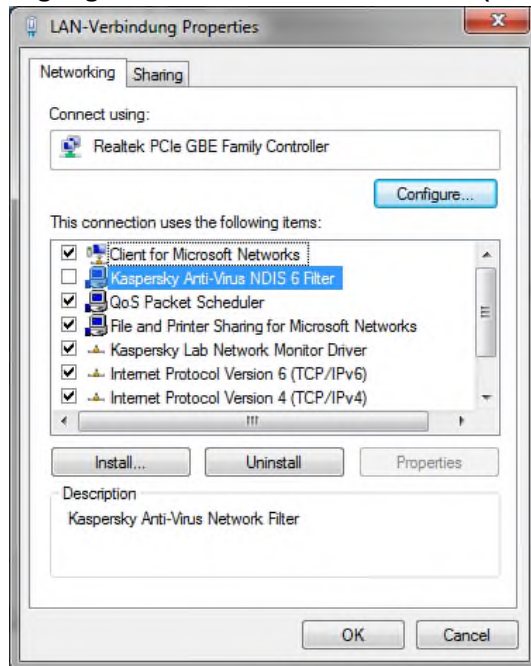

#### 5. Click [Configure]



#### 6. Assign a valid IP address that is currently not in use, e.g. IP:192.168.110.1, Subnet-mask: 255.255.255.0

#### 7. Click [OK]

## Working with Several Network Cards

When working with several network cards, it will be necessary to assign an IP address to each.

If for example the IP address 192.168.77.22 is assigned to the first network card the IP address of the second card will have to differ in at least one address part above the field 255 in the subnet mask.

In the example below the subnet mask contains the number 255 three times. The IP address of the second card has either to differ in the first or the second three digits, for example: 192.169.77.22

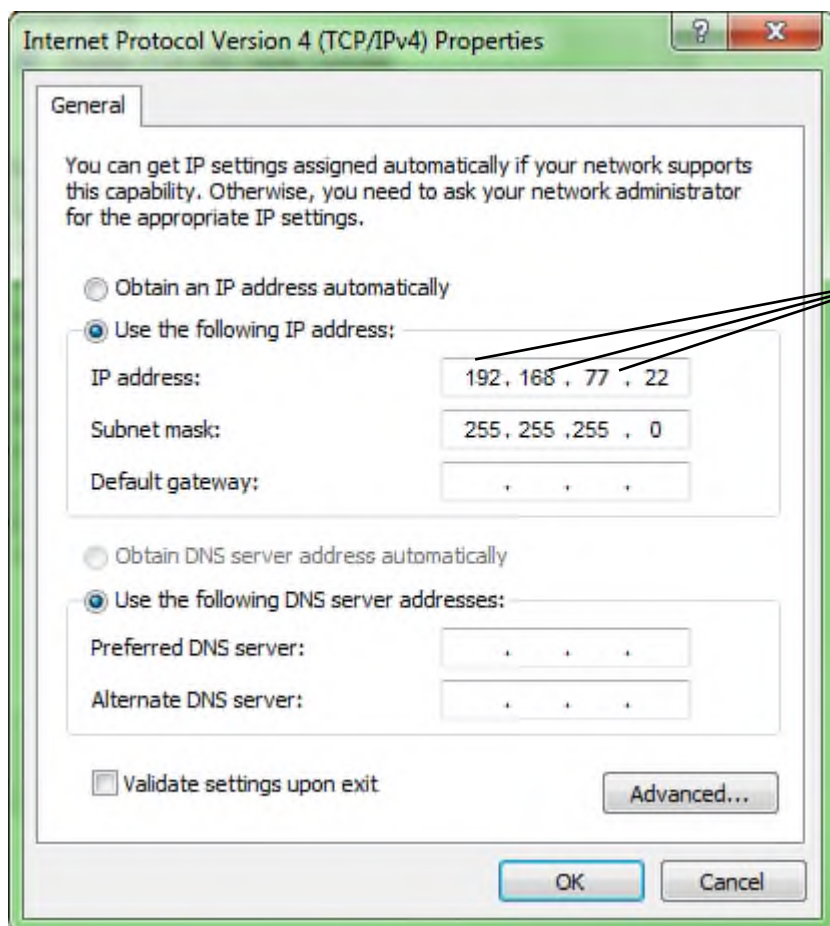

At least one of these address parts has to differ from the IP address of the next network card

Proceed for each card as described on page 17 and make sure that the subnet mask for each card is the same.

## Mount an F-Mount Adapter

---

For fine adjustment of the focal length the c-mount lens adapter with an adjustment range of  $\pm 1$  mm is provided. Use the three screws nearby the sensor window to fasten the lens adapter after a proper adjustment together with the chosen lens.

In case the c-mount adapter has to be replaced by an f-mount lens adapter, proceed as follows:

### 1. Loose the 4 torx screws at the camera front housing

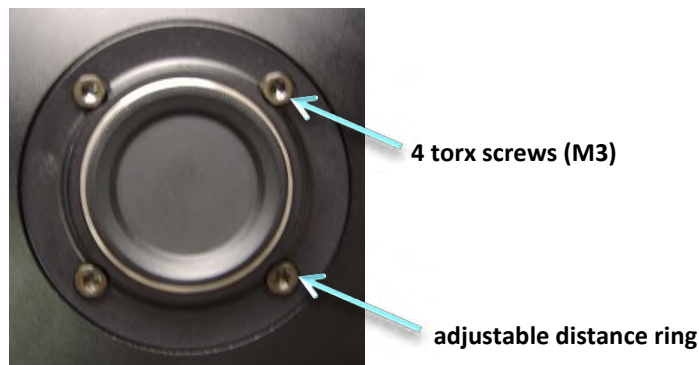

**Remark:** Please, take care that neither the IR-filter of a color camera nor the plating of the inner f-mount cylinder will be damaged.

## Maintenance

---

### Cleaning the Lens

The optical path of the camera needs cleaning occasionally. Information about cleaning the lens is provided by the respective manufacturer.

### Cleaning the IR-filter

MotionBLITZ color cameras contain a filter to suppress infrared (IR) light. Infrared light is part of the visible light spectrum and warps the color of the camera's images. Therefore it is necessary to eliminate infrared light.

Dust and dirt, which may deposit on this filter is best removed by means of an oil free air pressure spray or with a lens cleaning tissue. Sticky mud and fingerprints may be cleared with medical alcohol.



#### **WARNING**

##### **IR Filter Damage**

**Improper cleaning agents may damage the filter. Such damage may alter the quality of the images.**

### Changing the Battery

Cube cameras are equipped with four NiMh accumulator cells which will have to be changed, if the camera does not power-up properly.



#### **WARNING**

##### **Serious Camera Damage**

**The battery of CAMMC134x cameras is equipped with an additional fuse and a temperature probe. Therefore, never change the battery yourself! Instead, contact our service team and ask for a RMA number ([info@mikrotron.de](mailto:info@mikrotron.de)) and send the CAMMC134x camera back to MIKROTRON**

## Technical Data

---

Feature	Value
Camera types	monochrome or color with Bayer Filter
Resolution (number of pixels)	1280 x 1024
Pixel size	12 x 12 $\mu\text{m}^2$
Active area	15,36 (H) x 12,29 (V) mm
Fill factor	40%
Sensitivity at 550nm@Vref = 1V (a2 = 66h)	1.6V/lux-sec@55nm
Spectral response	400 ... 800nm
Shutter	Electronic „Freeze Frame“ Shutter
Trigger	Trigger and Sync input
Internal Dynamic	59 dB
Power supply	10.5 ... 30 V
Power consumption max., continuous recording @ 1.3 GBytes/sec Thermal resistance typ.	15 W 6.25°/W
Serial data link	Gbit Ethernet, baud rate 19,200 Bd
Digital video CAMMC134x	Gbit Ethernet
Shock & vibration	100g, 10grms
Dimensions (WxHxD)	93 x 69 x 92 mm (c-mount) 93 x 69 x 128 mm (f-mount)
Case temperature	+5 ... +45° C
Weight	ca. 900 g
Lens mount	C-mount or F-mount

## Pin Assignments

### Power Connector

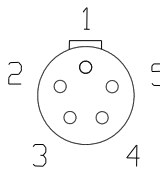
<b>Pinning of matching power plug (male, solder side)</b> 		Select the plug according to your needs (right-angled plug / water resistant etc.) under <a href="http://www.lemosa.com/">http://www.lemosa.com/</a> e.g. straight plug: FGG.1B.305.CLAD42ZN (socket of the camera: EEG.1B.305.CLL)
Pin Nr.	Signal Level	Description
1	Power	+10.5 to 24V
2	Power	+10.5 to 24V
3	n.c.	
4	Power	GND
5	Power	GND

### Trigger Connector

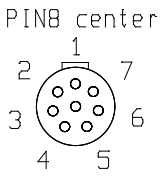
<b>Pinning of matching signal plug (male, solder side)</b> PINB center 		Select the plug according to your requirements (right angle plug / water resistant etc.) under <a href="http://www.lemosa.com/">http://www.lemosa.com/</a> e.g. straight plug FGG.1B.308.CLAD52ZJ (socket of the camera: EEG.1B.308.CLL)
Pin Nr.	Signal Level	Description
1	GND	Opto GND
2	0...2.5V@ 1MΩ	Analog input voltage, 8-bit resolution
3	LVTTL	Sync Output / ARM
4	LVTTL	Digital Input 1
5	LVTTL	Digital Input 2
6	LVTTL	Digital Input 3/ IRIG-B Input *)
7	LVTTL	Digital Input 4/ Trigger Input
8	LVTTL	SYNC Input

\*) **IRIG-B input:** The level of the IRIG-B signal connected at pin no. 6 should be typically 3V for ‚mark‘, 1V for ‚space‘. Important is the ratio of the signal level of mark and space of 3 to 1.



## Spectral Response of CAMMC134x

<b>Sensor type</b>	CMOS, monochrome or RGB (Bayer Filter)
<b>Resolution</b>	1280 x 1024 pixel
<b>Pixel depth</b>	8 bit
<b>Pixel size</b>	12 x 12 $\mu\text{m}^2$
<b>Active area</b>	15.36 (H) x 12.29 (V) $\text{mm}^2$
<b>Fill factor</b>	40 %
<b>Light sensitivity</b>	1.6 V/lux-sec @ 550 nm
<b>Dynamic range</b>	up to 59 dB with multiple slope
<b>Full well charge</b>	63000e <sup>-</sup>

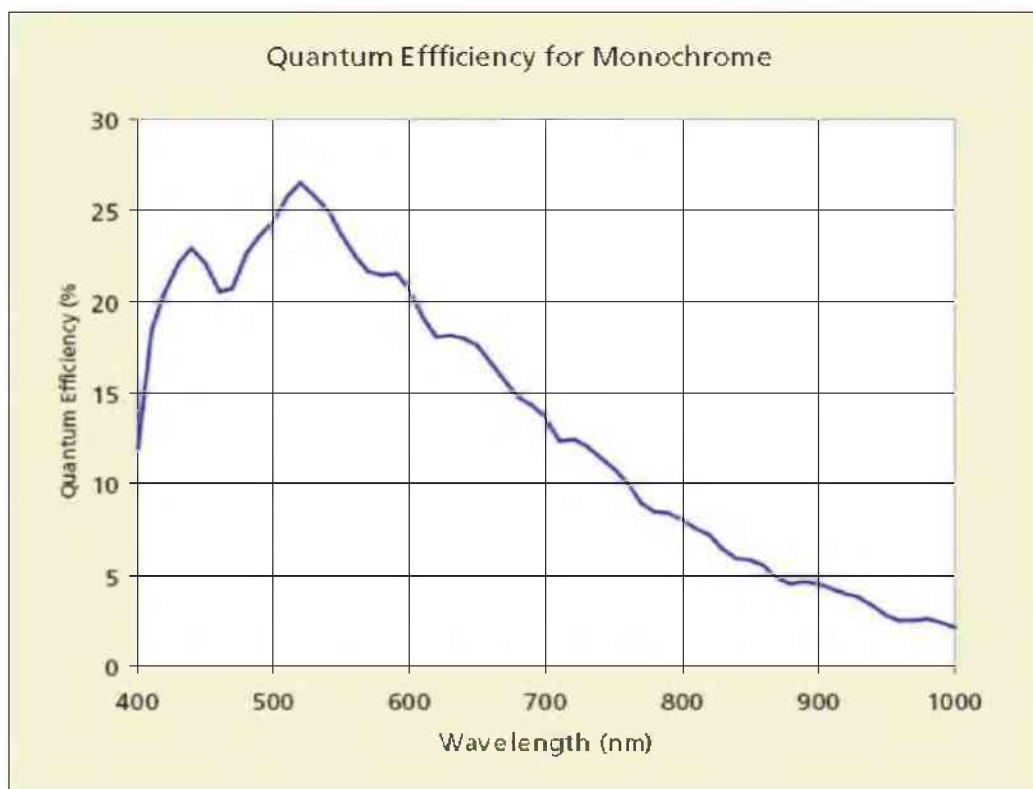

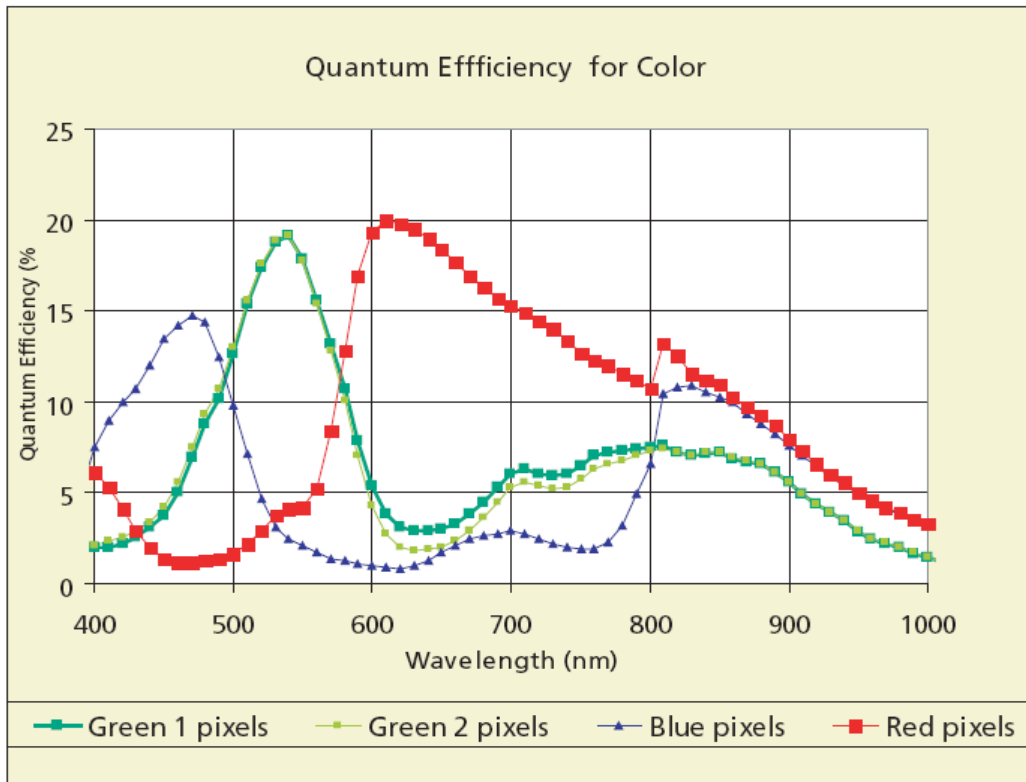

## Dimensions

The camera measures 93 x 69 x 92 mm<sup>3</sup> including the C-Mount but without lens. To fasten the camera there are two mounting holes M 4x7 mm and one tripod connection on each side available.

**Remark:** Maximum torque for M4 fastening screws: 2.5 Nm

### C-Mount

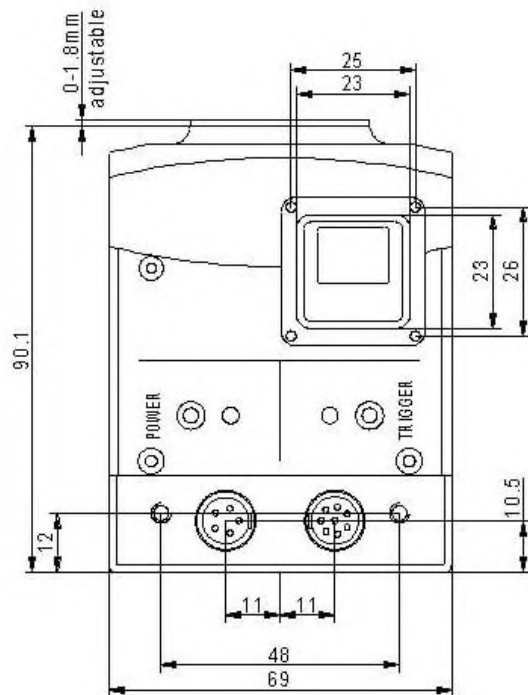

### F-Mount

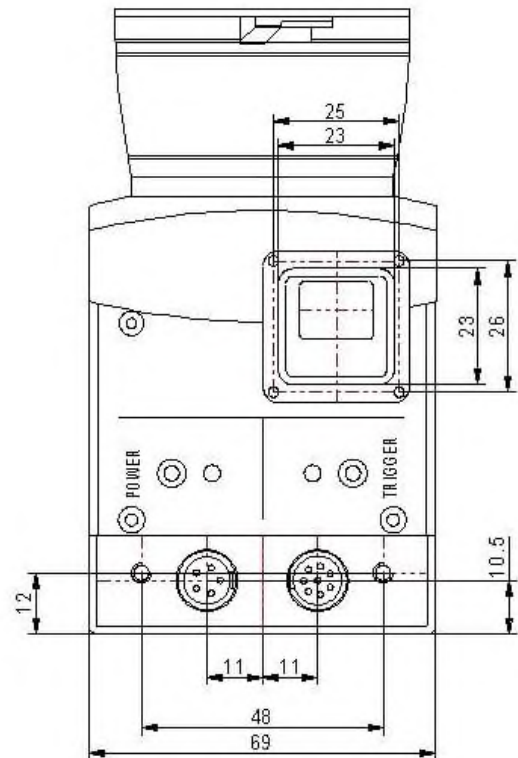

## Cube4 – CAMMC134x Camera

## Dimensions

## C-Mount

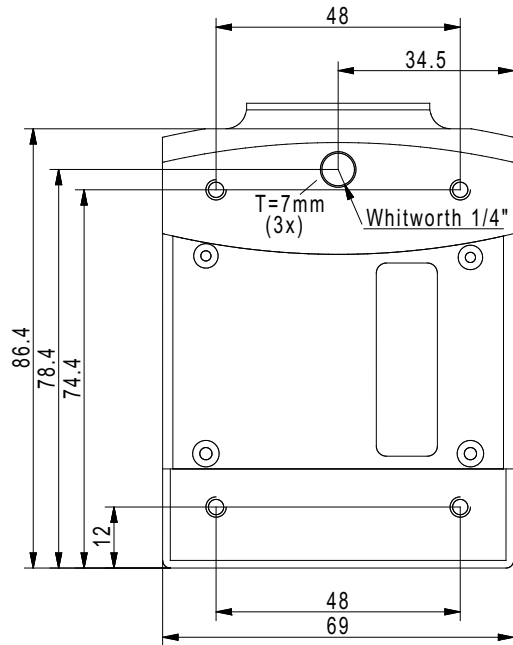

## F-Mount

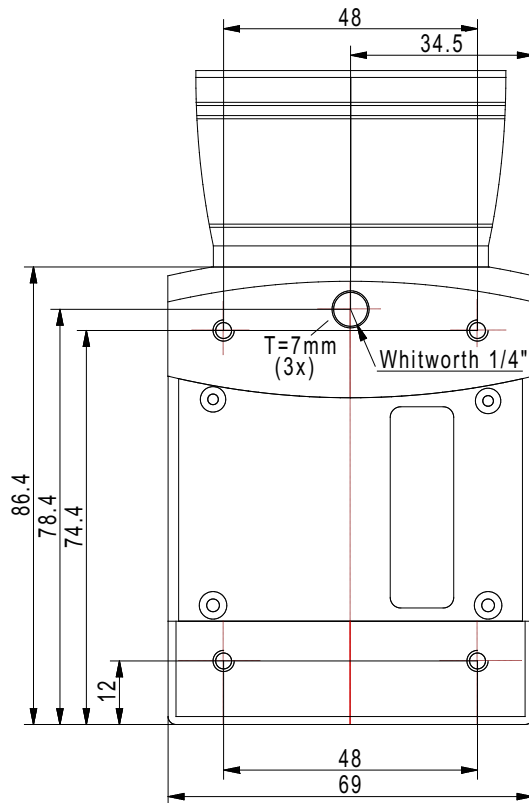

## **CAMMC134x – Reference Guide**

**Copyright © 2018 Mikrotron GmbH**

**This version has been produced on 26<sup>th</sup> of October 2018 by**



MIKROTRON GmbH  
Landshuter Str. 20-22  
85716 Unterschleissheim / Germany  
Phone: 0049 (0)89 7263420  
[www.mikrotron.de](http://www.mikrotron.de)  
[info@mikrotron.de](mailto:info@mikrotron.de)

31-Mar-16  
SPSV0141A2Fixed Focal Length Lens with Fno 0.85

Model	VS-25085/M42
Focal Length (f)	25 mm
Maximum Aperture Ratio	1: 0.85
Aperture	F 0.85 ~ 16
Angle of View (4/3")	30.3° × 40.0° (Diagonal: 49.1°)
M.O.D	170 mm
TV Distortion (4/3")	-1.21 %
Operation	Manual (Lock screw M2)
Wavelength	Visible
Mount	M 42 P= 1.0
Flange Back	19.53 mm
Sensor Size (max.)	4/3"
Filter Thread	M 55 P= 0.75
Weight (approx.)	570 g
Dimension	$\phi$ 65 (max.) × L = 83.5 mm

※Maximum Aperture Ratio is 1:0.90 with C-Mount Customized

*VS Technology Corporation*



## FTIR engine

C15511-01

### Compact FT-NIR spectroscopic module that can be incorporated into portable analytical instruments

The C15511-01 Fourier transform infrared spectrometer (FTIR) engine is compact enough to carry in just one hand. A Michelson optical interferometer and control circuit are built into a palm-sized enclosure. Spectrum and absorbance can be measured by connecting a PC via USB. It can be applied to real-time measurement performed on site without bringing the measurement sample into the analysis room as well as continuous monitoring.

The optical interferometer has a built-in light input section, beam splitter, fixed mirror, movable mirror ( $\phi 3$  mm), and photodetector. The photodetector acquires light intensity signals that vary depending on the position of the movable mirror. The optical spectrum is obtained by processing (Fourier transform) these light intensity signals.

The FTIR engine has a built-in semiconductor laser (VCSEL: vertical cavity surface emitting laser) for monitoring the movable mirror position, which allows spectrum measurement with high wavelength accuracy.

The product includes evaluation software with functions for setting measurement conditions, acquiring and saving data, drawing graphs, and so on. Furthermore, the dynamic link library (DLL) function specifications are disclosed, so users can create their original measurement software programs.

#### Features

- Compact: palm size
- Optical fiber input type
- High S/N  
Suitable for diffuse reflection measurements and absorbance measurements
- Spectral response range: 1100 to 2500 nm

#### Applications

- Process analysis
- Material inspection
- Farm product inspection
- Plastic screening
- Concrete strength measurement
- Film thickness measurement
- Medical and healthcare equipment

#### Structure

Parameter	Specification	Unit
Optical interferometer	Michelson interferometer (with a built-in $\phi 3$ mm movable mirror)	-
Photodetector	InGaAs PIN photodiode	-
Light input method	Optical fiber input type*1 (with SMA connector)	-
Interface	USB 2.0	-
Dimensional outline*2	49 × 57 × 76 (excluding protrusions)	mm
Weight	Approx. 300	g

\*1: Optical fiber A16963-01 (core diameter: 600  $\mu$ m, NA: 0.22)

\*2: Excluding protrusions of optical input parts and the like

**FTIR engine****C15511-01****▣ Absolute maximum ratings**

Parameter	Symbol	Condition	Value	Unit
Operating temperature	T <sub>opr</sub>	No dew condensation*3	+5 to +50	°C
Storage temperature	T <sub>stg</sub>	No dew condensation*3	-20 to +70	°C

\*3: When there is a temperature difference between a product and the surrounding area in high humidity environment, dew condensation may occur on the product. Dew condensation on the product may cause deterioration in characteristics and reliability.

Note: Exceeding the absolute maximum ratings even momentarily may cause a drop in product quality. Always be sure to use the product within the absolute maximum ratings.

**▣ Optical characteristics [Ta=25 °C, light input through optical fiber (core diameter 600 μm, NA 0.22)]**

Parameter	Symbol	Condition	Min.	Typ.	Max.	Unit
Spectral response range	$\lambda$		-	1100 to 2500	-	nm
Spectral resolution (FWHM)**4	-	$\lambda=1533$ nm	-	5.7	8	nm
Wavelength reproducibility*5	$\lambda_r$	$\lambda=1533$ nm	-	-	0.5	nm
Wavelength temperature dependence	$\lambda T_d$		-0.06	-	+0.06	nm/°C
Signal-to-noise ratio*6 *7	S/N		10000	-	-	-

\*4: Wavenumber resolution (FWHM) equivalent to 25 cm<sup>-1</sup>

\*5: Variation (3 $\sigma$ ) of spectral peak values when  $\lambda=1533$  nm laser light is measured 50 times in succession

\*6: Ratio of the peak value of the spectrum data when light is incident to the root mean square (rms) of noise in the dark state

\*7: Incident light level 40000 counts p.p min., integration count 512, gain setting 1 to 4

**▣ Electrical characteristics**

Parameter	Min.	Typ.	Max.	Unit
A/D conversion	-	16	-	bit
Drive frequency	225	275	325	Hz
USB bus power current consumption	-	450	500	mA

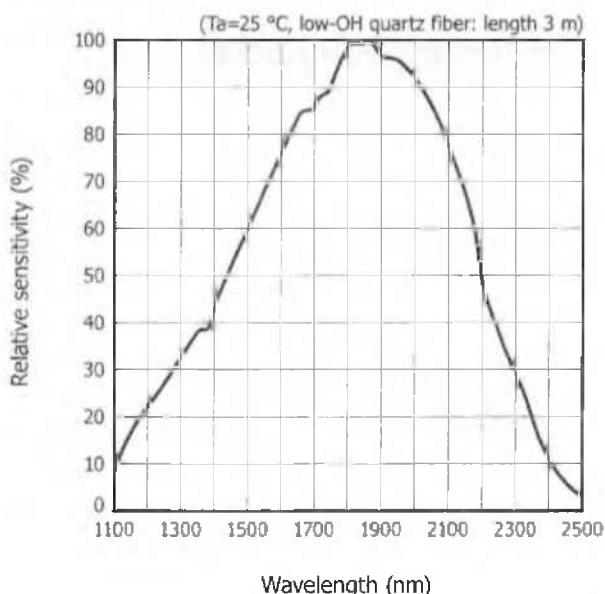
**▣ Spectral response (typical example)**

KACCR0619FA

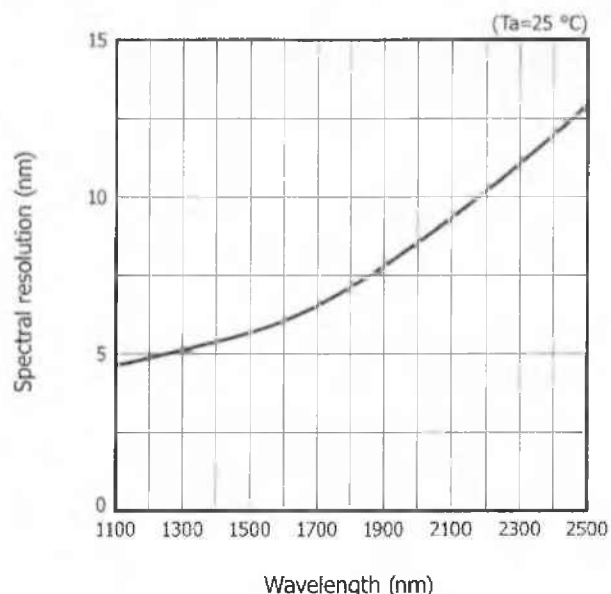
**▣ Spectral resolution vs. wavelength (typical example)**

KACCR0619FA



## FTIR engine

C15511-01

## S/N vs. gain setting (typical example)

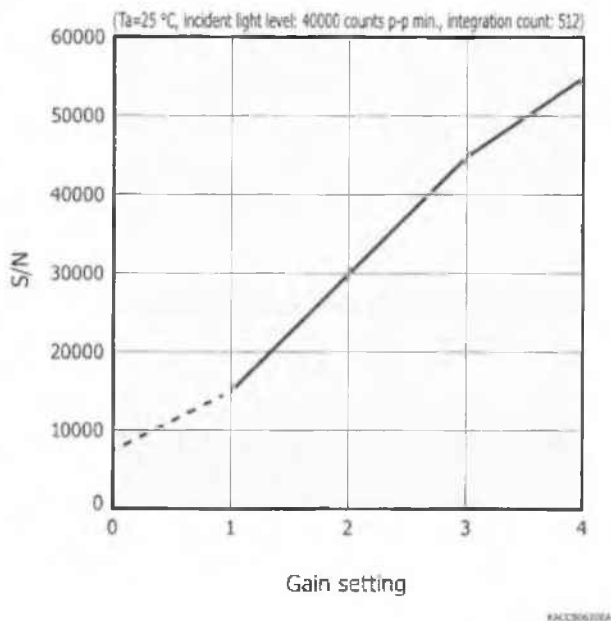

## Evaluation software (accessory)

By installing the evaluation software (HmFTIR02Main.exe) into a PC, you can perform the following basic operations.

- Acquire and save measured data
- Measurement condition setting
- Acquire module information (type no., serial number, spectral response range, etc.)
- Display graphs
- Arithmetic function
- Compare against reference data (absorbance and the like)

Note: Up to eight FTIR engines can be connected to a single PC and used.

Compatible OS: Microsoft® Windows® 10 (64-bit)

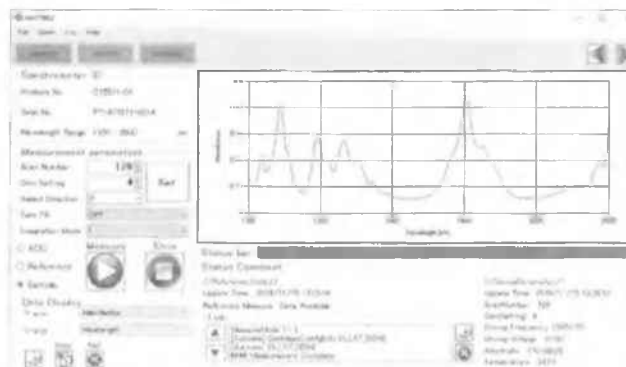

Microsoft and Windows are registered trademarks of Microsoft Corporation in the United States and/or other countries.

## Dimensional outline (unit: mm)

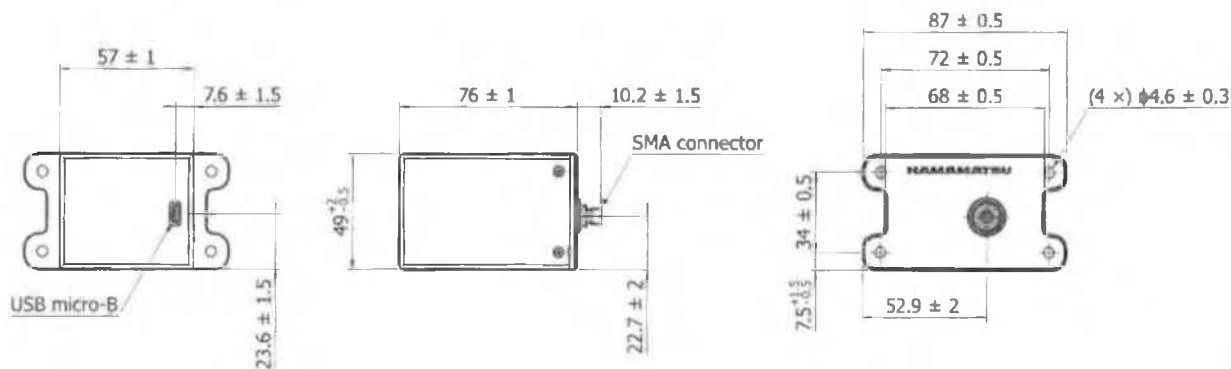

KAC006004

**FTIR engine****C15511-01****Precautions**

- Do not apply excessive vibration or shock to the product. Excessive vibration or shock can misalign the internal optical components of the product.
- This product is classified as Class 1 under the laser standard IEC60825-1: 2014. Do not disassemble the product to prevent laser light from entering your eyes.

**Accessories**

- CD-ROM (instruction manual, evaluation software, etc.)
- USB cable (USB 2.0 micro-B connector type)

**Options (sold separately)**

- Input optical fiber A16963-01

Type no.	Product name	Core diameter (μm)	Specifications
A16963-01	Fiber for visible/near infrared range	φ600	NA=0.22, length=1.5 m With SMA905D connector on each end

- Vibration isolation table A15835-01

- Vibration isolation table equipped with FTIR engine

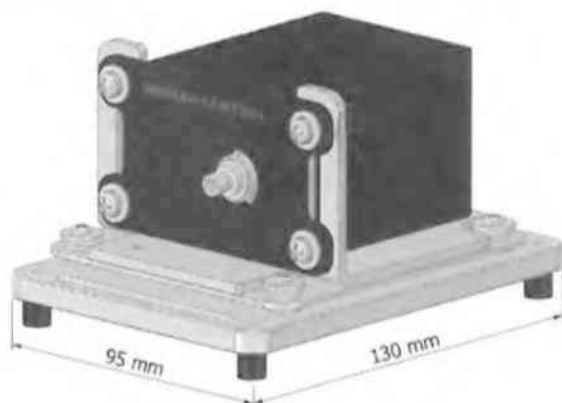

KACCC10255A

**Related information**

[www.hamamatsu.com/sp/ssd/doc\\_en.html](http://www.hamamatsu.com/sp/ssd/doc_en.html)

- Precautions
- Disclaimer

Information described in this material is current as of April 2024.

Product specifications are subject to change without prior notice due to improvements or other reasons. This document has been carefully prepared and the information contained is believed to be accurate. In rare cases, however, there may be inaccuracies such as text errors. Before using these products, always contact us for the delivery specification sheet to check the latest specifications.

The product warranty is valid for one year after delivery and is limited to product repair or replacement for defects discovered and reported to us within that one year period. However, even if within the warranty period we accept absolutely no liability for any loss caused by natural disasters or improper product use. Copying or reprinting the contents described in this material in whole or in part is prohibited without our prior permission.

**HAMAMATSU**[www.hamamatsu.com](http://www.hamamatsu.com)

HAMAMATSU PHOTONICS K.K., Solid State Division

1126-1 Ichino-cho, Chuo-ku, Hamamatsu City, 435-8558 Japan, Telephone: (81)53-434-3311, Fax: (81)53-434-5184

U.S.A.: HAMAMATSU CORPORATION: 360 Foothill Road, Bridgewater, NJ 08807, U.S.A., Telephone: (1)908-231-0960, Fax: (1)908-231-1218

Germany: HAMAMATSU PHOTONICS DEUTSCHLAND GMBH: Arzbergerstr. 10, 82211 Herrsching am Ammersee, Germany, Telephone: (49)8152-375-0, Fax: (49)8152-265-8 E-mail: info@hamamatsu.de

France: HAMAMATSU PHOTONICS FRANCE S.A.R.L.: 19 Rue du Saule Trape, Parc du Moulin de Massy, 91882 Massy Cedex, France, Telephone: (33)1 69 53 71 00, Fax: (33)1 69 53 71 10 E-mail: info@hamamatsu.fr

United Kingdom: HAMAMATSU PHOTONICS UK LIMITED: 2 Howard Court, 10 Tewin Road, Welwyn Garden City, Hertfordshire, AL7 1BW, UK, Telephone: (44)1707-294888, Fax: (44)1707-325777 E-mail: info@hamamatsu.co.uk

North Europe: HAMAMATSU PHOTONICS NORDEN AB: Torshamnsgatan 35, 16440 Kista, Sweden, Telephone: (46)8-509-031-00, Fax: (46)8-509-031-01 E-mail: info@hamamatsu.se

Italy: HAMAMATSU PHOTONICS ITALIA S.R.L.: Strada della Moia, 1 int. 6 70044 Arese (Milano), Italy, Telephone: (39)02-93 58 17 33, Fax: (39)02-93 58 17 41 E-mail: info@hamamatsu.it

China: HAMAMATSU PHOTONICS (CHINA) CO., LTD.: 1201, Tower B, Jiliming Center, 27 Dongqiangmen Beikou, Chaoyang District, 100020 Beijing, P.R. China, Telephone: (86)10-6586-6006, Fax: (86)10-6586-2866 E-mail: hpc@hamamatsu.com.cn

Taiwan: HAMAMATSU PHOTONICS TAIWAN CO., LTD.: 13F-1, No.151, Section 2, Gongde 5th Road, East Dist., Hsinchu City, 300096, Taiwan(R.O.C) Telephone: (886)3-659-0080, Fax: (886)3-659-0081 E-mail: info@hamamatsu.com.tw

# Diffuse reflection light source

L16462-01



## Near infrared (up to 2500 nm) light source for diffuse reflection measurement

The L16462-01 is a module with built-in lamps and an optical fiber for doing diffuse reflection measurement in near-infrared spectrophotometry. This module irradiates a sample with light from lamps, and the light that enters the sample and is diffused/reflected is introduced into the optical fiber. It is connected to a near-infrared spectrometer for use. With this product, in which plural lamps and an optical fiber are arranged close to each other, the weak diffused light emitted from the sample can be detected efficiently.

### Features

- **Compact:  $\phi 28.0$  mm  $\times$  35.5 mm**
- **Long life: 7000 hr (average)**
- **High detection efficiency (built-in multiple lamps)**
- **Wide wavelength range: 400 to 2500 nm**

### Applications

- **Spectrophotometry**
- **PAT: process analytical technology (medicine, food, etc.)**
- **Recycling (plastic, etc.)**

### Structure

Parameter		Specification	Unit
Tungsten lamp	Quantity	4	pcs
	Irradiation angle*1	Approx. 60	degrees
	Recommended supply voltage	+5	V
	Average lifetime*2	7000	hr
	Warranty lifetime*3	2000	hr
Focal position*4	With spacer attached	Approx. 0	mm
	With spacer detached	Approx. 3	mm
Built-in optical fiber angle*1		Approx. 90	degrees
Built-in optical fiber		Core diameter=1000 $\mu$ m, NA=0.22	-
Optical fiber connector		SMA905	-
Power connector		EGG.00.302.CLL (LEMO)	-
Dimensions (excluding protrusions)		$\phi 28 \times 35.5$	mm
Window material		Quartz glass	-

\*1: Angle with the light emission surface of the case

\*2: Average lifetime of lamp itself. Time until 50% of the lamps burn out, when the lamps are lit continuously at an ambient temperature of 25<sup>o</sup> C at the recommended supply voltage of 5 V.

\*3: Time after delivery, not lamp lighting time

\*4: Distance from the case light emission surface to the focal point. The focal point is the point where the light outputs of the four lamps overlap.

Note: There is a fee for replacement of burned out lamps. Please contact your local Hamamatsu sales office.

### Absolute maximum ratings (Ta=25 °C, unless otherwise noted)

Parameter	Symbol	Condition	Value	Unit
Operating temperature	Topr	No dew condensation*5	+5 to +50	°C
Storage temperature	Tstg	No dew condensation*5	-20 to +70	°C
Maximum supply voltage	Vin max		+6	V
Maximum input current	Iin max		550	mA

\*5: When there is a temperature difference between a product and the surrounding area in high humidity environments, dew condensation may occur on the product surface. Dew condensation on the product may cause deterioration in characteristics and reliability.

Note: Exceeding the absolute maximum ratings even momentarily may cause a drop in product quality. Always be sure to use the product within the absolute maximum ratings.

**Diffuse reflection light source****L16462-01****Electrical and optical characteristics (Ta=25 °C, Vin=5 V)**

Parameter	Min.	Typ.	Max.	Unit
Current consumption	385	460	515	mA
Wavelength range	-	400 to 2500	-	nm

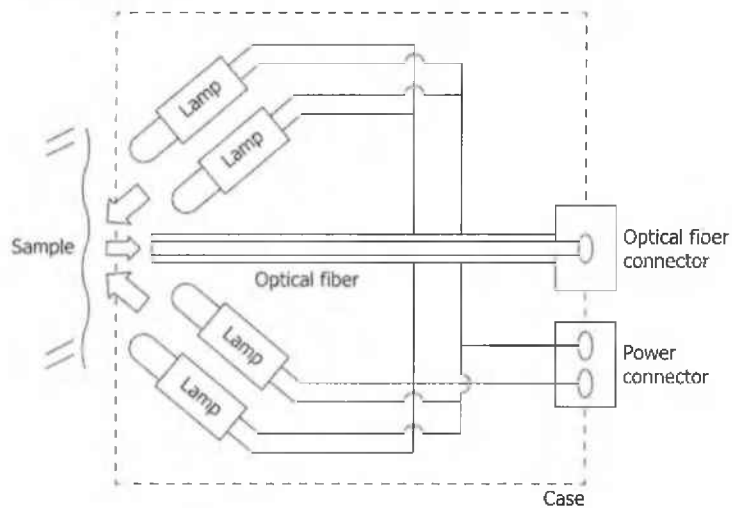
**Block diagram**

KACCC1181EA

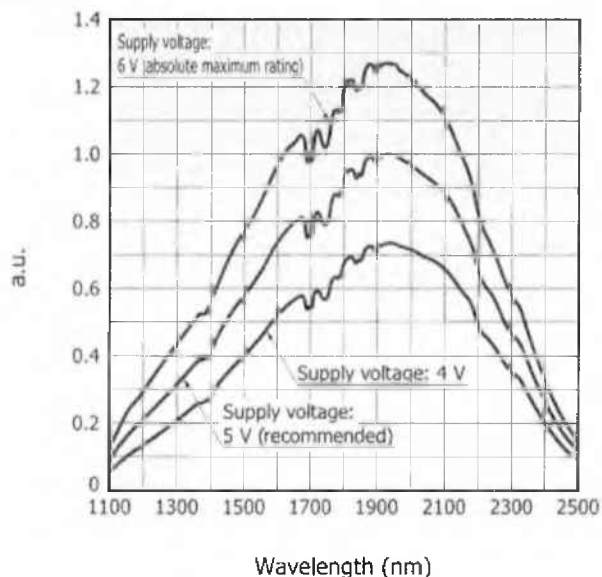
**Spectrum (when FTIR engine C15511-01 is used, typical example)**

KACCC131EA

**Diffuse reflection light source****L16462-01****Connection example**

A connection example using Hamamatsu FTIR engine (C15511-01) is shown below.

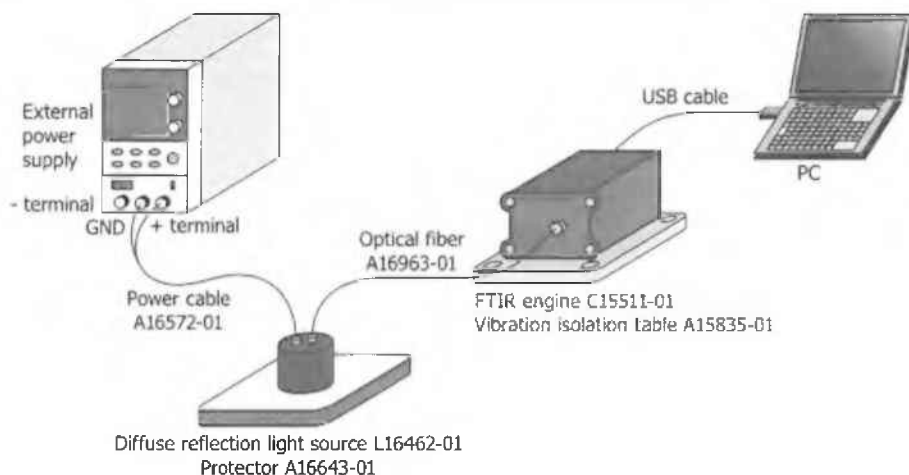

KACCC1187FB

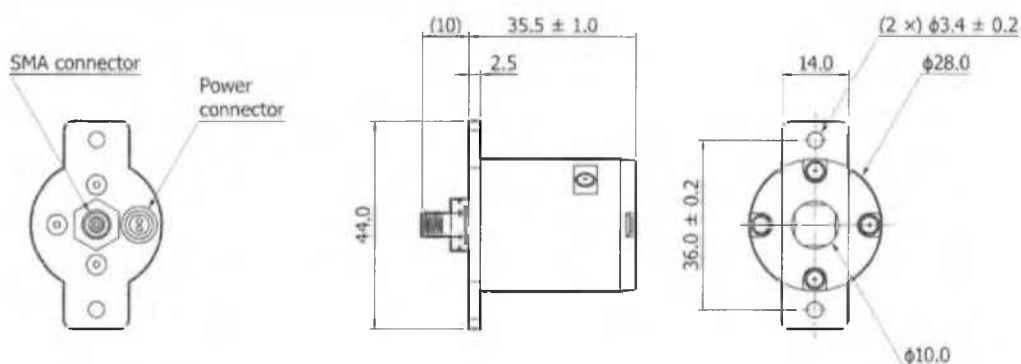
**Dimensional outline (unit: mm)**

Tolerance unless otherwise noted:  $\pm 0.5$   
Weight: 50 g

KACCA0450EA

**Accessories**

- CD-ROM (instruction manual)

**Diffuse reflection light source****L16462-01****Options (sold separately)**

## ■ Power cable (A16572-01)

Type no.	Name	Connector	Specification
A16572-01	Power cable	FGG.00.302.CLAD35	Length: 1.5 m One end: lead wire soldering Wire: AWG26

## ■ Optical fiber cable (A16963-01)

Type no.	Name	Core diameter ( $\mu\text{m}$ )	Specification
A16963-01	Visible/near infrared optical fiber	600	NA=0.22, length: 1.5 m With SMA905D connector on each end

## ■ Protector (A16643-01)

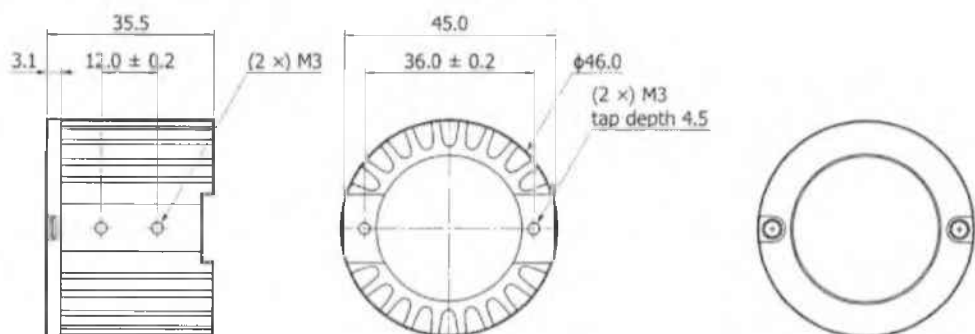

Accessories: M3 bolt (× 4), washer (× 4), spring washer (× 4)

Tolerance unless otherwise noted:  $\pm 0.5$   
Weight: 55 g

KACCA0491EA

## Diffuse reflection light source

L16462-01

### Related products

#### FTIR engine C15511-01



This is a compact Fourier transform type near-infrared spectrometer, with a built-in Michelson optical interferometer and a control circuit in a palm-sized case. Spectrum and absorbance can be measured by connecting a PC via USB.

#### Features

- ▶ **Compact: palm size**
- ▶ **Optical fiber input type**
- ▶ **No external power supply required (USB bus powered)**
- ▶ **High S/N: Suitable for diffuse reflection measurement and absorbance measurement**
- ▶ **Spectral response range: 1100 to 2500 nm**

#### Mini-spectrometer C14486GA



This is a spectrometer (polychromator) provided in a compact, thin case that houses optical elements, InGaAs image sensor, and driver circuit. The trigger function enables spectroscopic measurement of pulse emissions.

#### Features

- ▶ **Compact, thin case**
- ▶ **Optical fiber input type**
- ▶ **With trigger function**
- ▶ **No external power supply required (USB bus powered)**
- ▶ **Stores wavelength conversion factor\*6 in internal memory**
- ▶ **Spectral response range: 950 to 1700 nm**

\*6: A factor for converting the pixel numbers of the image sensor to wavelengths

### Precautions

- Do not look directly at the emitted light.

This product has built-in tungsten lamps that emit light in the visible to near-infrared region, from the light emitter. Light risk group: classified as exemption according to EN 62471/IEC 62471, but directly looking into the light for a long time or from a very close distance may impair visual function.

- Beware of high temperature.

The temperature of the case of this product rises when the lamp is turned on. If you touch this product for a long time after the lamps are on, your skin may become red, itchy, or develop a rash, and you may get burned. Avoid touching this product when it is hot, as much as possible.

- Do not apply overvoltage.

Applying a voltage or current that exceeds the absolute maximum ratings even momentarily may damage the built-in lamps, so that they cannot be turned on. Make sure to use the product within the absolute maximum ratings. If the lamps are damaged due to overvoltage or overcurrent, there will be a fee for replacement of the lamps even if the lamps are still within its warranty life. Please contact your local Hamamatsu sales office.

**Diffuse reflection light source****L16462-01****Related information**[http://www.hamamatsu.com/sp/ssd/doc\\_en.html](http://www.hamamatsu.com/sp/ssd/doc_en.html)

- Precautions
- Disclaimer

The content of this document is current as of March 2024.

Product specifications are subject to change without prior notice due to improvements or other reasons. This document has been carefully prepared and the information contained is believed to be accurate. In rare cases, however, there may be inaccuracies such as text errors. Before using these products, always contact us for the delivery specification sheet to check the latest specifications.

The product warranty is valid for one year after delivery and is limited to product repair or replacement for defects discovered and reported to us within that one year period. However, even if within the warranty period we accept absolutely no liability for any loss caused by natural disasters or improper product use. Copying or reprinting the contents described in this material in whole or in part is prohibited without our prior permission.

**HAMAMATSU**[www.hamamatsu.com](http://www.hamamatsu.com)

HAMAMATSU PHOTONICS K.K., Solid State Division

1126-1 Ichino-cho, Chuo-ku, Hamamatsu City, 435-8558 Japan, Telephone: (81)53-434-3311, Fax: (81)53-434-5184

U.S.A.: HAMAMATSU CORPORATION, 360 Foothill Road, Bridgewater, NJ 08807, U.S.A., Telephone: (1)908-231-0960, Fax: (1)908-231-1218

Germany: HAMAMATSU PHOTONICS DEUTSCHLAND GMBH, Arzbergstr. 10, 82211 Herrsching am Ammersee, Germany, Telephone: (49)8152-375-0, Fax: (49)8152-265-8 E-mail: [info@hamamatsu.de](mailto:info@hamamatsu.de)

France: HAMAMATSU PHOTONICS FRANCE S.A.R.L., 19 Rue du Saule Trappi, Parc du Moulin de Massy, 91882 Massy Cedex, France, Telephone: (33)1 69 53 71 00, Fax: (33)1 69 53 71 10 E-mail: [Info@hamamatsu.fr](mailto:Info@hamamatsu.fr)

United Kingdom: HAMAMATSU PHOTONICS UK LIMITED, 2 Howard Court, 10 Tewin Road, Welwyn Garden City, Hertfordshire, AL7 1BW, UK, Telephone: (44)1707-294888, Fax: (44)1707-325777 E-mail: [info@hamamatsu.co.uk](mailto:info@hamamatsu.co.uk)

North Europe: HAMAMATSU PHOTONICS NORDEN AB, Torshamnsgatan 35, 16440 Kista, Sweden, Telephone: (46)8-509-031-00, Fax: (46)8-509-031-01 E-mail: [Info@hamamatsu.se](mailto:Info@hamamatsu.se)

Italy: HAMAMATSU PHOTONICS ITALIA S.R.L., Strada della Moia, 1 int. 6 20044 Arese (Milano), Italy, Telephone: (39)02-43 58 17 33, Fax: (39)02-93 58 17 41 E-mail: [info@hamamatsu.it](mailto:info@hamamatsu.it)

China: HAMAMATSU PHOTONICS (CHINA) CO., LTD., Tower B, Jiaming Center, 27 Dongsanhuai Beilu, Chaoyang District, 100020 Beijing, P.R. China, Telephone: (86)10-6586-6006, Fax: (86)10-6586-2866 E-mail: [hpc@hamamatsu.com.cn](mailto:hpc@hamamatsu.com.cn)

Taiwan: HAMAMATSU PHOTONICS TAIWAN CO., LTD., 13F-1, No.101, Section 2, Gongqiao 5th Road, Foshou Dist., Hsinchu City, 300046, Taiwan (R.O.C.) Telephone: (886)3-659-0080, Fax: (886)3-655-0081 E-mail: [info@hamamatsu.com.tw](mailto:info@hamamatsu.com.tw)