

joinery machines

# class range

classical machines for the advanced joinery



REV. N. 01 - 03.2021 - MFC STUDIO



SCM GROUP SPA  
via Casale 450 - 47826 Villa Verucchio, Rimini - Italy  
tel. +39 0541 674111 - fax +39 0541 674274  
scm@scmgroup.com  
www.scmwood.com



00L0590133G



# All “Made in SCM Italy”

## From casting iron to finished product.

Come see our production plants and touch the quality of SCM machines; you will be our guest.



### Classical machines for the advanced joinery.

SCM's objective is to guarantee customers high quality technologies which meet their requirements in such a way as to make SCM the partner for any needs.

## class range

The best solution for every application.

circular saws	programmable	<b>class si x</b> page 6	<b>class si 550ep</b> page 7	<b>class si 400ep</b> page 7	<b>class px 350i</b> page 22
	manual	<b>class si 400</b> page 8	<b>class si 350</b> page 9	<b>class si 300</b> page 9	
automatic multiblade rip saw		<b>class m 3</b> page 26			
planers	surface planers	<b>class f 520</b> page 30	<b>class f 410</b> page 30		
	thickening planers	<b>class s 630</b> page 31	<b>class s 520</b> page 31		
spindle moulders	electronically and programmable	<b>class ti 145ep</b> page 38	<b>class ti 120e</b> page 39	<b>class ti 130e</b> page 39	
	manual	<b>class tf 130</b> page 40	<b>class tf 130ps</b> page 41	<b>class ti 120</b> page 41	

The motors powers in this catalogue are expressed in S6, except where otherwise specified. In this catalogue, machines are shown in CE configuration and with options.

We reserve the right to modify technical specifications without prior notice, provided that such modifications do not affect safety as per CE norms.



# APP Thundercut

Technology at your fingertips

SCM Thundercut is the Optimizer/Sequencer App for mobile devices that allows to optimize the panel surface and guides the operator through the cutting sequence.

High cut speed execution, less material waste and mistake odds minimized, even for not skilled workers!

Download it now from the AppStore and Google Play:

SCM Thundercut



technologycenter

## SCM CLASSICAL MACHINES, QUALITY EVEN MORE GUARANTEED

Since 1952, SCM has been leader in the design and production of woodworking machines.

We are getting closer to reach 70 years of company history by offering to our customers knowledge and advanced technologies that distinguish **L'invincibile, class** and **nova** classical machines.

Different ranges united by the strength points: performance, ease-of-use and certified quality. We believe so much in the reliability of our machines to offer to our customers the possibility to have a **warranty extended up to 2 years\***. An extra peace of mind for small artisans workshops and joineries who see SCM as the ideal partner to grow their business.

To activate the 2-year warranty extension, it is compulsory to register on-line the machine on the website:

[scmwood.com/warranty-extension](http://scmwood.com/warranty-extension)

\*Check the models of machines that can take advantage of the initiative on the website:

[scmwood.com/joinery-machines](http://scmwood.com/joinery-machines)

You can manage your circular saws fleet, the material warehouse and many project you are working on.



The 3D sequencer, thanks to its simple and clear design, suggest the ideal settings of the machine for every single cut to be executed.

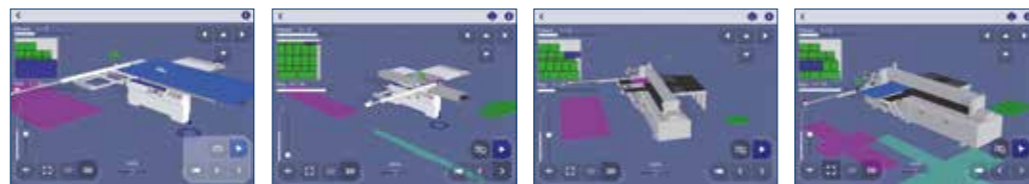

The App is available for circular saws, circular saws with movable blade unit, saw-shaper combination machines and universal combination machines (you will find the QR code to activate the App in each new machine).





programmable  
circular saws  
class si x  
class si 550ep  
class si 400ep



±46° double tilting blade.

		class si x	class si 550ep	class si 400ep
Max. saw blade diameter	mm	550	550*	400
Max. saw blade diameter <b>with installed scoring unit</b>	mm	450**	-	400
Max. saw blade projection from the table at 90°/45°/45°	mm	200/130/105	200/130/-	140/97/-
Saw blade rotating speed	rpm	3000 ÷ 5000	2500/3500/5000	3000/4000/5000
Squaring stroke	mm	2200 ÷ 3800	2200 ÷ 3800	2200 ÷ 3800
Cutting width on rip fence	mm	1000 ÷ 1500	1000 ÷ 1500	1000 ÷ 1500
Three-phase motors power starting from	kW/Hz	9 (11) / 50 (60)	7 (8) / 50 (60)	7 (8) / 50 (60)

Find the complete technical specification at page 20

\* The machine is not equipped with scoring unit

\*\* Scoring unit as option



Saw Unit  
sturdy structure

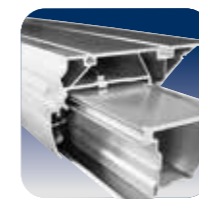

Sliding Carriage  
high cutting quality



Rip Fence  
smoothness and  
precision



Electronic Control  
precision and  
ease-of-use



SCM  
Thundercut  
Optimizer/  
Sequencer App

Superior technology combined  
with an ease-of-use.



manual  
circular saws  
class si 400  
class si 350  
class si 300



		class si 400	class si 350	class si 300
Max. saw blade diameter <b>with installed scoring unit</b>	mm	400	350	315
Max. saw blade projection from the table at 90°/45°	mm	140/97	118/81	100/70
Saw blade rotating speed	rpm	3000/4000/5000	4000	4000
Squaring stroke	mm	2200 ÷ 3800	2200 ÷ 3800	2200 ÷ 3800
Cutting width on rip fence	mm	1000 ÷ 1500	1000 ÷ 1500	1000 ÷ 1500
Three-phase motors power starting from	kW/Hz	7 (8) / 50 (60)	7 (8) / 50 (60)	5 (6) / 50 (60)

Find the complete technical specification at page 20

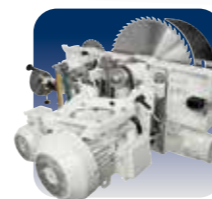

Saw Unit  
sturdy structure

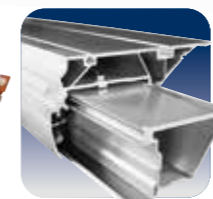

Sliding Carriage  
high cutting quality



Rip Fence  
smoothness and  
precision



SCM  
Thundercut  
Optimizer/  
Sequencer App

High construction quality for reliability and safe performance.

# circular saws operating groups

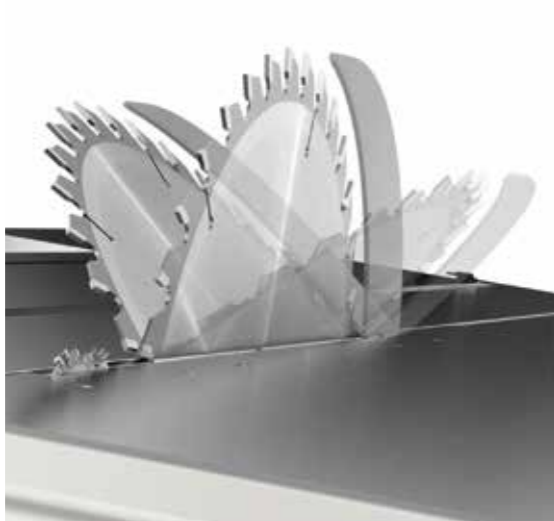

always user friendly and precise  
**Handwheels on the machine front**  
 Ease-of-use in every day operation due to the dedicated gear box (**SCM solution**), fully protected from dust, that provides a smooth and direct transmission. Every minimum hand-wheel movement corresponds to a precise blade adjustment.

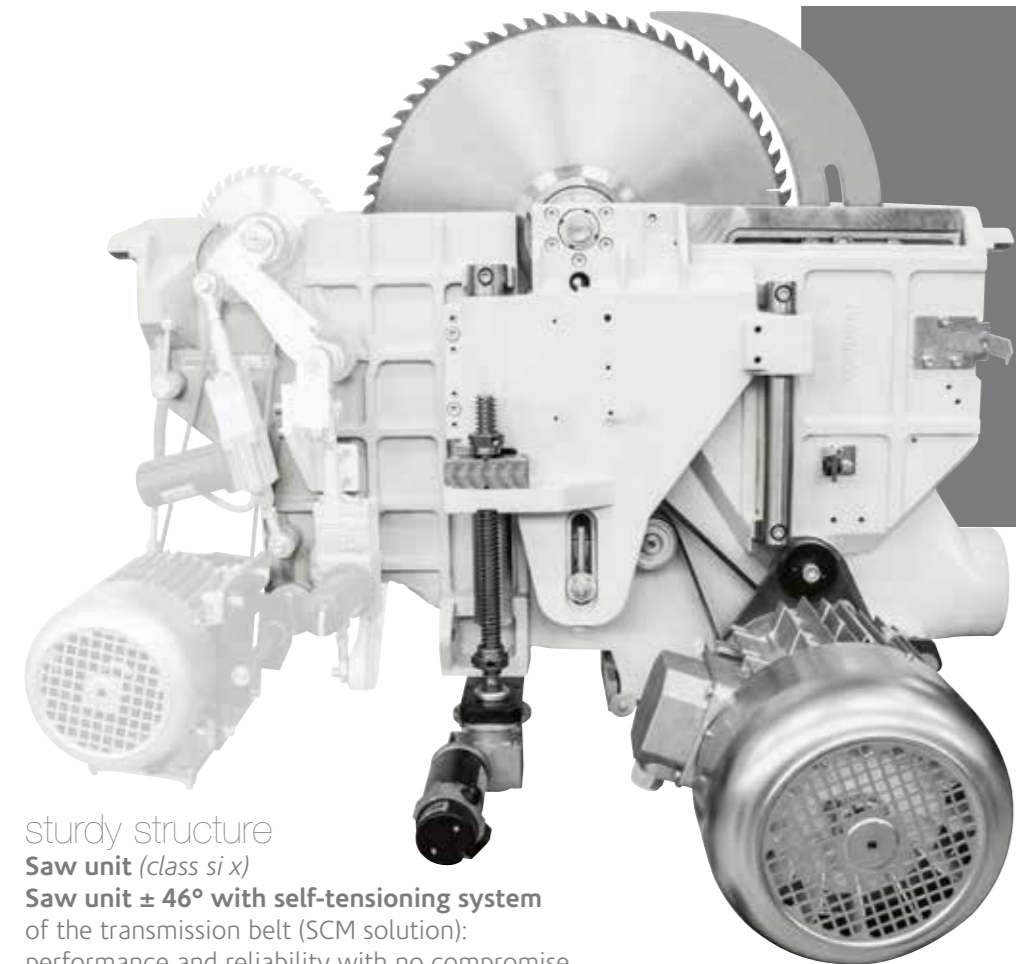

sturdy structure  
**Saw unit (class si x)**  
**Saw unit  $\pm 46^\circ$  with self-tensioning system** of the transmission belt (**SCM solution**): performance and reliability with no compromise.

The saw blade lifting is carried out by a strong cast-iron structure with sliding on ground round slideways which guarantee the **best accuracy**. The unit tilting is carried out on cast-iron rotation sectors in a crescent shape to ensure reliability over time.



simple and effective  
**Scoring unit adjustment**  
 Vertical and horizontal adjustments are carried out by user-friendly mechanical levers that operate directly making precise and smooth movements. The useful mechanical stops allow immediately finding of the set position. The positioning of the controls allows their use without moving from the front of the machine.

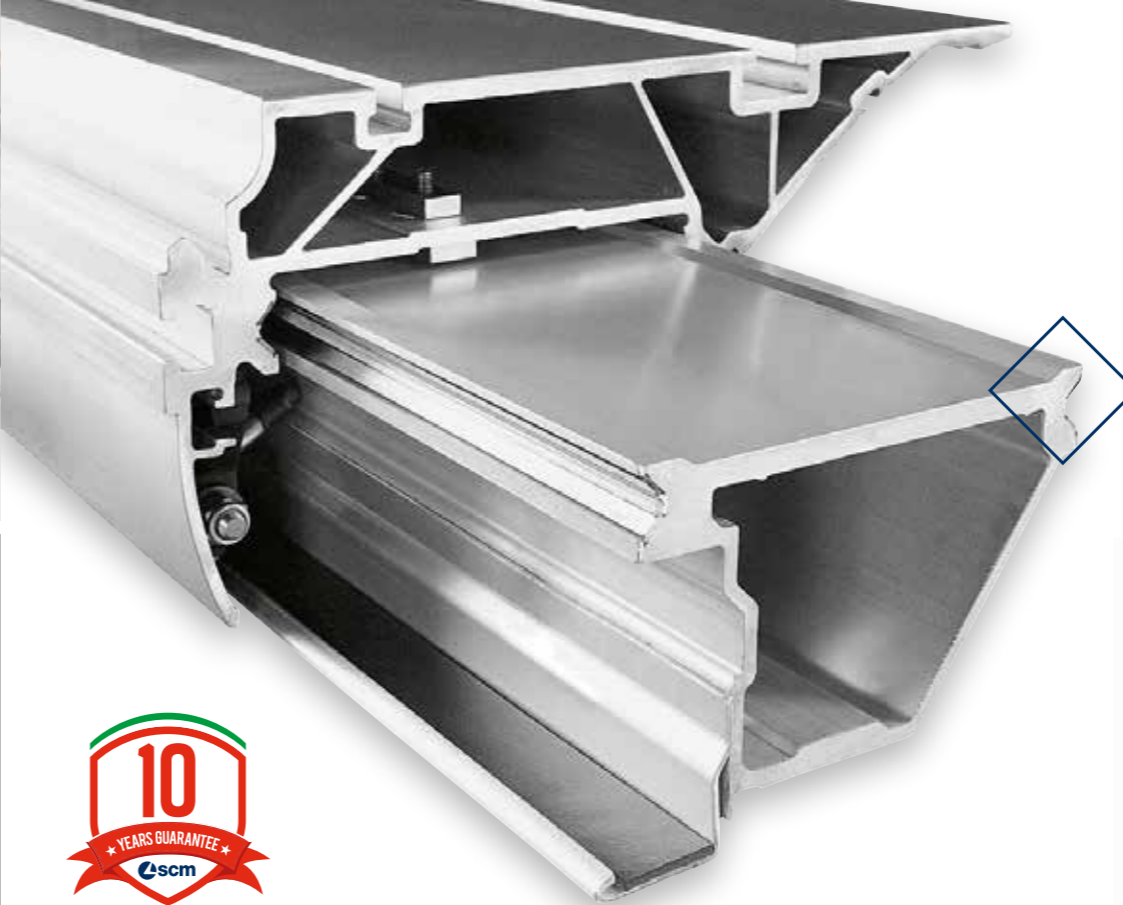

maximum cut quality guaranteed over time  
**Sliding carriage**  
 The carriage will never require adjustment due to its closed reticular geometry with steel guides using an **exclusive method of mechanical fixing**.



Furthermore, the "arc" profile of the class arch-ground steel slideways (**SCM solution**) ensures:

- No play and loads four times higher than others
- $\pm 0,05$  mm tolerance on the entire carriage length for straight and high quality cutting
- Sliding effectiveness over time, thanks to the particular guides positioning which ensures protection from dust



reliability and technology without comparison  
 10 years of SCM guarantee for the carriage sliding system.



optimal support  
**Squaring frame and fence**  
 Panel loading is easy on the large squaring frame with an idle roller at the end and the mobile cross beams offer an **optimal support** also to smaller panels. The telescopic squaring fence with the inclined metric scale and two reversible stops can be used to square panels measuring 3200x3800 mm and for tilted cuts at up to  $45^\circ$  on both sides of the frame.



smooth, rapid and precise positioning  
**Rip fence**  
 Sliding of the rip fence support on round bar with micrometric adjustment. The support can be also equipped with digital readout for fence position with detecting system on magnetic band (option). The fence can be easily excluded from the working area when it isn't used.

# programmable circular saws electronic controls

Technical specification at page 21



the practical advantage for automatic control of the main positions

## Ready

The **programming** of the work becomes **simple and effective** with the electronic control with a 4" LCD display.

- Working mode: manual, semi-automatic and automatic with a memory capacity of up to 99 programs
- Tool data setting with automatic height adjustment
- Calculator and hour counter



Saw unit lifting



Saw unit tilting



Programmable rip fence (option)



Blade speed readout

the operating advantage for easy assistance

## Easy

**Maximum reliability** due to the function pushbuttons and easy to use with the electronic control of up to 5 axes with the 7" LCD display, 16:9 format. Integrated and fast control of all dedicated functions. These features translate into immediate improvements in productivity and guarantees the capability of the full potential of the machine.



one cut only, the correct one

## Operator's support

The large display suggests to the operator information for the correct use of any cutting configuration. In particular, it displays in real time the correct position of the stop on the basis of the known measurements of the work-piece (**SCM solution**).

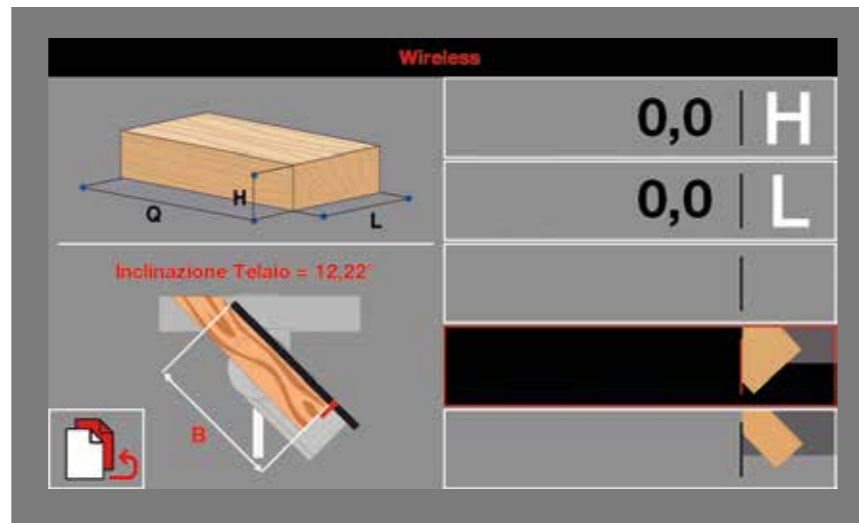

Easy control can easily manage the inverter for the adjustment of the saw blade rotation speed and the scoring unit alignment.



speed and accuracy

**Motorised programmable rip fence mounted on a recirculating ball screw mechanism with sliding on linear guides.**

*Only for Ready 3 Plus / Easy 3 Plus versions*



the innovation at the operator service

## Automatic positioning system of the overhead protection

The overhead protection automatically positions itself as a function of the blade using the **exclusive "AP system" (SCM solution)**.

This makes the transition from cuts with different angles even faster and safe, without the operator having to change the settings of the machine.

*(class si x)*

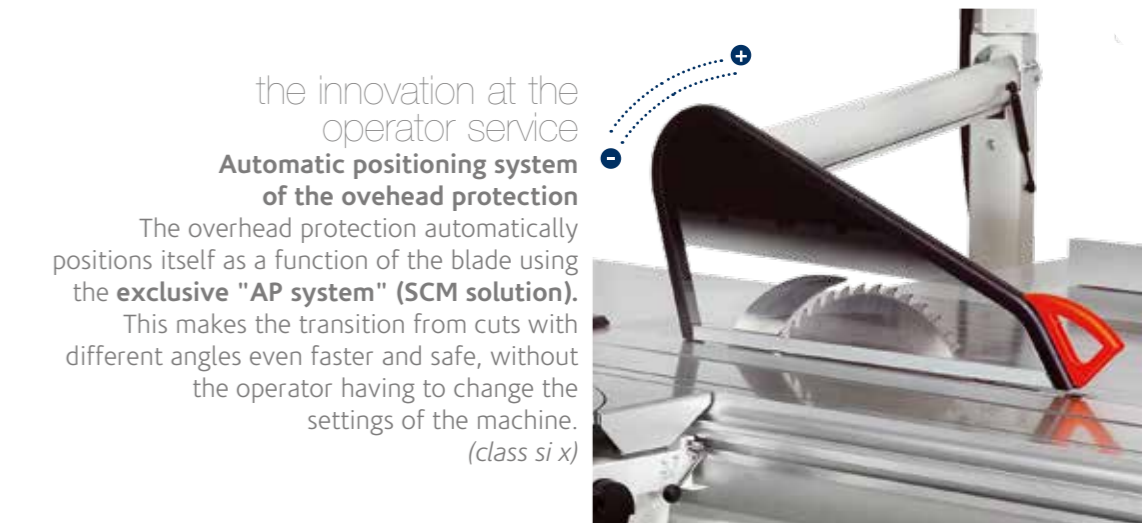

practicality and safety

**Motorized programmable rip fence with steel cable and sliding on sturdy round steel bar.**

Position readout on magnetic band.

*Only for Ready 3 version*



circular  
saws  
main  
optional  
devices

**Angular cutting devices**  
Available for the following versions  
a) traditional  
b) with automatic self-adjustment of the stops position in respect of the blade  
c) with automatic self-adjustment of the stops position in respect of the blade and electronic readouts for stop position and rule tilting angle



**Rip fence unit**  
The exclusive referencing system for the first trim cut allows the setting of trim quantity to be cut for every side without any test cuts. Available also with electronic readouts.

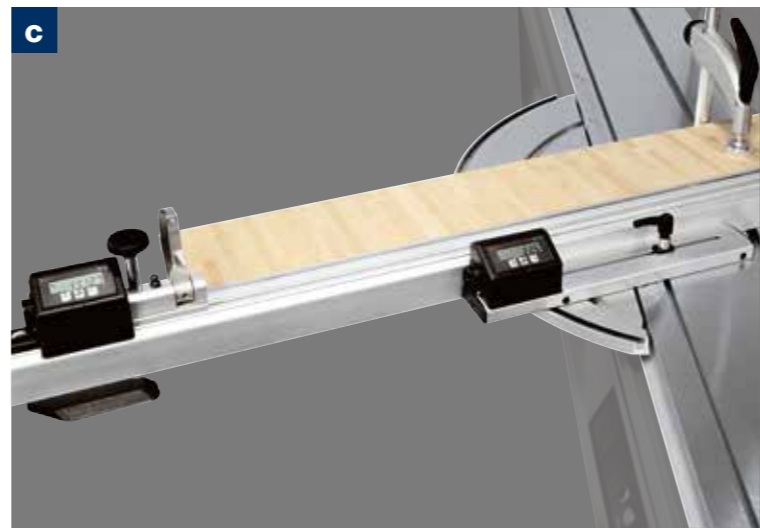
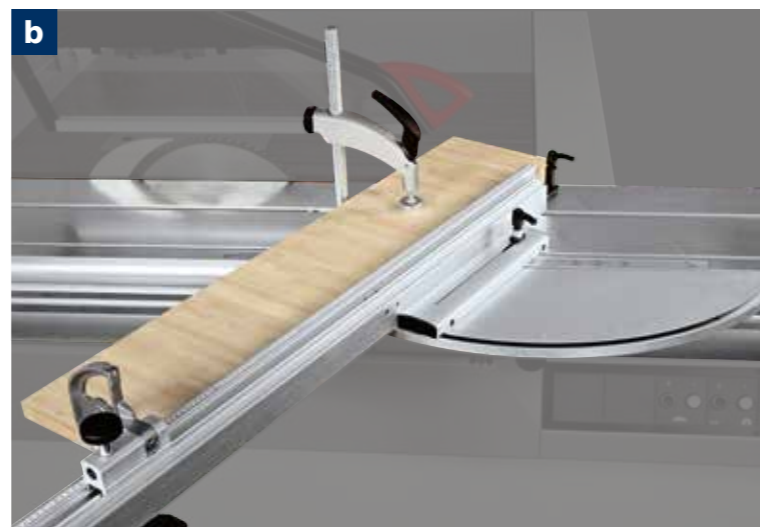

**Squaring frame with "Complex" device**  
with automatic self-adjustment of stops position in respect of the blade and rule tilting angle. Furthermore, thanks to the dedicated frame structure, it is possible to carry out **tilted cuts keeping the squaring rule comfortably within the operator's reach**, both in acute cuts and in obtuse ones, without renouncing to a valid support of the piece.

speed and precision  
**"Quick Lock" squaring fence with rapid release.**  
Minimum set-up time with the **SCM system that allows rapid fence positioning.**  
The extending roller and the stronger frame support maximise performance.

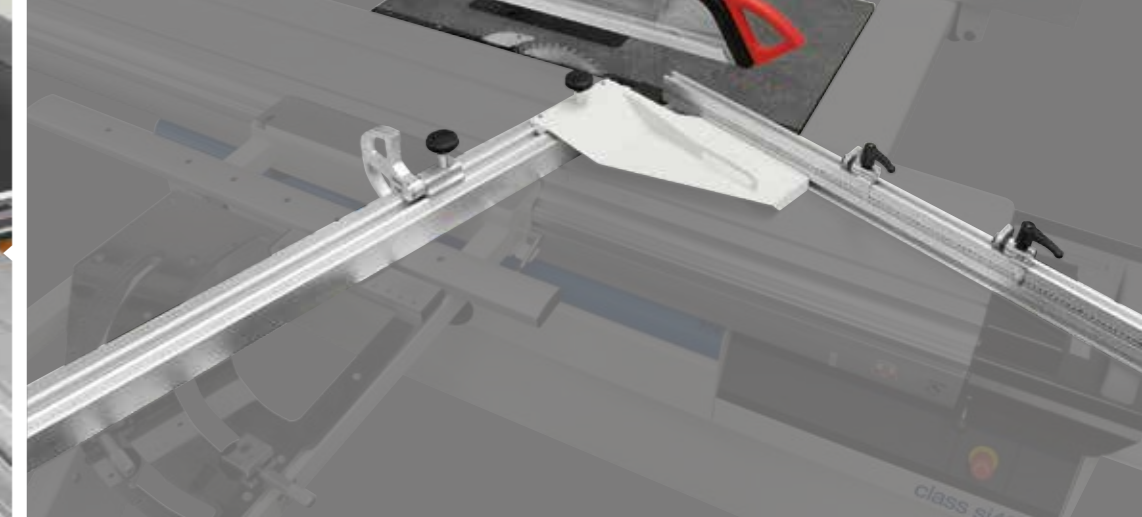

**Fence for complementary cutting**  
Device to be applied directly on the squaring rule that allows to quickly carry out cuts with angles complementary to the rule one.

**Electronic readouts on the squaring stops**  
The stops can be easily read even from distance.



**circular  
saws  
main  
optional  
devices**

**Surface reinforcement treatment**  
For sliding table and mobile crossbars of squaring frame.  
Dedicated to the intensive processing and particularly abrasive materials.



**circular  
saws  
main  
optional  
devices**

**Tablet holder on the sliding carriage**  
Compatible with tablets from 8" to 11".



**Extension with roller conveyor on parallel fence side,**  
for the support of large panels, and tools-holder  
to have the tools always within reach.



**Mechanical preset for "DADO" machining**  
Possibility of using a tool (not included) to replace the main blade, with 203 mm maximum diameter and 20 mm maximum thickness.



**Adjustable tablet holder positioned on the mobile control panel**  
Compatible with tablets from 7" to 13".  
It is equipped with USB port for power supply positioned on the mobile control panel.

**circular  
saws**  
main  
optional  
devices



**Blades-holder drawer integrated in the machine's frame**  
It is made of 4 shelves, customizable with labels, for the easy replacement of the blades.

**Pneumatic presser**  
Particularly suitable for the cutting of thin materials.



**Advanced materials machining**  
PVC and other plastic materials. Nylon, polycarbonate and other synthetic materials. Corian and other composite materials. Aluminium, brass and other light metals.

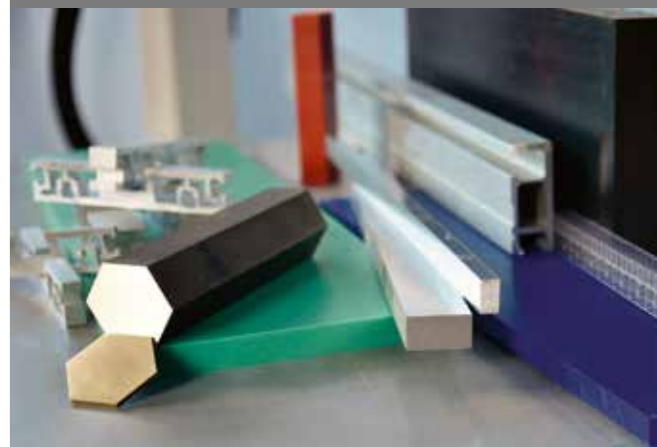

**"Pro-Lock"**  
System for the main blade rapid locking with fast and tool-less riving knife adjustment.



**Expandable scoring blade**  
Manually expandable with variable thickness from 2,8 to 3,6 mm. Blade diameter: 120 mm (160 mm for *class si x*)



**Second extension with sliding rail support**  
to safely support panels for large dimension and weight.



**Device for the blade micro-lubrication**  
Compulsory for the machining of light alloys, extremely useful with particular plastic materials.



**"LED indicating scoring unit in operation" device**  
When the scoring blade is working, the high efficiency LEDs clearly indicate the danger area, making the machine safer than ever.



# circular saws technical data

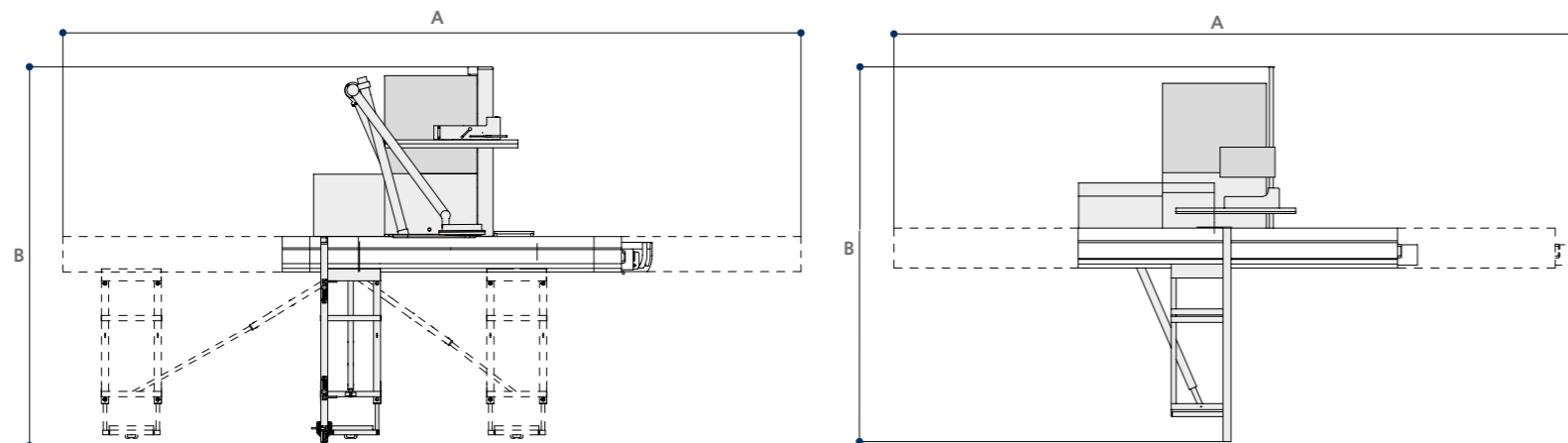

S Standard  
O Option

TECHNICAL DATA		class si x	class si 550ep	class si 400ep	class si 400	class si 350	class si 300
Cast-iron saw table dimensions	mm	1285 x 700	1285 x 700	1040 x 630	1040 x 630	1040 x 630	900 x 550
Blades tilting	mm	-46° ÷ +46°	90° ÷ 45°	90° ÷ 45°	90° ÷ 45°	90° ÷ 45°	90° ÷ 45°
Max. saw blade diameter		550	550*	400	400	350	315
Max. saw blade diameter <b>with installed scoring unit</b>	mm	450**	-	400	400	350	315
Max. saw blade projection from the table at 90°/+45°/-45°	mm	200/130/105	200/130/-	140/97/-	140/97/-	118/81/-	100/70/-
Saw blade rotating speed	rpm	3000 ÷ 5000	2500/3500/5000	3000/4000/5000	3000/4000/5000	4000	4000
Squaring stroke	mm	2200 ÷ 3800	2200 ÷ 3800	2200 ÷ 3800	2200 ÷ 3800	2200 ÷ 3800	2200 ÷ 3800
Cutting width on rip fence	mm	1000 ÷ 1500	1000 ÷ 1500	1000 ÷ 1500	1000 ÷ 1500	1000 ÷ 1500	1000 ÷ 1500
<b>other technical features</b>							
Three-phase motors 5 kW (6,6 hp) 50 Hz - 6 kW (8 hp) 60 Hz		-	-	-	-	-	S
Three-phase motors 7 kW (9,5 hp) 50 Hz - 8 kW (11 hp) 60 Hz		-	S	S	S	S	O
Three-phase motors 9 kW (12 hp) 50 Hz - 11 kW (15 hp) 60 Hz		S	O	O	O	-	-
Three-phase motors 14 kW (19 hp) 50 Hz - 14 kW (19 hp) 60 Hz		-	O	-	-	-	-
Exhaus hoods diameter:							
- at the base	mm	120	120	120	120	120	120
- on overhead protection	mm	100	100	100	100	100	100
- on riving knife	mm	-	-	60	60	60	60

\* The machine is not equipped with scoring unit

\*\* Scoring unit as option

OVERALL DIMENSIONS		class si x	class si 550ep	class si 400ep	class si 400	class si 350	class si 300
A with 2200 mm carriage	mm	5230	5230	5230	5090	5090	5090
A with 3200 mm carriage	mm	7250	7250	7250	6825	6825	6825
A with 3800 mm carriage	mm	8500	8500	8500	7425	7425	7425
B with 1000 mm cutting width on rip fence	mm	4042	3922	3815	3740	3740	3597
B with 1270 mm cutting width on rip fence	mm	4367	4247	4140	4110	4110	3867
B with 1500 mm cutting width on rip fence	mm	4492	4372	4265	4235	4235	4097

MAIN OPTIONAL DEVICES		class si x	class si 550ep	class si 400ep	class si 400	class si 350	class si 300
"Ready 3" version		-	O	O	-	-	-
"Ready 3 UP" / "Ready 3 UP Plus" version		-	-	O	-	-	-
"Easy" version		S	-	-	-	-	-
"Easy 3 UP Plus" version		O	-	O	-	-	-
"SCM Thundercut" Optimizer/Sequencer App		S	S	S	S	S	S
Expandable scoring blade		O	-	O	O	O	O
Surface reinforcement treatment for sliding table		O	O	O	O	O	O
Pushbuttons integrated in the sliding carriage		O	O	O	O	O	O
"Quick Lock" squaring fence		O	O	O	O	O	O
Squaring fence with LCD readouts for stops position		O	O	O	O	O	O
Fence for angular cutting on the sliding carriage		O	O	O	O	O	O
Fence for angular cutting with self-adjustment		O	O	O	O	O	O
Fence for angular cutting with electronic readouts and self-adjustment		O	O	O	O	O	O
Squaring frame with "Compex" device		O	O	O	O	O	O
Fence for complementary cutting		O	O	O	O	O	O
Fence for rip cutting on the sliding carriage		O	O	O	O	O	O
Fence for rip cutting on the sliding carriage with electronic readout		O	O	O	O	O	O
Inverter for electronic speed change from 2700 to 6000 rpm		S**	-	O	-	-	-
2-axis automatic adjustment of the scoring unit		S***	-	O	-	-	-
Electronic readout of parallel fence position		O	O	O	O	O	O
Presser on entire carriage length		O	O	O	O	O	O
Second extension with sliding rail support		O	O	O	O	O	O
Extension with roller conveyor on parallel fence side		O	O	O	O	O	O
"Pro-Lock" system for the main blade rapid locking		O	O	O	O	-	-
"LED indicating scoring unit in operation" device		O***	-	O	-	-	-
"DADO" machining		-	-	O	O	O	O
Machine configuration for advanced materials machining		O	-	O	O	O	O
Device for the blade micro-lubrication for the machining of plastic materials and light alloy		O	-	O	O	O	O
Overhead blades protection		S	S	S*	S*	O	O
Adjustable tablet holder positioned on the mobile control panel		O	-	O	-	-	-
Tablet holder on the sliding carriage		O	O	O	O	O	O
Blades-holder drawer integrated in the machine's frame		O	-	-	-	-	-

\* Standard for CE and USA-Canada versions; Option for NO CE version

\*\* 3000 ÷ 5000 rpm speed

\*\*\* Scoring unit as option

circular saw  
with  
tiltable blade  
class px 350i

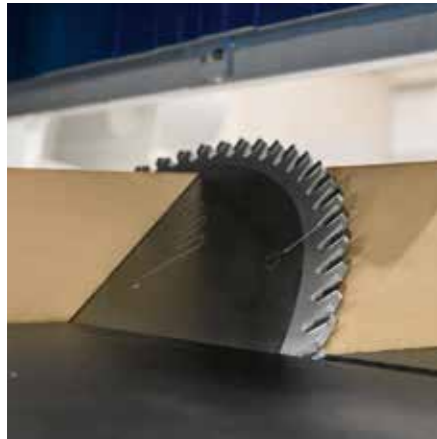

Blade tilting up to 46°.

Max. saw blade diameter	mm	class px 350i 350
Max. saw blade projection from the table at 90°/45°	mm	105/72
Saw blade rotating speed	rpm	4000
Squaring stroke	mm	2600 ÷ 3800
Cutting width on rip fence	mm	1300
Three-phase motor power starting from	kW/Hz	5,5 (6,6) / 50 (60)

*Find the complete technical specification at page 25*



**Saw Unit**  
optimal finish

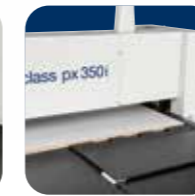

**Rear Stop**  
immediate  
positioning



**Ready**  
simple and rapid  
programmings



**SCM  
Thundercut**  
Optimizer/  
Sequencer App

Circular saw with mobile carriage and tiltable blade up to 46° to operate in safety with working space reduced up to 50% compared to a traditional circular saw.

class px 350i  
operating  
groups  
and main  
devices

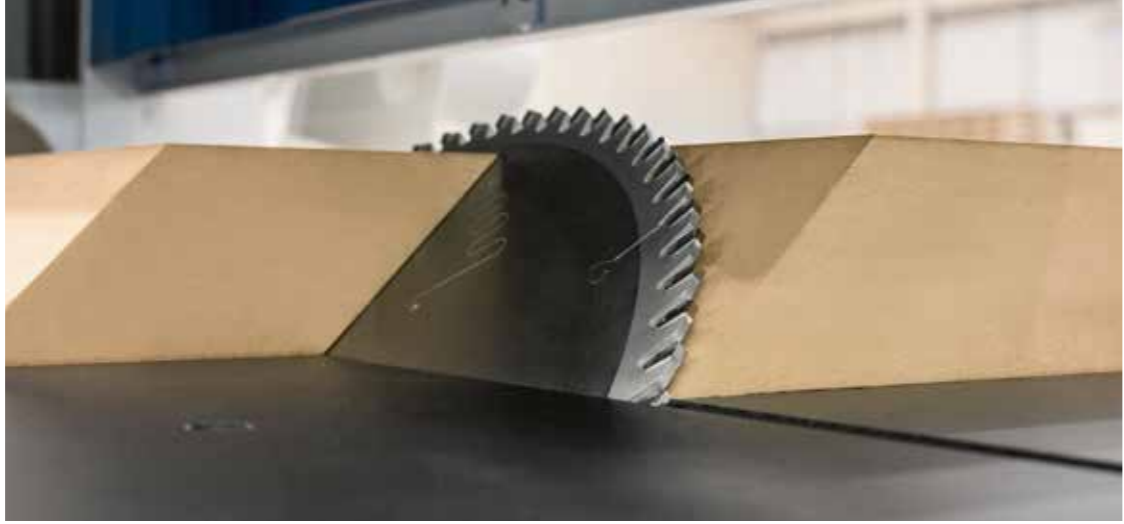

class px 350i  
technical  
data

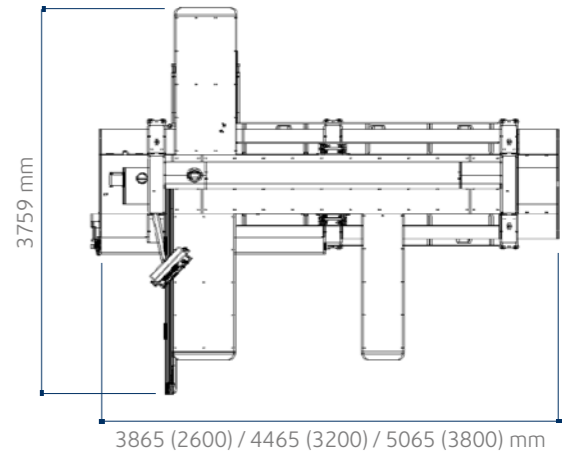

☐ Standard  
● Option

Simple and rapid  
Programmed movement with the  
"Ready" mobile control panel.



Sturdy telescopic squaring fence with the tilted metric scale towards the operator and the 2 reversible stop: panels squaring up to 2500x3000 mm (3200x3200 mm as option). The fixed table of large dimensions guarantees a stable panel support when machined.



Enlarged rear table  
equipped with 2 powered stops  
distributed on a length of 2000 mm,  
it simplifies the cutting of long and  
narrow panels.  
*(option)*



Immediate and precise positioning  
thanks to the powered and  
programmed rear stop.



Digital readouts  
available for squaring fence, fence for angular  
cutting and device for rip cuts.  
*(option)*

Fence for angular cutting  
It includes two  
reversible stops.  
*(option)*

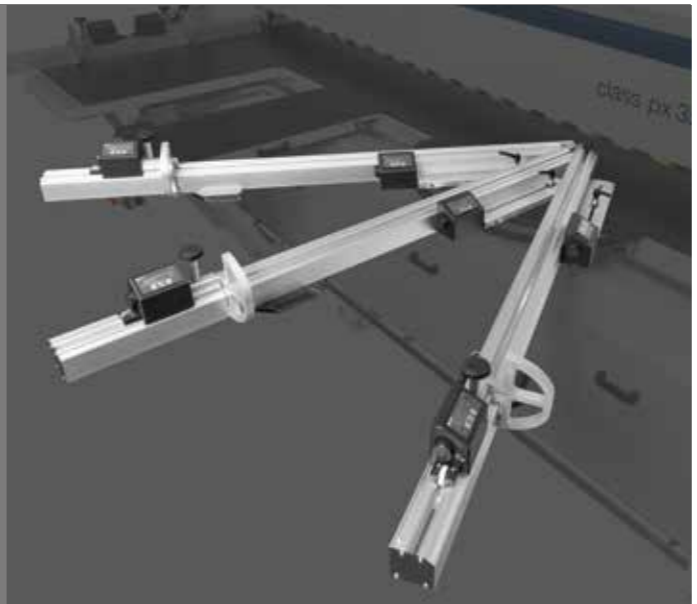

TECHNICAL DATA		class px 350i
Blades tilting		90° ÷ 46°
Max. saw blade diameter	mm	350
Max. saw blade projection from the table at 90°/45°	mm	105/72
Max. saw blade rotating speed	rpm	4000
Squaring stroke	mm	2600 ÷ 3800
Cutting width on rear fence	mm	1300
Max. telescopic fence extension	mm	2500
Max. feed speed of blade carriage	m/min	40
other technical features		
"SCM Thundercut" Optimizer/Sequencer App		S
Three-phase motor 5,5 kW (7,5 hp) 50 Hz - 6,6 kW (8 hp) 60 Hz		S
Three-phase motor 7 kW (9 hp) 50 Hz - 7 kW (9 hp) 60 Hz		O
Exhaus hoods diameter	mm	1 x 120 ; 2 x 100

automatic  
multiblade  
rip saw  
class m 3



		class m 3
Max. saw blade diameter	mm	350
Saw blade sleeve diameter (blade bore)	mm	70
Max. width of blades pack	mm	300
Min. work-piece length	mm	390
Continuously adjustable feed belt speed	m/min	6 ÷ 48
Three-phase motor power starting from	kW/Hz	18,5 (22) / 50 (60)

Find the complete technical specification at page 29



**Barriers**  
reliability and safety



**Feed Belt**  
accuracy and efficiency



**Saw Blade Shaft Sleeve**  
rapidity and effectiveness

Practical, accurate,  
reliable and above all safe.

# class m 3 operating groups and main devices



reliability and safety  
**Anti-kickback finger barriers**  
The SCM multiblade rip saw is equipped with 4 anti-kickback finger barriers: three top and one bottom and a chip deflector screen between the three top barriers.



## rapidity and effectiveness

### Saw blade shaft sleeve

It can be quickly fitted into spindle and easily locked with a special key. The conical coupling of the saw blade shaft sleeve with the base of spindle ensures longer blade life and higher output.



### Laser

Laser beam cutting line reference. Some typical uses:  
- extraction of irregular planks, without using fences  
- selection of clear parts of planks with knots and fissures  
(option)

# class m 3 technical data

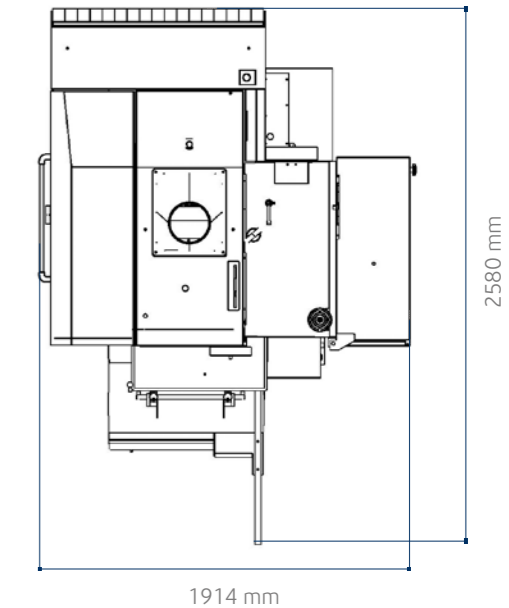

- ☐ Standard
- Option

TECHNICAL DATA		class m 3
Max. saw blade diameter	mm	350
Min. saw blade diameter	mm	200
Saw blade sleeve diameter (blade bore)	mm	70
Keys dimensions on the saw blade sleeve	mm	20 x 5
Blader rotation speed	rpm	4200
Max. width of blades pack	mm	300
Feed belt width	mm	300
Min. work-piece length	mm	390
Worktable dimensions	mm	1530 x 950
Worktable height from the floor	mm	750
Distance between base and first right blade	mm	200
Continuously adjustable feed belt speed	m/min	6 ÷ 48
<b>other technical features</b>		
Three-phase motor 18,5 kW (25 hp) 50 Hz - 22 kW (30 hp) 60 Hz		S
Three-phase motor 25 kW (30 hp) 50 Hz - 30 kW (42 hp) 60 Hz		O
Three-phase motor 37 kW (50 hp) 50 Hz - 44 kW (60 hp) 60 Hz		O
Feed belt motor power at 50 Hz (at 60 Hz)	hp	1,5 ÷ 2 (1,8 ÷ 2,4)
Exhaust hoods diameter:		
- at the blades	mm	200
- at the feed belt	mm	120



## accuracy and efficiency

### Feed belt

The machine has an extremely substantial feed belt which is directly driven through its robust belt links. Unwanted movement of saw blade shaft sleeve is prevented by the aggressive surface of the feed belt and the 4 pressure rollers (2 in front and 2 behind the blades). These advanced features ensure maximum straightening and excellent cutting quality, minimizing the quantity of stock removal in successive machining.



## practical and easy to use

### Set-up

Setting up operations can be carried out rapidly: the adjustment of spindle, pressure rollers and feed speed is carried out by hand wheels according to graduated scale and direct reading. The infeed fence is fitted with selflocking lever which can be operated single-handed. The centralized control panel is equipped with ammeter to enable operator to obtain maximum output without motor stress.

surface planers  
class f 520  
class f 410



thicknessing planers  
class s 630  
class s 520



		class f 520	class f 410	class s 630	class s 520
Working width	mm	520	410	630	520
Cutterblock diameter/standard knives	mm/n.	120/4	120/4	120/4	120/4
Total worktable length	mm	2750	2610	-	-
Max. stock removal	mm	8	8	8	8
Min. ÷ max. working height on thicknesser		-	-	3,5 ÷ 300	3,5 ÷ 300
Three-phase motors power starting from	kW/Hz	5 (6) / 50 (60)	5 (6) / 50 (60)	7 (8) / 50 (60)	7 (8) / 50 (60)

Find the complete technical specification at page 36

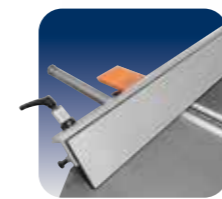

Surface Fence  
high rigidity

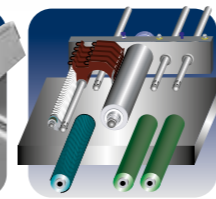

Interchangeable  
Rollers  
for every  
requirement

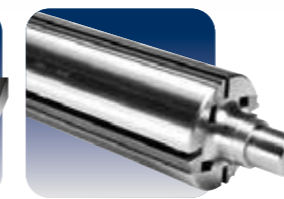

SCM Cutterblock  
simple and rapid

Easy to use and precise, stylish with practical design, a wider range of applications.

# planers operating groups

## high rigidity Surface fence

High rigid fence with a smooth movement thanks to the **central locking on round bar**. The graduated scale facilitates the operator in positioning the guide to the required tilting.

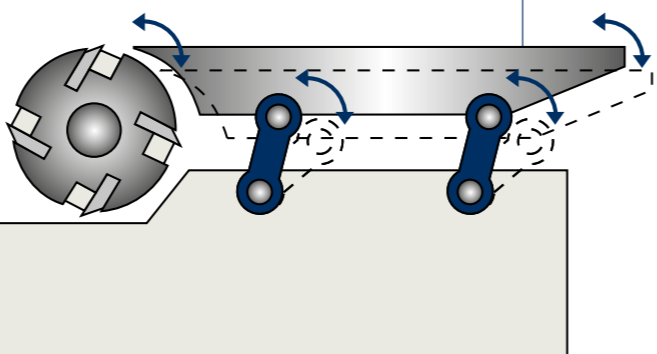
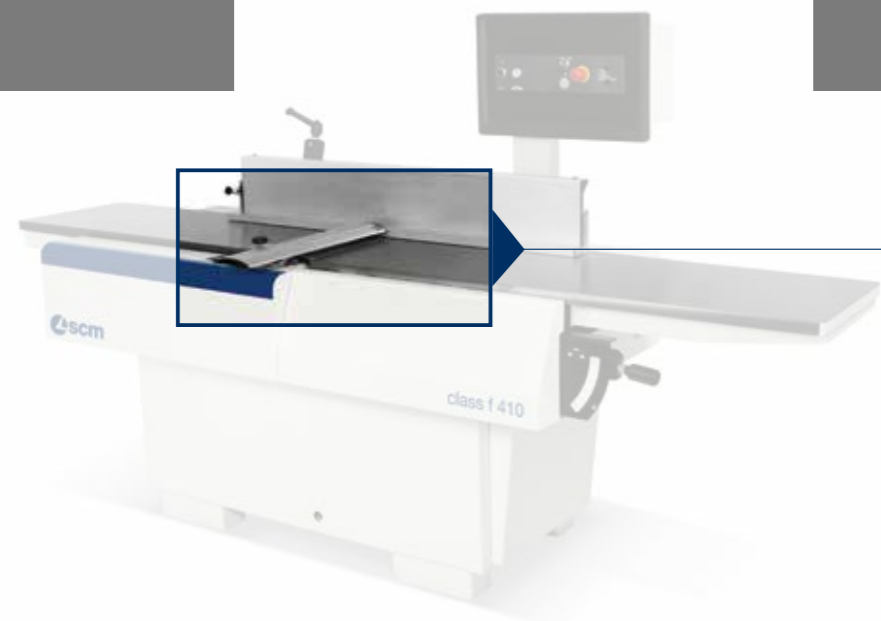

constant precision over time  
**Feeding on connecting rods**  
Very accurate machining with the movement of the infeed table by means of a parallelogram **kinetic mechanism which always gives the same distance between the cutterblock and the table**. The system operating directly on the connecting rods avoids any exertion to the table assuring constant planarity over time.

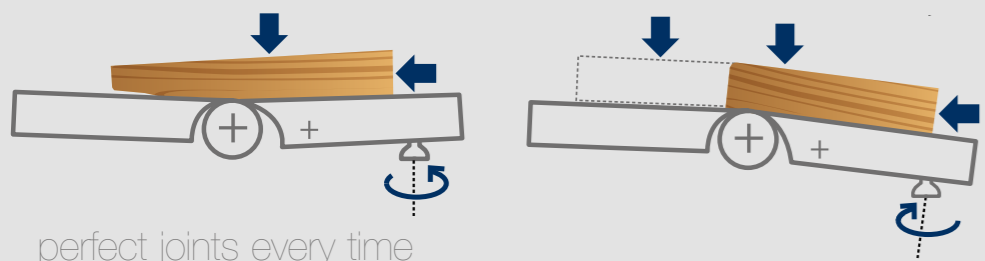

perfect joints every time  
**Concave-convex function**  
The available settings allow **perfect bonding** of the components giving excellent coupling and eliminating any joint line.

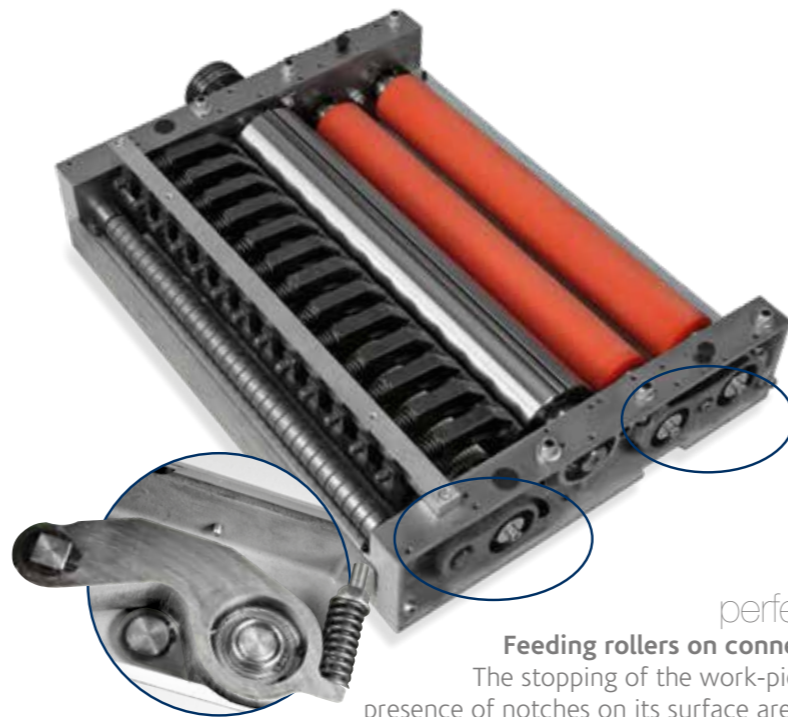

perfect finish  
**Feeding rollers on connecting rods**  
The stopping of the work-piece and the presence of notches on its surface are eliminated due to the movement system on all three rollers, that allows their vertical displacement by rotation and the **best linear feeding**. Perfect surfaces and high feeding performance with the standard rubber rollers.

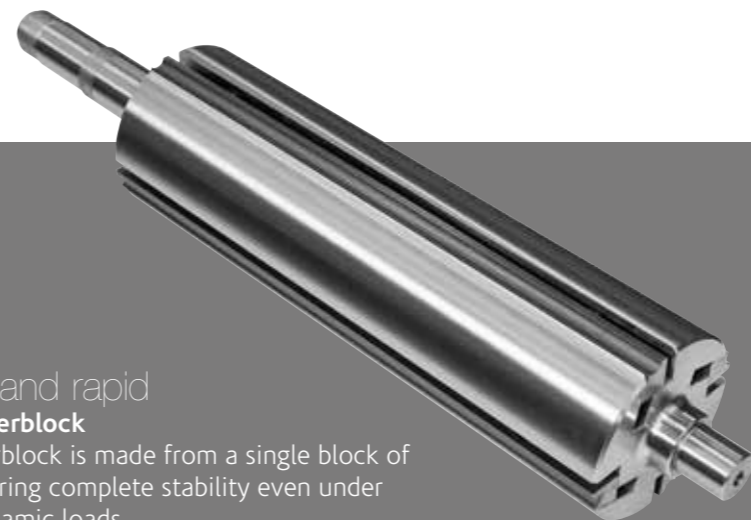

simple and rapid  
**SCM cutterblock**  
The cutterblock is made from a single block of steel ensuring complete stability even under heavy dynamic loads.

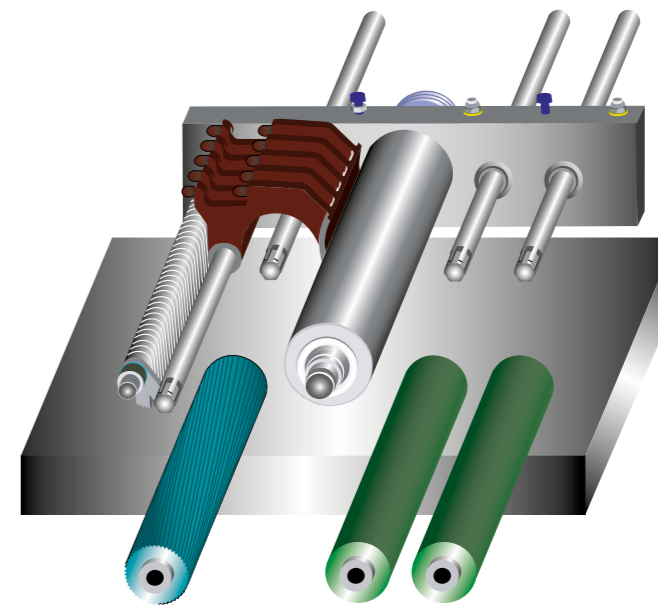

solutions for every requirement  
**Interchangeable rollers**  
**Perfect finish obtained by quick and easy changeover of the rollers** that allows the operator to configure the machine drive function in case of special requirements, such as a minimum removal of fine wood and/or batches where multiple pieces of different thicknesses are processed.

Powered worktable lifting with micrometric adjustment and digital readout.

Feed speed controlled by inverter from control panel and dedicated warning light to indicate to higher speed.

The 4 screws with a large diameter combined with the 2 side linear guides ensure worktable stability. The integrated protections guarantee high precision and reliability over time.

Pneumatic load adjustment on the rollers for the best finish and effectiveness of the feeding of any material and in any working condition.  
*(option)*



# planers main optional devices

**"Xylent" spiralknife cutterblock**  
The 3 spiralknives give an exceptional finish. **Reduced noise** during machining provides a more comfortable working environment. It also improves the dust extraction due to the **production of very small chips**. Each cutter has 4 tips which can be rotated into the cutting position when worn. Therefore, increasing the production life of the cutter block before knives require replacement.



### Maintenance case for "Xylent" spiralknife cutterblock

It includes:  
- 1 cleaning/degreasing liquid bottle for the resins cleaning  
- 1 set dynamometric key - 2 bit Torx  
- 10 inserts - 5 screws - 1 brass bristle brush to clean the spindle with mounted in inserts - 1 steel bristle brush to clean the inserts housings



### Thickening table extension to be used in infeed or outfeed

It can be installed on the worktable end side.

### Outfeed rollers in sandblasted steel

For a perfect post-processing finish.



### Special rollers

The **sectioned steel roller (a)** and the **dual-density rubber roller (b)** allow the simultaneous processing of different thicknesses giving great results even with minimum removal. With the dual-density rubber roller, the edges are not damaged even when the work-pieces are not perfectly aligned. Suitable also for upgraded woods and/or thin thicknesses.



### Additional overturning fence

Integrated in the surface fence, it ensures perfect operator safety when machining small dimensioned work-pieces.



### "Tersa" monoblock cutterblock

The cutterblock is made from a single block of steel ensuring complete stability even under heavy dynamic loads. Automatic knives clamping by means of the centrifugal force ensures safe and precise machining. The system, without fixing screws, makes knives substitution extremely fast.



### Outfeed extension for the thickening table

A single operator can easily move very long panels or introduce a second one without going to the outside to stop the first one.

### Thickening table with idle rollers

It enables the feeding of moist and/or resinous wood. Particularly suitable for heavy duty woodworking operations and with rough work-pieces.

### "Smart Lifter" integrated protection

The protection system, **developed by SCM**, is perfectly integrated into the machine base for **maximum protection** while excluding any hindrance or obstruction in the work. The protection with automatic vertical, horizontal and tilted movements **provides complete coverage of the tool** before, during and after machining.

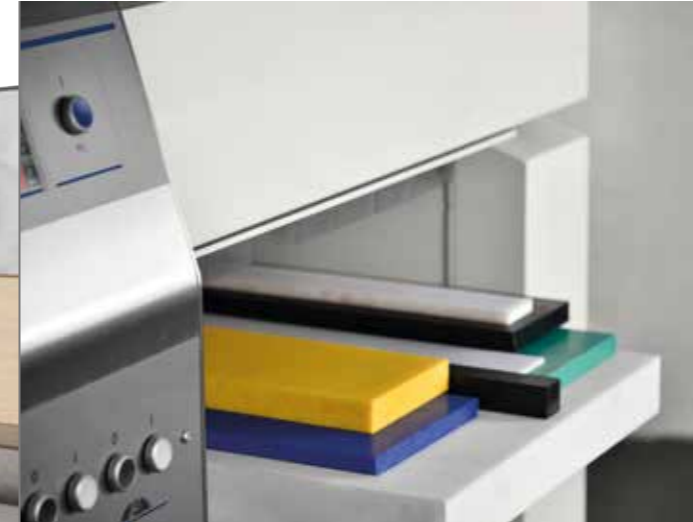

### Advanced materials machining

PVC and other plastic materials. Nylon, polycarbonate and other synthetic materials.

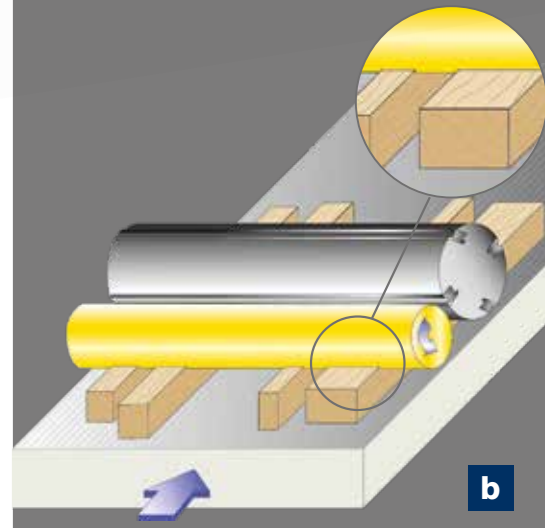

# planers technical data

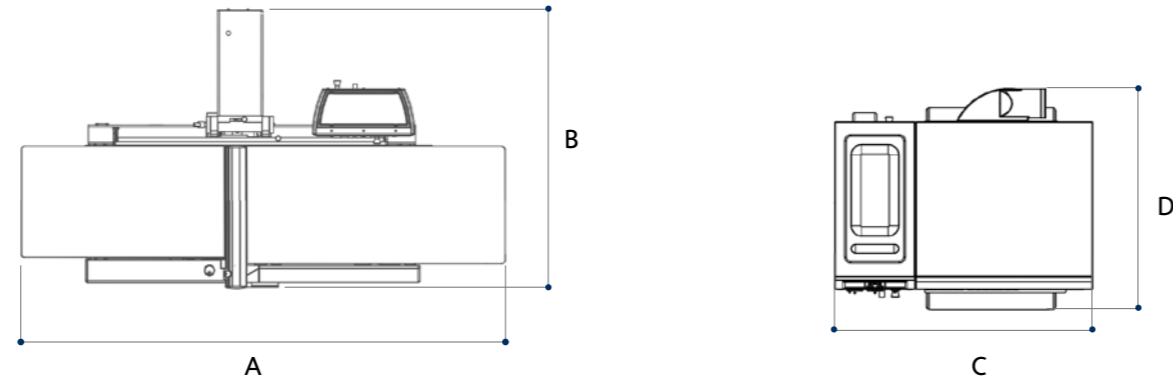

S Standard  
O Option

TECHNICAL DATA		class f 520	class f 410	class s 630	class s 520
Working width	mm	520	410	630	520
Cutterblock diameter/standard knives	mm/n.	120/4	120/4	120/4	120/4
Standard knives dimensions	mm	35 x 3 x 520	35 x 3 x 410	35 x 3 x 640	35 x 3 x 520
Max. stock removal	mm	8	8	8	8
Total worktable length	mm	2750	2610	-	-
Thicknessing table dimensions	mm	-	-	640 x 1000	530 x 900
Feed speed on thickener	m/min	-	-	4 ÷ 20	4 ÷ 20
Min. ÷ max. working height on thickener	mm	-	-	3,5 ÷ 300	3,5 ÷ 300
<b>other technical features</b>					
Three-phase motors 5 kW (6,6 hp) 50 Hz - 6 kW (8 hp) 60 Hz		S	S	-	-
Three-phase motors 7 kW (9,5 hp) 50 Hz - 8 kW (11 hp) 60 Hz		-	-	S	S
Three-phase motor 9 kW (12 hp) 50 Hz - 11 kW (15 hp) 60 Hz		-	-	O	O
Exhaust hood diameter	mm	120	120	150	150

OVERALL DIMENSIONS		class f 520	class f 410	class s 630	class s 520
A	mm	2750	2610	-	-
B	mm	1416	1155	-	-
C	mm	-	-	1280	1130
D	mm	-	-	1095	1017

MAIN OPTIONAL DEVICES	class f 520	class f 410	class s 630	class s 520
"Tersa" monoblock cutterblock	O	O	O	O
"Xylent" spiralknife cutterblock with 3 spiralknives	O	O	O	O
Maintenance case for "Xylent" spiralknife cutterblock	O	O	O	O
Additional overturning fence for the processing of thin work-pieces	O	O	-	-
"Smart Lifter" integrated protection	O	O	-	-
Worktable with 2 idle rollers	-	-	O	O
First front roller with rubber coating in place of the grooved steel one	-	-	O	O
First front sectioned steel roller in place of the grooved one	-	-	O	O
First front dual-density rubber roller in place of the grooved steel one	-	-	O	O
Outfeed steel rollers in place of the rubber-coated ones	-	-	O	O
Pneumatic pressure adjustment on the feeding rollers	-	-	O	O
Thicknessing table extension to be used in infeed or outfeed	-	-	O	O
Outfeed extension for the thicknessing table	-	-	O	O
Machine configuration for advanced materials machining	-	-	O	-

electronically and programmable spindle moulders  
 class ti 145ep  
 class ti 120e  
 class tf 130e



		class ti 145ep	class ti 120e	class tf 130e
Spindle height CE Ø 30-35 (40-50)	mm	140 (160)	140 (180)	140 (180)
Max. diameter of the profiling tool	mm	250	250	250
Max. tool diameter retractable under worktable at 90°	mm	300	320	300
Max. diameter of tenoning tool CE Ø 30-35 (40-50)	mm	300 (300)	300 (350)	300 (300)
Three-phase motors power starting from	kW/Hz	7 (8) / 50 (60)	5 (6) / 50 (60)	7 (8) / 50 (60)

Find the complete technical specification at page 48



Spindle Moulder Unit  
sturdiness and versatility



Spindle Moulder Fence  
set-up rapidity



Electronic Control  
operating advantage



Machine Versions  
specialisation and professionalism

More quality, more performance,  
 more reliability.

manual  
 spindle moulders  
 class tf 130  
 class tf 130ps  
 class ti 120



		class tf 130	class tf 130ps	class ti 120
Spindle height CE Ø 30-35 (40-50)	mm	140 (180)	140 (180)	140 (180)
Max. diameter of the profiling tool	mm	250	250	250
Max. tool diameter retractable under worktable at 90°	mm	300	320	320
Max. diameter of tenoning tool CE Ø 30-35 (40-50)	mm	300 (350)	300 (350)	300 (350)
Three-phase motors power starting from	kW/Hz	7 (8) / 50 (60)	7 (8) / 50 (60)	5 (6) / 50 (60)

*Find the complete technical specification at page 48*



**Spindle Moulder Unit**  
 sturdiness and versatility



**Spindle Moulder Fence**  
 set-up rapidity



**Machine Versions**  
 specialisation and professionalism

Precision and reliability in unbeatable time.

# spindle moulder operating groups

easy to use  
**Adjustable spindle moulder fence**  
 A handle provides the setting-up of the infeed table, which effects the removal and it is verified by an index on a metric scale.

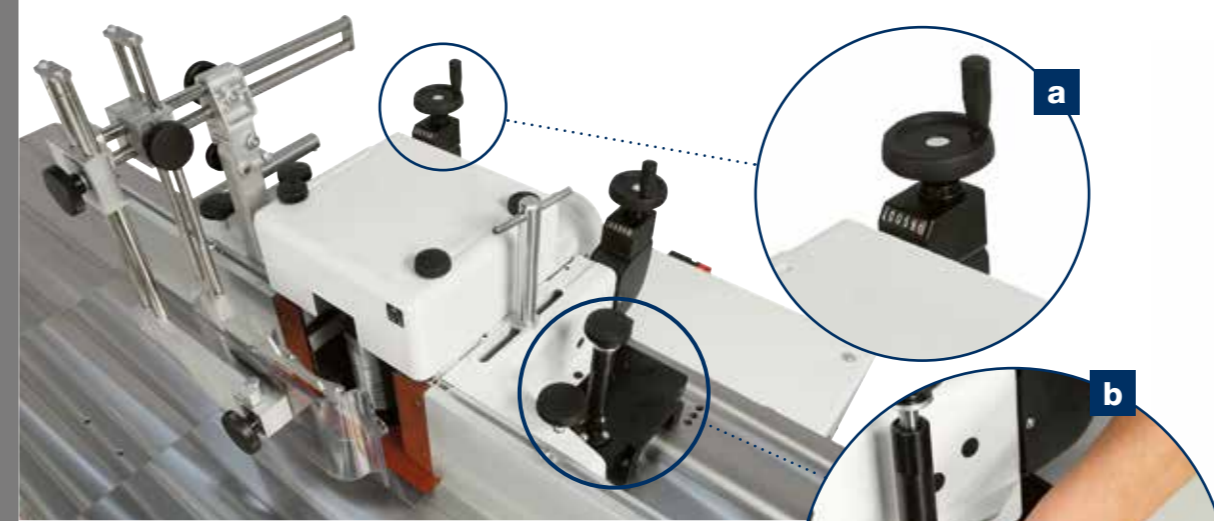
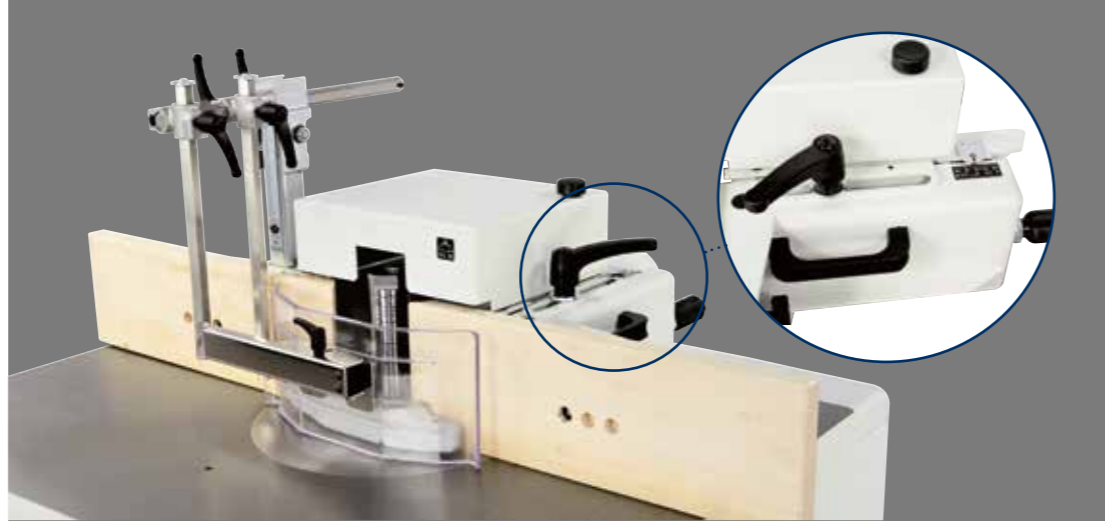

immediately in the correct position  
**"Flex" system**  
 A single, simple movement to retract and re-position instantly and accurately the position of the fence on the worktable with such precision that no other control is necessary.



sturdiness and versatility  
**Spindle moulder unit**  
 Maximum stability and rigidity in all working conditions, thanks to a **large spindle moulder column made entirely of cast iron.**  
 The spindle is surrounded by a cast iron "cup" to protect the internal mechanical components from shavings and sawdust. The 5 standard speed are ideal for any type of machining, from profiling to moulding and tenoning, with the possibility to fit large diameter tools.



the best support for the worktable  
**"Fast" sectional table**  
 Provides support for the work-piece being machined close to the tool, allowing the adjustment with mounted tools and the very best quality finish when machining narrow pieces. The extremes in machinable material eliminate the disadvantages of a possible collision with the tool.

maximum set-up speed and ease-of-use  
**Spindle moulder fence with mechanical programming**  
 No more test runs due to digital readouts (a) that ensure accuracy to a tenth of a millimetre in positioning the two worktables. The side handles (b) make it easy to remove and reposition the fence from the worktable.

automatic and removable  
**"Flex One" spindle moulder fence**  
 Automatic adjustment of the entire fence according to the tool diameter. User-friendly worktable exclusion system with precise re-positioning.

machining with tools on the spindle head carried out with the "Flex" fence  
 The spindle moulder fence can be located behind the tool allowing the performance of "head" routing using small diameter tools, typical of a router or portable electric tools; all this in compliance with CE safety regulations.



# spindle moulders machine versions



*class tf 130ps*  
**with front sliding carriage**  
Designed to manage tenoning operations very easily.



**"LL" versions with worktable side extensions**  
Ideal when machining very long work-pieces due to worktable extensions. The mobile front bar makes it easy to move large dimensioned work-pieces on the worktable, particularly for edge profiling.



**Carriage on worktable for small tenoning operations**  
Ideal for tenoning of small work-pieces for the versions without sliding carriage. Mitre cuts with angles of  $\pm 60^\circ$  on the worktable are possible. Easy fitting and removal due to the fixing system on the worktable.



**"TL PRO-10" versions**  
The manual feed carriage is a cast iron structure running on linear slideways with recirculating ball screws, guaranteeing maximum machining precision and stability.



The "PRO-10" tenoning table can be retracted easily and within a few seconds to leave the machine ready for profiling (a) or moulding (b) operations.

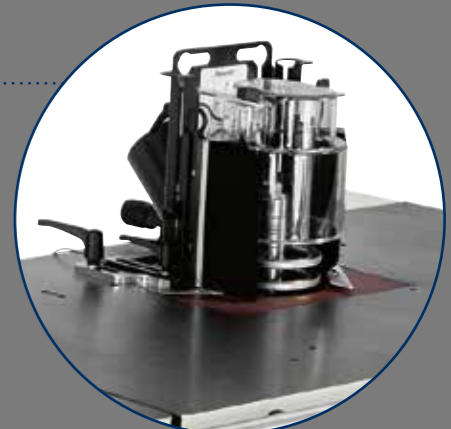

For a total safety and a higher flexibility, the machine is supplied, as standard feature, with a **special protection hood for moulding operations**.



**"TL" versions**  
Top machining precision and stability due to the manual feed carriage with castiron structure mounted on axial bearings running on slideways made from hardened and ground bar.

# spindle moulders electronic controls

Technical specification at page 49

**"Easy"**  
Maximum reliability and easy to use due to the function push buttons with the electronic control of up to 8 axes with the 7" LCD display, 16:9 format. Integrated and fast control of all dedicated functions. These features translate into immediate improvements in productivity and guarantees the capability and the full potential of the machine.



# spindle moulders main optional devices

## Feeder support device

High usable flexibility and no use of worktable space, due to the cross device on the column support of the overhead control panel. The positions are made extremely simple using handwheels with digital readout.



## "T-Set" rapid tool locking

A simple compressed air gun allows the tools locking and unlocking when the interchangeable spindle is present.

## "Ready"

The programming of the work becomes simple and effective with the electronic control with a 4" LCD colour screen. Working mode: manual, semi-automatic and automatic with a memory capacity of up to 99 programs.

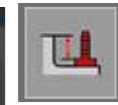
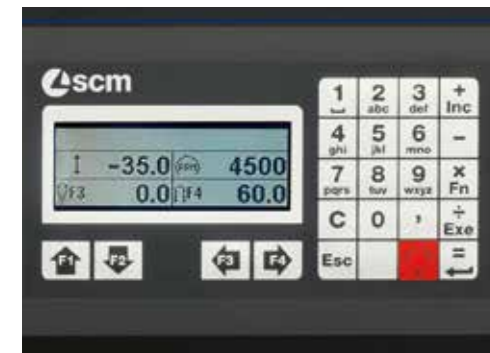

Tool-hoder shaft lifting



Adjustment of the entire profiling fence



Tool-hoder shaft tilting



Tool-hoder shaft speed readout

For the most recurring machining jobs it is possible to set the dimensions of the required profile and select the tool to be used. The controls will create the dedicated program to carry out the require machining operations.

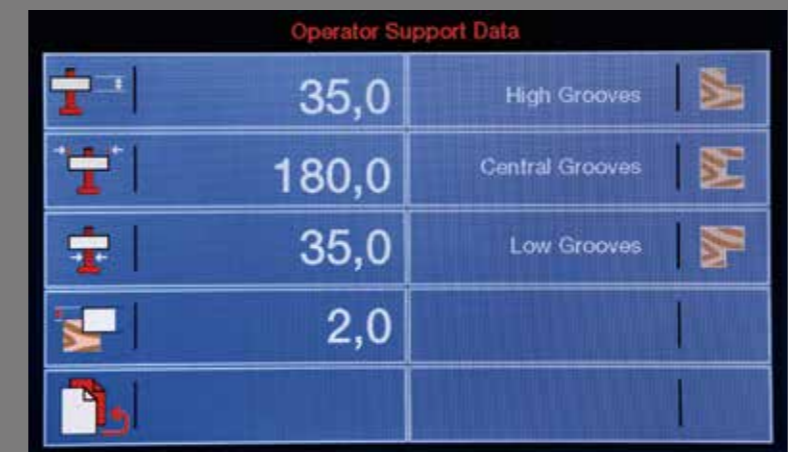

Powered operating unit movement with digital readouts. Maximum precision and ease-of-use.

"Easy" control can easily manage the inverter for the adjustment of spindle rotation speed. (option)



## Advanced materials machining

PVC and other plastic materials. Nylon, polycarbonate and other synthetic materials.

# spindle moulder technical data

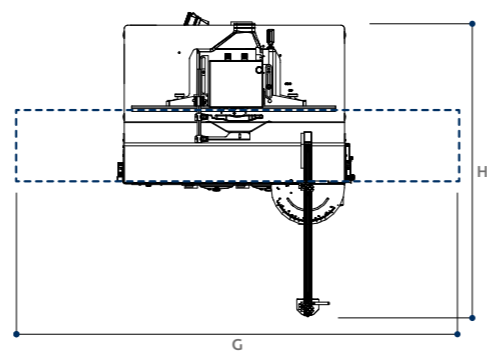
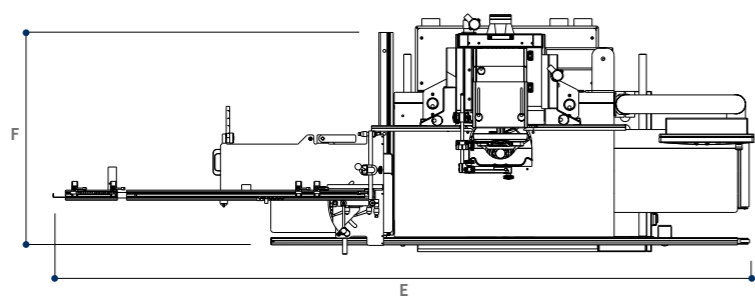
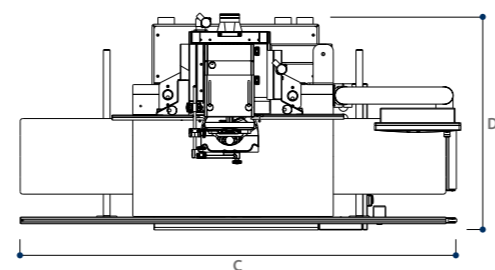
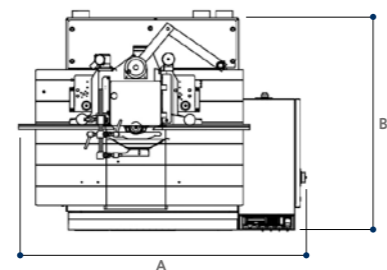

S Standard  
O Option

TECHNICAL DATA		class ti 145ep	class ti 120e	class tf 130e	class tf 130	class tf 130ps	class ti 120
Worktable dimensions	mm	1200 x 780	1200 x 810	1200 x 730	1200 x 730	1080 x 760	1200 x 810
Spindle tilting		-45,5° ÷ +45,5°	-45° ÷ +45°	-	-	-	-45° ÷ +45°
Spindle height CE Ø 30-35 (40-50)	mm	140 (160)	140 (180)	140 (180)	140 (180)	140 (180)	140 (180)
Spindle speed (at 50 Hz)	rpm	3000/4500/6000/ 7000/10.000	3000/4500/6000/ 7000/10.000	3000/4500/6000/ 7000/10.000	3000/4500/6000/ 7000/10.000	3000/4500/6000/ 7000/10.000	3000/4500/6000/ 7000/10.000
Max. diameter of the profiling tool	mm	250	250	250	250	250	250
Max. tool diameter retractable under worktable at 90°	mm	300	320	300	300	320	320
Max. diameter of tenoning tool CE Ø 30-35 (40-50)	mm	300 (300)	300 (350)	300 (300)	300 (350)	300 (350)	300 (350)
<b>other technical features</b>							
Three-phase motors 5 kW (6,6 hp) 50 Hz - 6 kW (8 hp) 60 Hz		-	S	-	-	-	S
Three-phase motors 7 kW (9,5 hp) 50 Hz - 8 kW (11 hp) 60 Hz		S	O	S	S	S	O
Three-phase motors 9 kW (12 hp) 50 Hz - 11 kW (15 hp) 60 Hz		O	O	O	O	-	O
Exhaust hood diameter:							
- at the base	mm	100	2 x 80	120	120	120	2 x 80
- on the spindle moulder fence	mm	120	120	120	120	120	120

OVERALL DIMENSIONS		class ti 145ep	class ti 120e	class tf 130e	class tf 130	class tf 130ps	class ti 120
A	mm	1655	1194	1324	1324	-	1194
B	mm	1265	1280	1010	1010	-	1280
C	mm	2600	2600	2600	2600	-	2600
D min.	mm	1265	1300	1340	1340	-	1300
D max.	mm	1575	1710	1650	1650	-	1710
E	mm	3780	3520	3551	3551	-	3197
F min.	mm	1375	1300	1340	1340	-	1300
F max.	mm	1685	1710	1650	1650	-	1710
G	mm	-	-	-	-	2080	-
H	mm	-	-	-	-	2740	-

MAIN OPTIONAL DEVICES	class ti 145ep	class ti 120e	class tf 130e	class tf 130	class tf 130ps	class ti 120
"Ready" version	S	-	-	-	-	-
"Easy" version	O	-	-	-	-	-
class tf 130ps with front sliding carriage	-	-	-	-	S	-
Mobile control panel	O	-	O	O	-	-
Powered operating unit movement with digital readouts	-	S	S	-	-	-
"Flex" spindle moulder fence	O	O	O	O	O	-
"Flex One" spindle moulder fence	O	-	-	-	-	-
Inverter for the rotation speed adjustment from 900 to 10.000 rpm	O	-	-	-	-	-
Feeder support device with manual vertical and horizontal movements	O	-	O	O	-	-
Spindle moulder fence with mechanical programming	S	S	S	O	O	O
Aluminium tabled instead of the wooden ones for profiling fence	O	O	O	O	O	O
Interchangeable spindle	S	O	O	O	O	O
Spindle for router bits	O	O	O	O	O	O
"T-Set" rapid tool locking	O	-	O	O	O	-
"Fast" sectional table with manual adjustment	S	-	S	O	-	-
"LL" version with 2 cast-iron profiling extensions	O	O	O	O	-	O
"TL" version for tenoning and profiling	O	O	O	O	-	O
"TL PRO-10" version for tenoning and profiling	O	-	O	O	-	-
Tenoning table and tenoning hood	-	-	-	-	S	-
Carriage on the fixed table for small tenoning operations	O	O	O	O	-	O
Machine configuration for advanced materials machining	O	-	O	O	O	-

# PROMPT AND EXPERT TECHNICAL SUPPORT THROUGH A NETWORK OF 1000 TECHNICIANS AND AN INVENTORY OF 36,000 SPARE PARTS.

HIGHLY SPECIALISED TECHNICIANS, EFFICIENT MANAGEMENT AND 6 SPARE PARTS BRANCHES AROUND THE WORLD GUARANTEE A CLOSE, SAFE AND EFFECTIVE TECHNICAL SUPPORT.

## SERVICE

SCM provides a service that goes beyond the purchase, to guarantee the long term performance of your technological production system and peace of mind for your business.

### A COMPLETE RANGE OF AFTER-SALES SERVICES

- installation and start-up of machines, cells, lines and systems
- tailored training programs
- telephone support to reduce times and costs when machines are not working
- preventive maintenance programs to guarantee long term performance
- complete renovation of machines and plants to renew the added value of the investments
- custom upgrading to update machines and plants and meet new production requirements



## SPARE PARTS

SCM Group can count on 140 spare parts professionals worldwide to meet any request with real time shipments.



### 36,000 SPARE PARTS

Our spare parts inventory, with a value of 12 million euros, covers every single machine



### SPARE PARTS GUARANTEED

We guarantee also hard to find parts, with 3,5 million euros invested in "critical" spare parts.



### IMMEDIATE AVAILABILITY

Over 90% of orders received are carried out the same day thanks to the huge inventory available.



### 6 BRANCHES AROUND THE WORLD

The spare parts service can count on worldwide support (Rimini, Singapore, Shenzhen, Moscow, Atlanta, São Bento do Sul)



### 500 SHIPMENTS A DAY



# THE STRONGEST WOOD TECHNOLOGIES ARE IN OUR DNA

## SCM. A HERITAGE OF SKILLS IN A UNIQUE BRAND

Over 65 years of success gives SCM the centre stage in woodworking technology. This heritage results from bringing together the best know-how in machining and systems for wood-based manufacturing. SCM is present all over the world, brought to you by the widest distribution network in the industry.

- 65+ years history
- 3 main production sites in Italy
- 300.000 square metres of production space
- 20.000 machines manufactured per year
- 90% export
- 20 foreign branches
- 400 agents and dealers
- 500 support technicians
- 500 registered patents



In SCM's DNA also strength and solidity of a great Group. The SCM Group is a world leader, manufacturing industrial equipment and components for machining the widest range of materials.

## SCM GROUP, A HIGHLY SKILLED TEAM EXPERT IN INDUSTRIAL MACHINES AND COMPONENTS

### INDUSTRIAL MACHINERY

Stand-alone machines, integrated systems and services dedicated to processing a wide range of materials.



### INDUSTRIAL COMPONENTS

Technological components for the Group's machines and systems, for those of third-parties and the machinery industry.



# dmc sd range

automatic wide belt sanders



# YOUR NEEDS, OUR SOLUTIONS



dmc sd 30



dmc sd 60



dmc sd 70



dmc sd 90

- 6  
DMC SD 30
- 8  
DMC SD 60
- 10  
DMC SD 70
- 12  
DMC SD 90

## SOLID



**Sturdy** main frame for high production capabilities.

Up to 18,5 kW power for **high stock removal calibrating**.

## MADE IN ITALY



**100% made in Italy**  
**Over 60 years' experience** in innovating and manufacturing woodworking machines guarantees **top reliability and quality standards**.

## RELIABLE



Technical features and design characteristics ensure a correct functioning and a **long-lasting reliability**.

## FLEXIBLE



**Wide availability of technological devices** which makes the **sd range flexible and versatile** for every production process.

## LEAN



The design, the concept and the general principles for the machine project are inspired by **lean production** to grant the customer a maximized result.

42  
Machine controls

43  
Technical data

# TECHNOLOGICAL FEATURES

TECHNOLOGICAL ADVANTAGES



*Belt oscillation controlled by an electronic photocell for longer life span of the belt.*

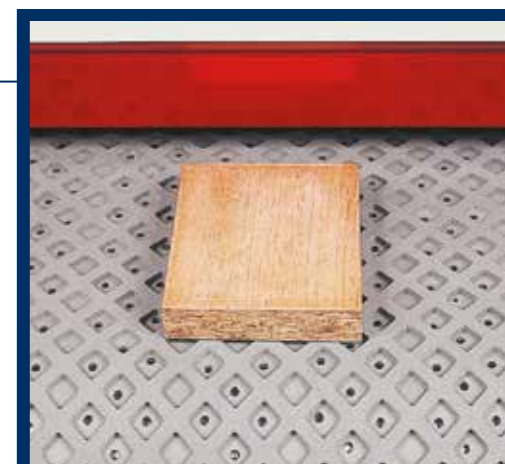

*Natural rubber vacuum table with diamond-shaped belt: the best piece traction and the maximum stability.*

### Available versions

*It is available with 950 and 1100 mm working widths, it is possible to accommodate 1 to 2 operating units to ensure a high flexibility level.*



CS



RCS



*Sequencing Led indicator for panel introduction to ensure reduced machining costs.*

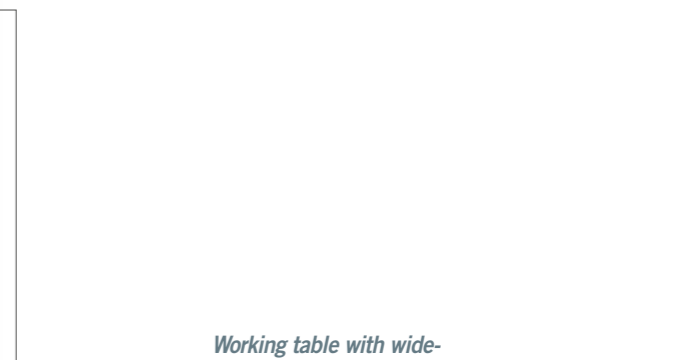

*Working table with wide-opening from 4 to 170 mm, for substantial working thickness processing.*

# TECHNOLOGICAL FEATURES

TECHNOLOGICAL ADVANTAGES

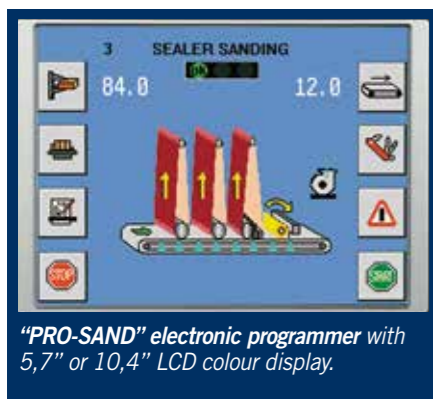

*"PRO-SAND" electronic programmer with 5,7" or 10,4" LCD colour display.*



*Automatic table positioning: the automatic detection of the work piece thickness allows precise machining at all times.*



**CS**



**RR**



**RCS**



**RRR**

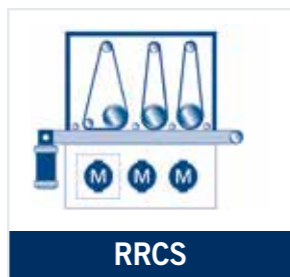

**RRCS**

*Available versions  
Five versions, one to five operating units and 1100 and 1350 mm working widths.*



*Sequencing Led indicator for panel introduction to ensure reduced machine costs.*

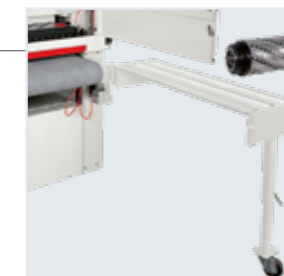

*"HPL" planer unit, maximum removal in just one single pass.*



*Buffing and structuring units on the outfeed of the working table for exclusive surface finishes.*



*Interchangeable brushing unit on the outfeed of the working table for high processing flexibility.*

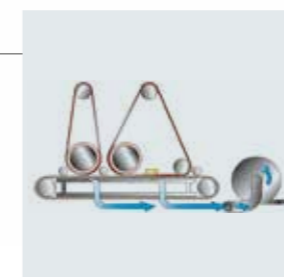

*Vacuum table no slipping of the work piece.*



*Automatic feed belt centering for a longer lifespan of the belt.*

# TECHNOLOGICAL FEATURES

TECHNOLOGICAL ADVANTAGES



Long belts: 2620 mm length for greater productivity and less downtime.



160 mm rollers diameters for heavy-duty processing.



RR



RCS

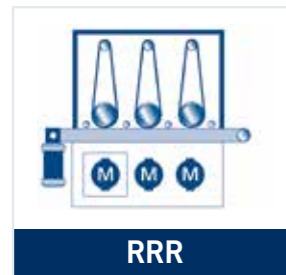

RRR

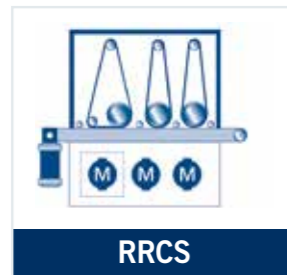

RRCS

Available versions  
Four versions, equipped with two or three operating units and 1350 mm working widths.



Belt oscillation controlled by an electronic photocell for longer lifespan of the belt.



Oscillating buffing unit and structuring unit on the outfeed of the working table for exclusive finishing.



Interchangeable brushing unit on the outfeed of the working table for high processing flexibility.

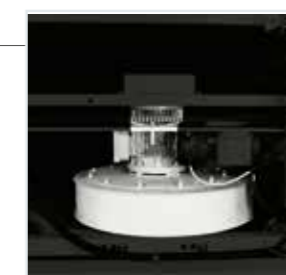

Integrated electro-fan, reduced overall dimensions and noise emissions with the fan positioned under the work table.

900 mm fixed height worktable for increased versatility (opt.)

# TECHNOLOGICAL FEATURES

TECHNOLOGICAL ADVANTAGES

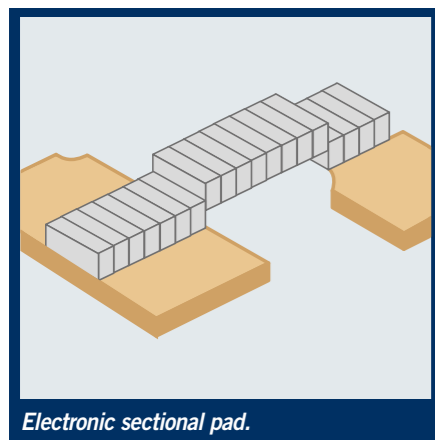

Electronic sectional pad.

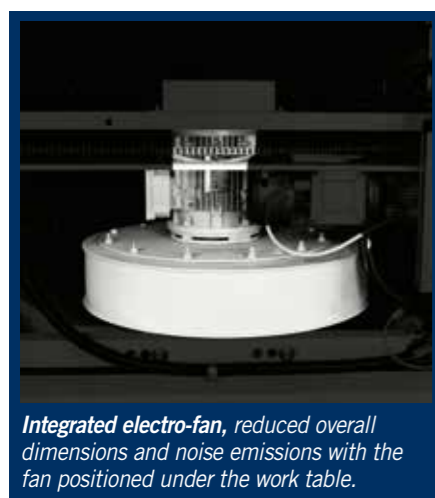

Integrated electro-fan, reduced overall dimensions and noise emissions with the fan positioned under the work table.



Superfinishing unit with 2620 mm belt length.



Natural rubber vacuum table with diamond-shaped belt: the best piece traction and the maximum stability.



Extractable internal crossbelt unit with 5000 mm belt length.

**Available versions**

It is available in 12 versions, with two or three main operating groups, in which it is possible to insert a crossbelt or a planer unit in the first position, substitute the pad unit with a superfinishing unit, and add a complete range of devices for the work table and the presser units.



RR



RT



TT



RRR



RCS



RRT



RTT



RCST



RRCS



XRCs



XRR



XRT

# AVAILABLE PRE-CONFIGURED VERSIONS FOR DIVERSIFIED MACHINING

The available versions allow to set the machine in order to realize diversified machining with the highest level of finishing. The dmc sd range is the correct choice for SME's requiring customised solutions for answering swiftly to any market requirement.

## A VERSION



On-off pneumatic selector for rollers



On-off pneumatic selector for combined unit

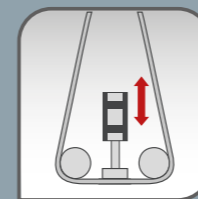

On-off pneumatic selector for pad



Electronic working thickness positioning

## B VERSION



On-off pneumatic selector for rollers



On-off pneumatic selector for combined unit

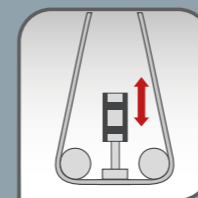

On-off pneumatic selector for pad



Electronic working thickness positioning

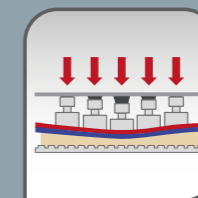

Elastic sectional pad

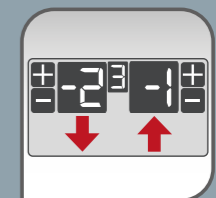

Logic 50 electronic programmer

## C VERSION



On-off pneumatic selector for rollers



On-off pneumatic selector for combined unit

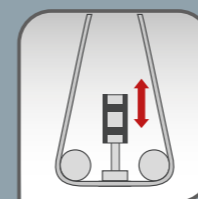

On-off pneumatic selector for pad

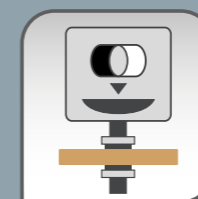

Electronic working thickness positioning

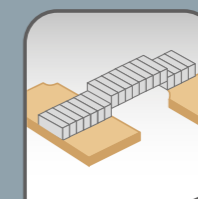

Electronic sectional pad

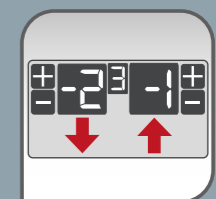

Logic 50 electronic programmer

# A VERSION

## THE IDEAL SOLUTION FOR SOLID WOOD



**ON/OFF PNEUMATIC SELECTOR ON THE ROLLER UNIT**  
It allows the roller exclusion from the sanding process while maintaining the working table position unchanged.



**ON/OFF PNEUMATIC SELECTOR FOR COMBINED UNIT**  
It allows the roller exclusion, or the sanding pad exclusion or both of them, from the sanding process while maintaining the working table position unchanged.



**EXTRACTABLE RIGID PAD**  
The rapid extraction system allows easy interchangeability of inserts for a rapid changeover from one type of machining to another. Possibility to add the semi-rigid pad when sanding veneered panels (option).



**AUTOMATIC TABLE POSITIONING**  
The automatic detection of the work piece thickness allows precise machining at all times and without the risk of operator error. The decimal setting of this system also allows setting the work depth independently of the material.

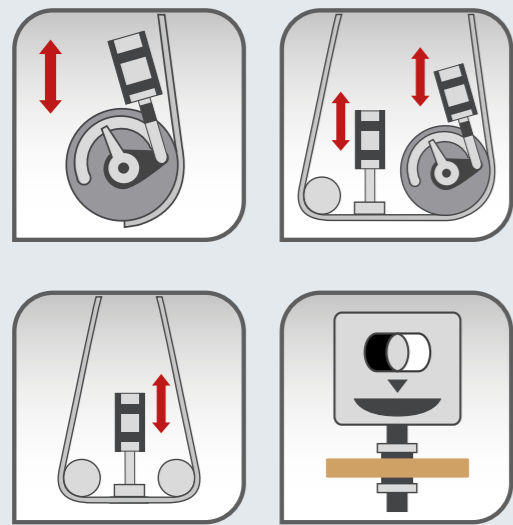

Universal calibrating and sanding of **solid wood**.

1. On-off pneumatic selector for rollers
2. On-off pneumatic selector for combined unit
3. On-off pneumatic selector for pad
4. Electronic working thickness positioning

# B VERSION

## THE IDEAL SOLUTION FOR SOLID WOOD AND VENEERED MATERIALS



### ELASTIC SECTIONAL PAD

Thanks to its capacity of adapting the irregular surfaces, it can be used for veneered panels sanding, even when they are not perfectly flat.

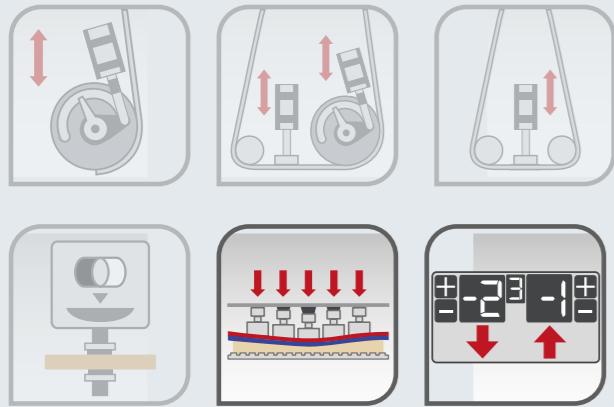

Calibrating and sanding of **solid wood and veneered material**.

1. On-off pneumatic selector for rollers
2. On-off pneumatic selector for combined unit
3. On-off pneumatic selector for pad
4. Electronic working thickness positioning
5. Elastic sectional pad
6. Logic 50 electronic programmer



### "LOGIC 50" ELECTRONIC PROGRAMMER

Easy to use.

It controls a sectional pad in addition to pads and rollers, for machines with variable feed speed.

# C VERSION

THE IDEAL SOLUTION FOR SOLID WOOD, VENEERED AND PAINTED MATERIALS



**“MESAR” ELECTRONIC SECTIONAL PAD, THE BEST FINISH WITH ANY MATERIAL**

Higher quality results due to the special shape of the sectors that allow the operator to intervene “softly” but also in an “aggressive” way, simply by varying the working pressure. The setting of the pad position and the possibility of using foils of different thicknesses increases its versatility. A line of sensors detecting the work piece profile, automatically controls the electronic pad intervention thus avoiding any possible damage when machining.

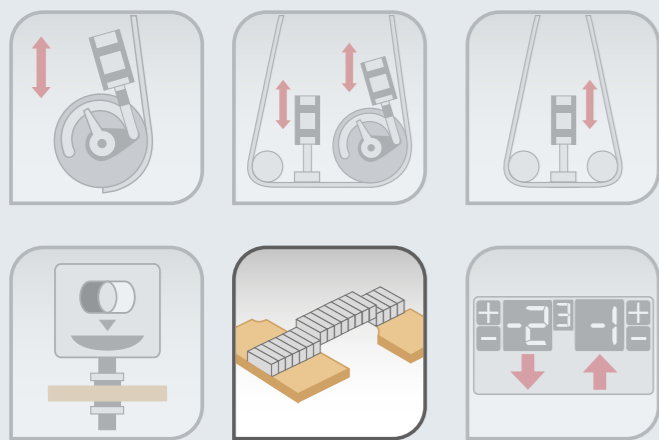

Solid wood and veneered calibrating and sanding also on honeycomb panels with irregular shapes and painted materials.

1. On-off pneumatic selector for rollers
2. On-off pneumatic selector for combined unit
3. On-off pneumatic selector for pad
4. Electronic working thickness positioning
5. Electronic sectional pad
6. Logic 50 electronic programmer

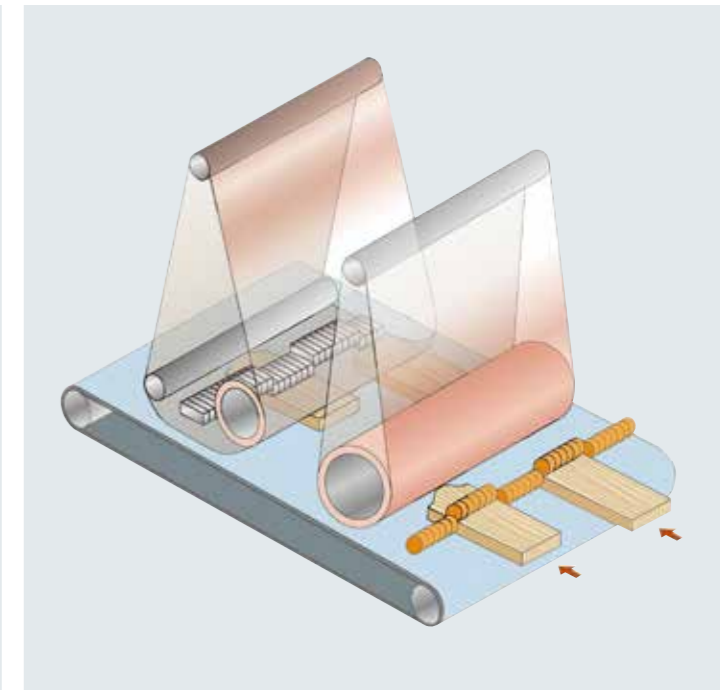
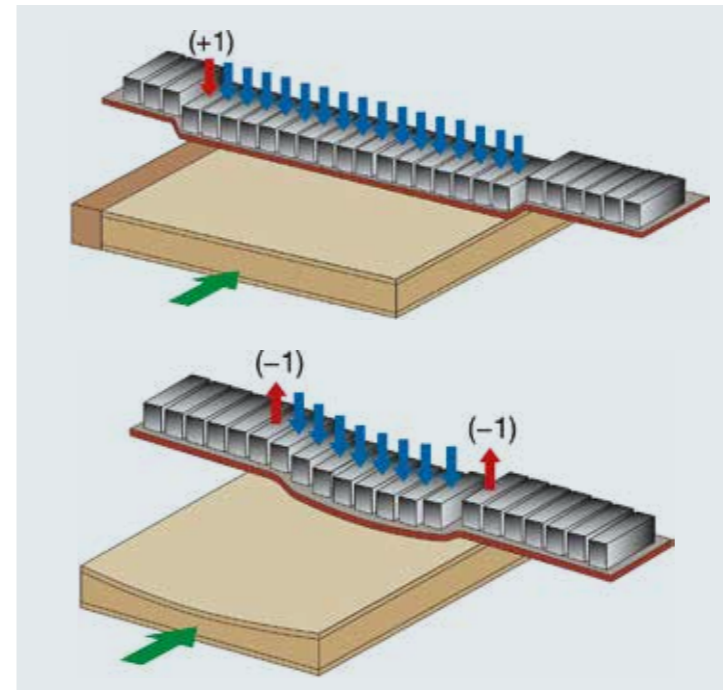

# OPERATING UNITS

## AVAILABLE VERSIONS



### CS VERSION

The CS combined unit is the secret of the dmc sd 30 and sd 60 flexibility. The possibility to use the roller and the pad either simultaneously or independently of one another provides high quality results.

sd 30 sd 60



### RR VERSION

This version is perfect for operations where heavy stock removal rates are required or where users have to machine narrow work pieces or any type of frame (windows and door frames). The large dimensioned sanding roller guarantees the very best finishing even on veneered and painted surfaces.

sd 60 sd 70 sd 90

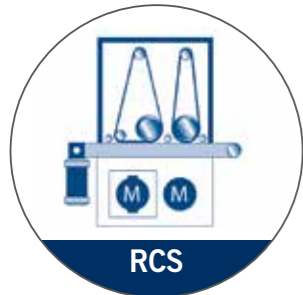

### RCS VERSION

Higher flexibility and productivity for a top quality finishing in a single passage. Ideal for all "typical" requirements of woodworking and veneering companies: from solid wood to veneered panels. The electronic sectional pad availability in models with 1100 mm working width, also enables the machining and sanding of honey-comb veneered panels.

sd 30 sd 60 sd 70 sd 90

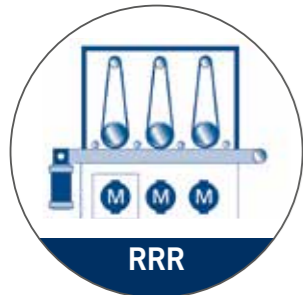

### RRR VERSION

This version is dedicated to customers specialised in calibrating and sanding of generic solid wood and doors and windows elements. The machine configuration equipped with three working units guarantees the full process in one single pass.

sd 60 sd 70 sd 90

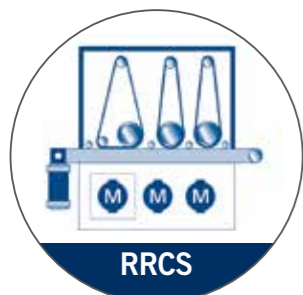

### RRCS VERSION

The 3-unit configuration ensures high flexibility and time saving and makes this machine perfect for both calibrating and sanding operations of large dimensioned panels. In the furniture sector (with veneered, lacquered and painted panels) it excels in the provision of an optimum level of finishing due to the "MESAR" electronic sectional pad.

sd 60 sd 70 sd 90

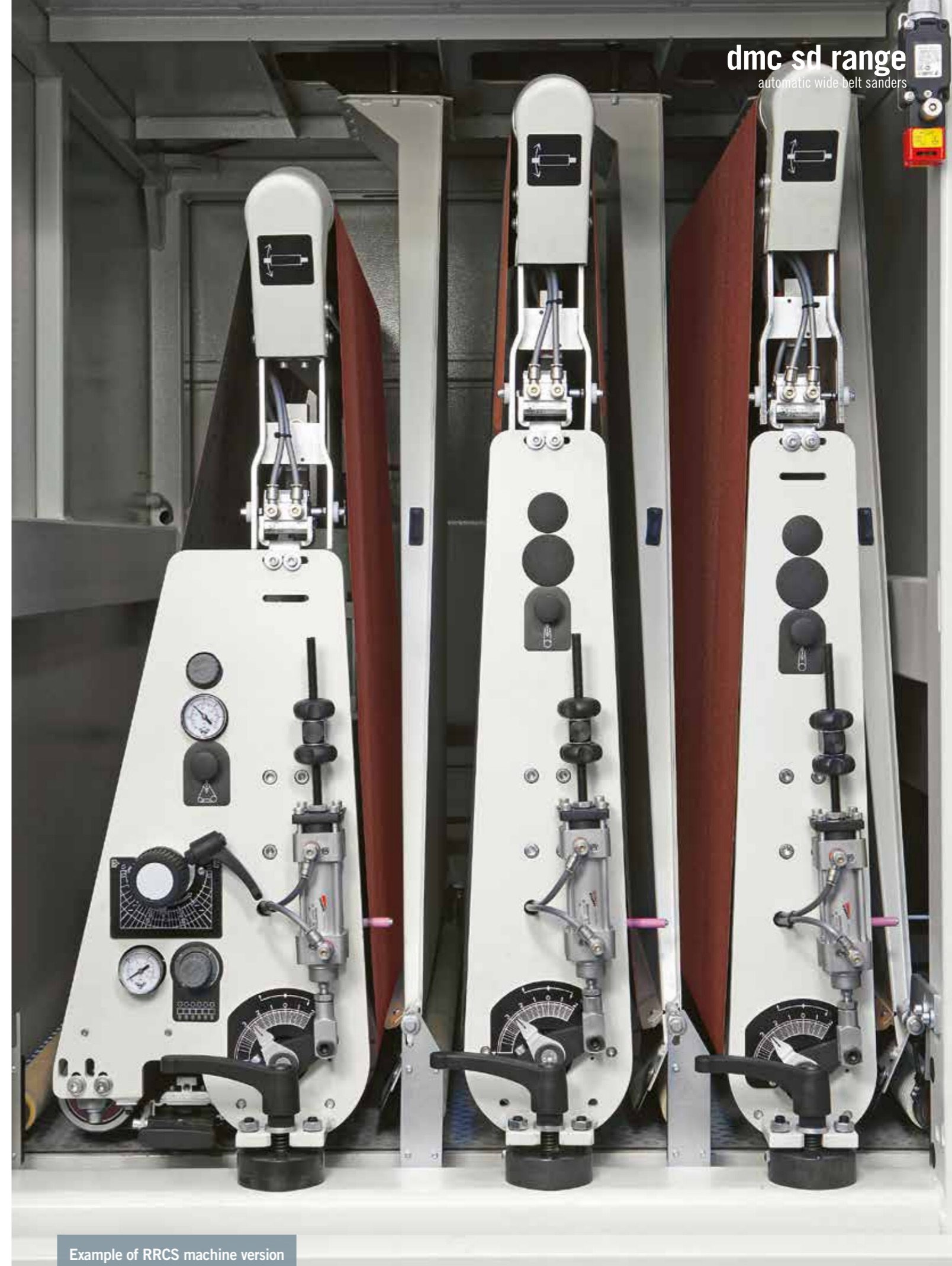

Example of RRCS machine version

# OPERATING UNITS

## AVAILABLE VERSIONS

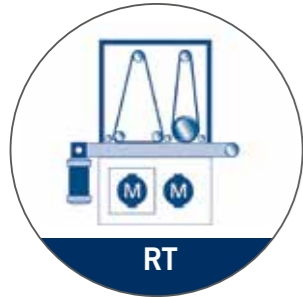

RT

### RT VERSION

It grants high flexibility and productivity as well as top finishing in one single pass due to the superfinishing unit.

Excellent for all "typical" processing of solid wood, veneered panels and the sanding of the basecoat.

sd 90

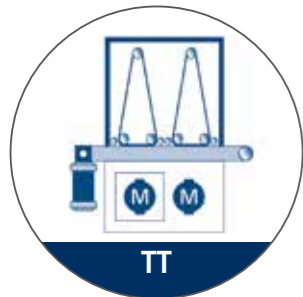

TT

### TT VERSION

For all processing of panels with basecoat that require a high level of finishing. It can be achieved with the superfinishing unit.

sd 90



RCST

### RCST VERSION

This version, available with the superfinishing unit, is perfect for both calibrating and sanding operations of large dimensioned panels. In the furniture sector (with veneered and painted panels) it excels in the provision of significant finishing.

sd 90



RRT

### RRT VERSION

For all rough, veneered and painted panels processes that need a high level of finishing. Available with the superfinishing unit.

sd 90



RTT

### RTT VERSION

This configuration is ideal for all sanding processing of painted panels that, due to the superfinishing unit, want high finishing standard.

sd 90



XRT

### XRT VERSION

For all operations on painted panels that need the precision of the electronic sectional pad and the highest finishes up to 1000 grit.

sd 90

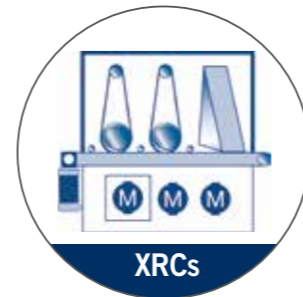

XRCs

### XRCs VERSION

For all processing that demand a pre-sanding activity and the precision of the electronic pad.

sd 90

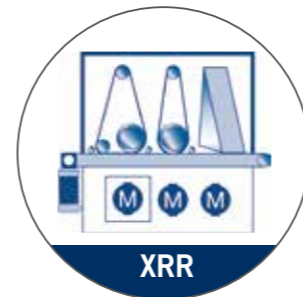

XRR

### XRR VERSION

For all processing that require pre-sanding activity. Optimal for solid wood applications.

sd 90

Example of XRT machine version



# OPERATING UNITS

## CALIBRATING/SANDING ROLLERS



Rollers are available in different diameters from 120 to 320 mm, both in grooved steel and rubber coating option for any requirement.

sd 30 sd 60 sd 70 sd 90

### RUBBER-COATED ROLLER

The wide range of hardness (from 85 to 20 sh) enables the roller to obtain excellent results from the most aggressive sanding to the most delicate operations on veneered and painted panels.

### GROOVED STEEL ROLLER

It provides the maximum precision on heavy calibrating operations, even on wood with a differentiated grain and knotted solid wood.



dmc sd range  
automatic wide belt sanders

Diameter	sd 30	sd 60	sd 70	sd 90
120 mm	•			
140 mm		•	•	
160 mm		•	•	
175 mm		•	•	•
250 mm		•	•	•
320 mm				•

# WORKING UNITS

## PLANER UNIT

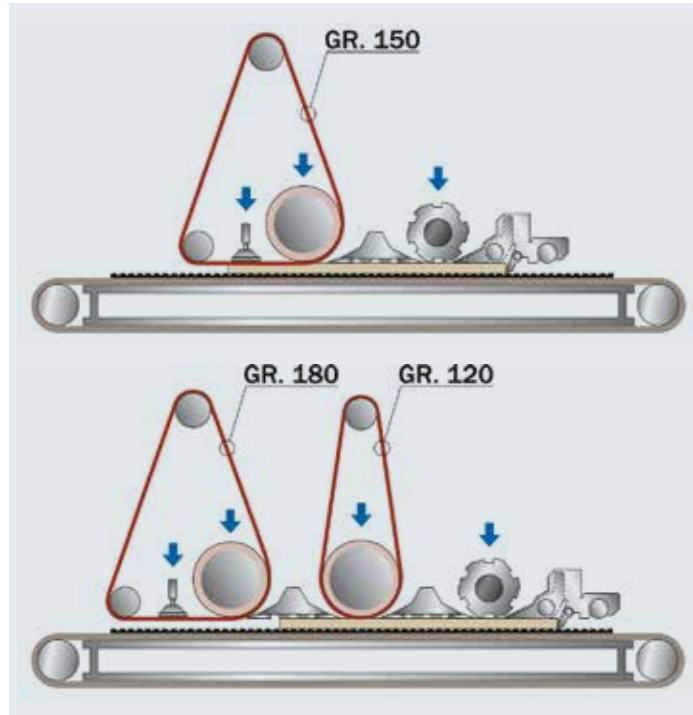

### PLANER UNIT

One single pass to perform heavy material removal with low power consumption; a degree of finish comparable to the one obtained with the use of 4 abrasive belts due to the helicoidal positioning of the knives mounted on the unit.

The easy access allowed by the exclusion of the infeed rollers simplifies maintenance operations (option). The anti-kickback fingers, the heavy sectional bar and the micro switch for too thick components set on the pressure roller, makes it absolutely safe when employing the HPL planer unit, even for an unskilled operator.

sd 60 sd 90



### "HPL" PLANER UNIT: MAXIMUM REMOVAL COUPLED WITH MAXIMUM SAVINGS

After planing, the surface of the panel needs only a slight degree of finishing. This can be done with a 150 grit sanding belt using a single operating unit or a 180 grit sanding belt using two operating units.

sd 60 sd 90



# OPERATING UNIT

## CROSSBELT UNIT

### CROSSBELT UNIT: AN EXCEPTIONAL FINISH IN SYNERGY WITH THE SANDING OF ROLLER UNIT OR SUPERFINISHING UNIT

The crossbelt sanding unit can be used as a setup unit for a following sanding operation, such as adhesive paper or filler removal, or as a final unit for the sanding of painted surfaces that require a high-quality finishing (polished or opaque effects).

The high-performance of the crossbelt unit are guaranteed by the electronic sectional pad, the 5000 mm belt length and from the cleaning system for a longer lifespan of belt and finishing uniformity.

sd 90

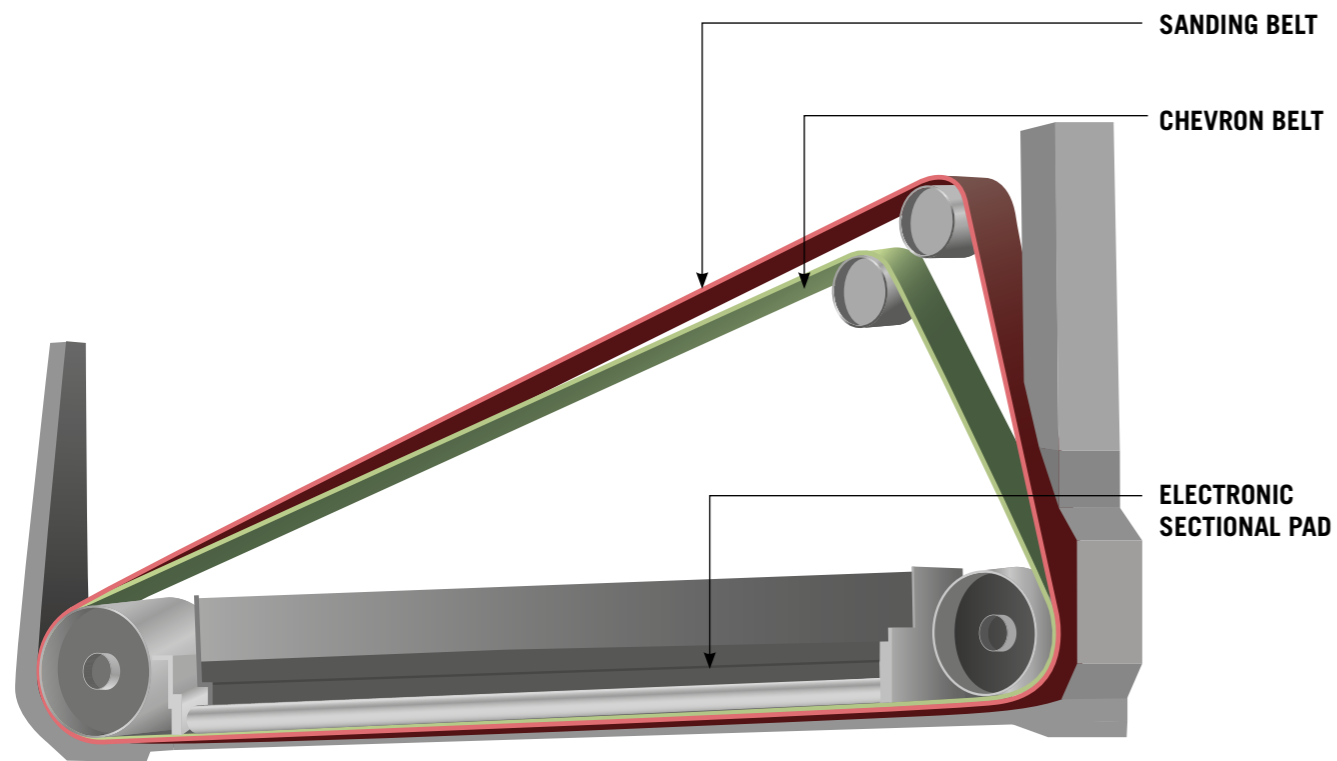

# OPERATING UNITS

## SUPERFINISHING UNIT

### SUPERFINISHING UNIT: HIGH-QUALITY PROCESSING

Uniform finish with the chevron belt which improves the cooling of the abrasive action on the work piece and the copying capacity of the "MESAR" electronic pad.

The unit is particularly suitable for the superfinishing of solid wood components, MDF panels that have been laminated, veneered or painted (opaque and polished). It is the ideal choice for all companies that require the highest finishing level on "hi-gloss" panels.

sd 90

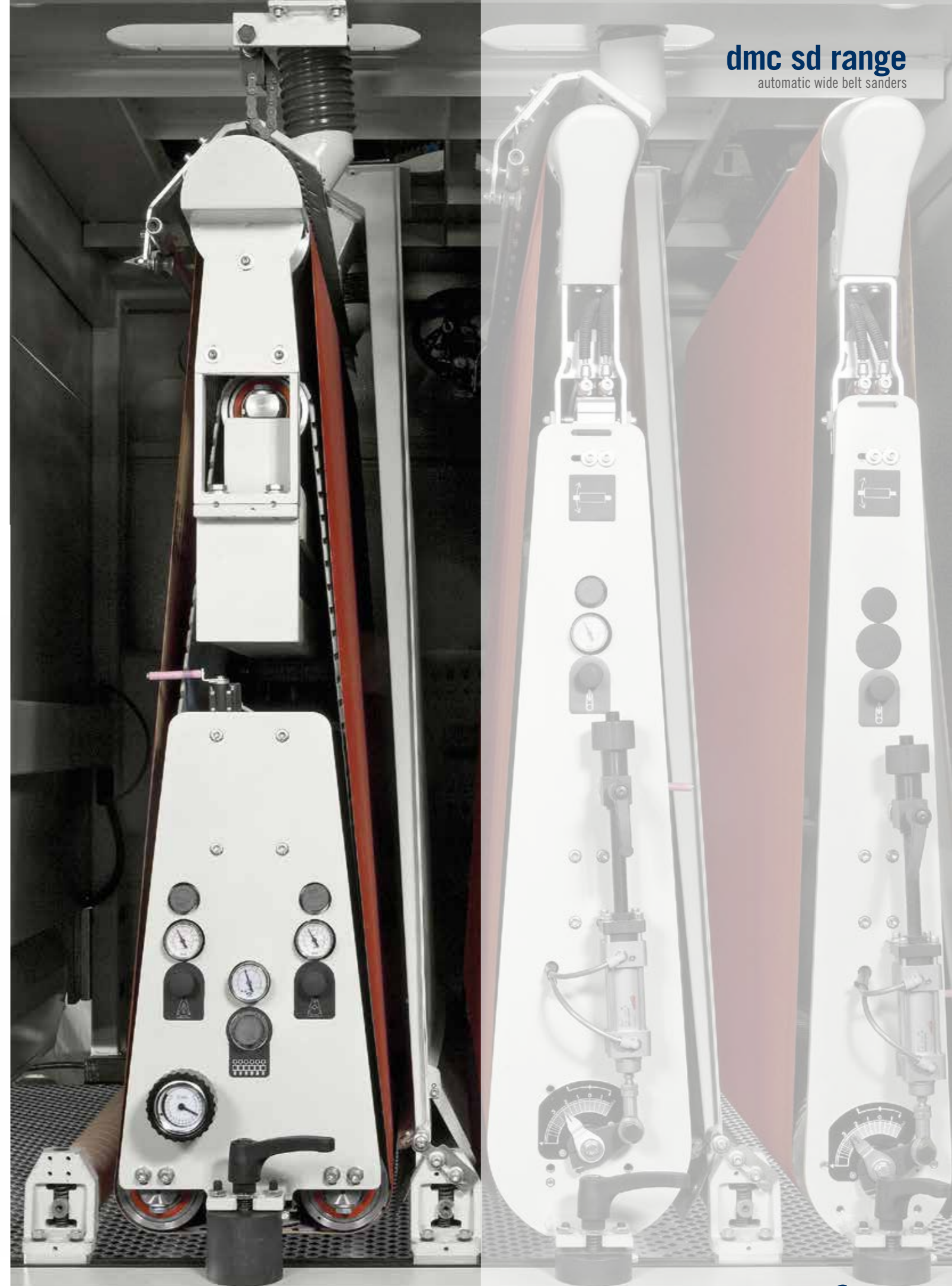

# WORKING UNITS ON THE OUTFEED



## BUFFING UNIT

It provides a perfect finish and a smooth panel surface before final painting.

sd 60 sd 70 sd 90



## STRUCTURING UNIT

It gives the panel a rustic or weathered look, particularly recommended for period furniture.

sd 60 sd 70 sd 90



# WORKING UNITS ON THE OUTFEED

## BRUSHING UNIT

The GSI interchangeable brushing unit has been designed to meet the flexibility and production versatility needs of small and medium sized manufacturers. The unit, thanks to the oscillation system and the tools diameter of 200 mm, can use: grain evidencing steel or tynex rollers, sanding rollers with abrasive strips for brushing, Scotch-Brite abrasive cloth rollers for the finish on paint, or cleaning rollers.

Tool changeover takes a maximum of five minutes for unskilled operators.

sd 60 sd 70 sd 90



# OTHER DEVICES

## FLOATING PRESSURE SHOES

The best finishing of solid wood. The particular design of the pressure shoes greatly reduces the centre-to-centre distance during sanding. This feature guarantees a higher but more uniformly distributed hold-down pressure when calibrating solid wood with high stock removal and the sanding of short, narrow and uneven components.

sd 60 sd 70 sd 90

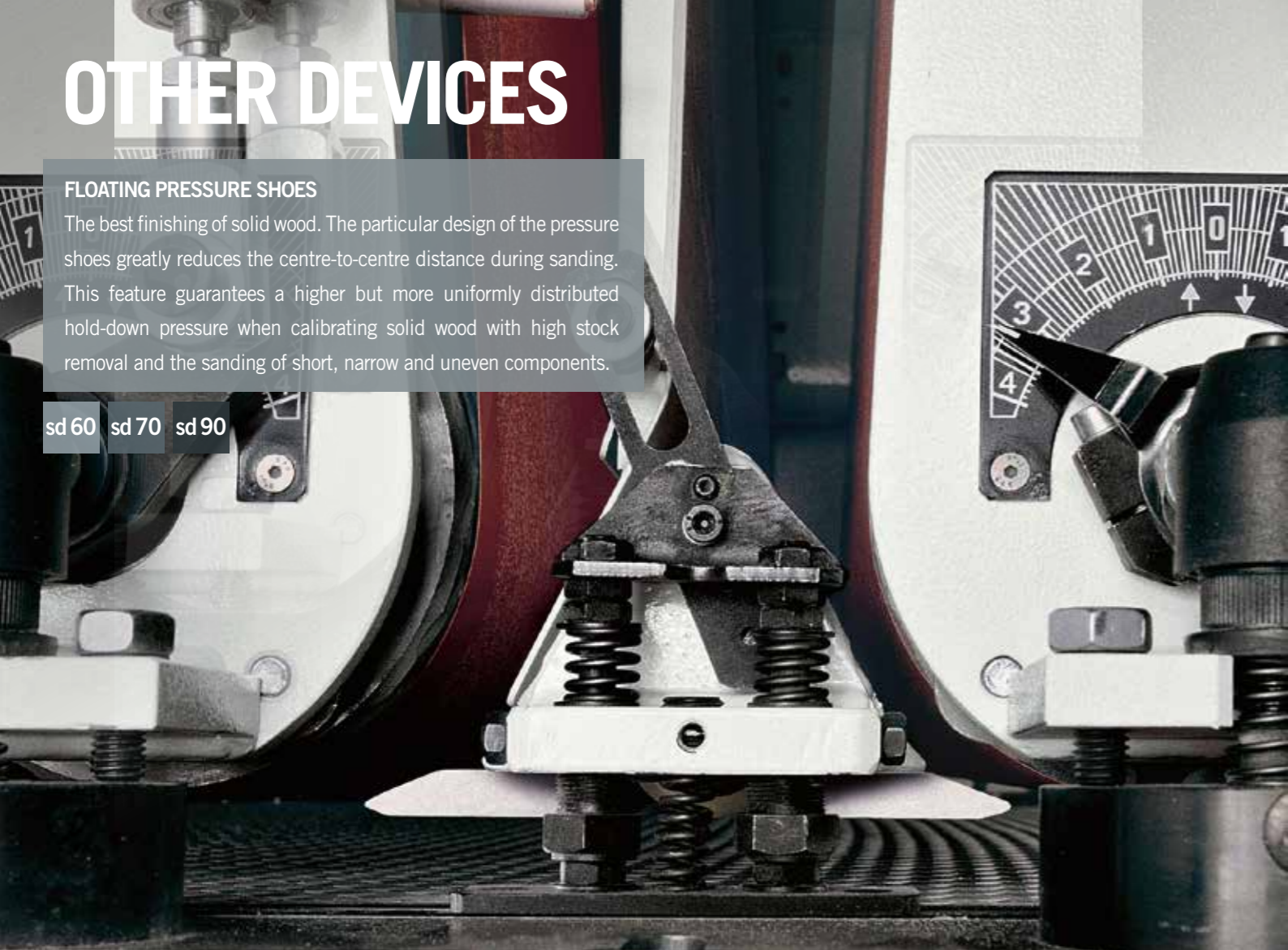

## ROTATING BLOWERS

The rotating blowers gently remove dust from sanded components. To reduce the consumption of compressed air to a minimum, the unit operation is timed and the blowers only operate when a component is present in the machine.

sd 60 sd 70 sd 90



## LED INDICATOR FOR PANEL INTRODUCTION

Simple and intuitive, communicating to the operator where and when the panel has to be introduced into the machine and optimising the standard wear of the sanding belt; this ensures a better quality finish and reduced machine costs.

sd 30 sd 60 sd 70 sd 90



## AUTOMATIC FEED BELT CENTERING

An electro-pneumatic system keeps the feed belt on track, perfectly centred and tensioned at all times. The system is automatic and no operator intervention is required.

sd 30 sd 60 sd 70 opt. sd 90

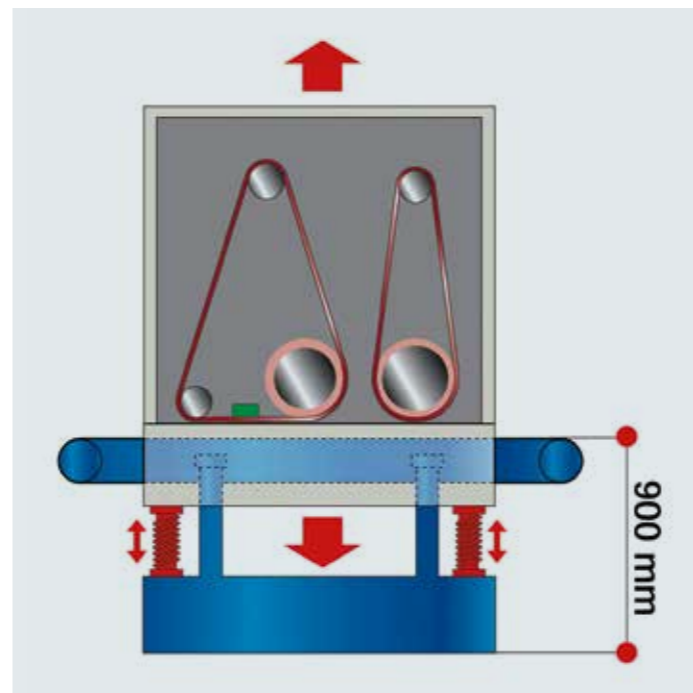

## WORKTABLE AT FIXED HEIGHT

Ease of use. The version with 900 mm fixed height worktable allows the roller conveyors or belt transfer units to be positioned at the machine infeed and/or outfeed, to facilitate the machining of long and heavy work pieces.

sd 70 sd 90

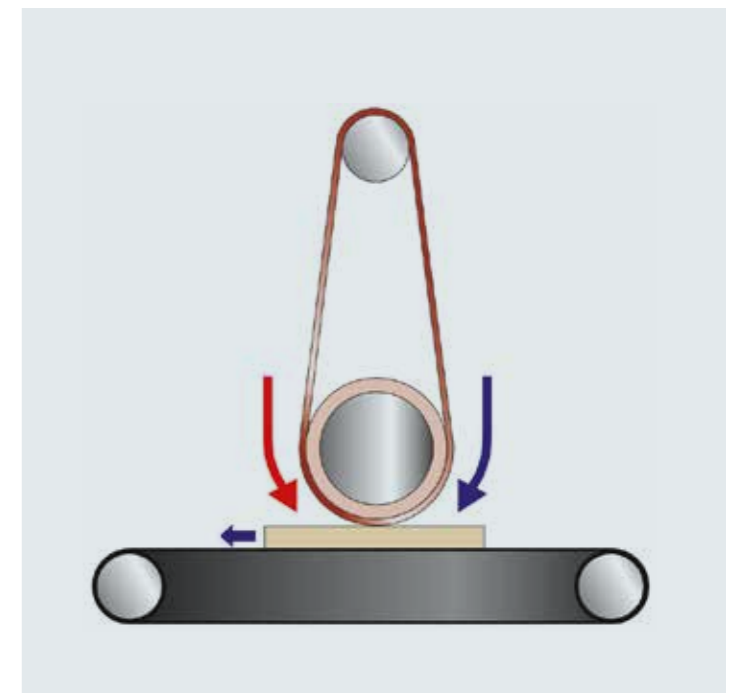

## REVERSE ROTATION OF THE SANDING BELT

Ideal for the water-based paints. With dedicated exhaust hoods this is the perfect solution for solid wood pre-sanding as it removes any fibers that remain following calibration.

sd 60 sd 70 sd 90

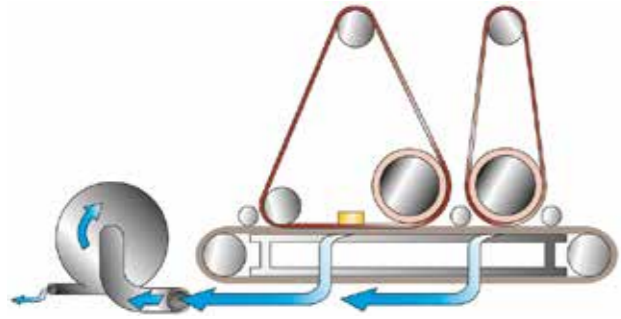

### VACUUM TABLE WITH DIAMOND-SHAPED BELT

No slipping of the work piece. The best traction surface and the maximum stability for the panels are provided by the special geometry of the diamond-shaped profile of the transport belt.

sd 60 sd 70 sd 90

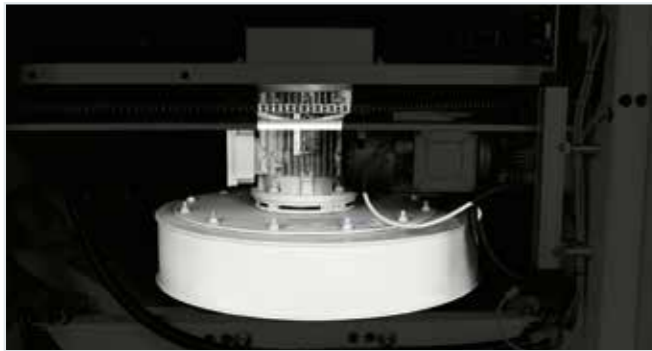

### INTEGRATED ELECTRO-FAN, GIVING EXTREME COMPACTNESS

Reduced overall dimensions and noise emissions with the fan positioned under the work table.

sd 70 sd 90

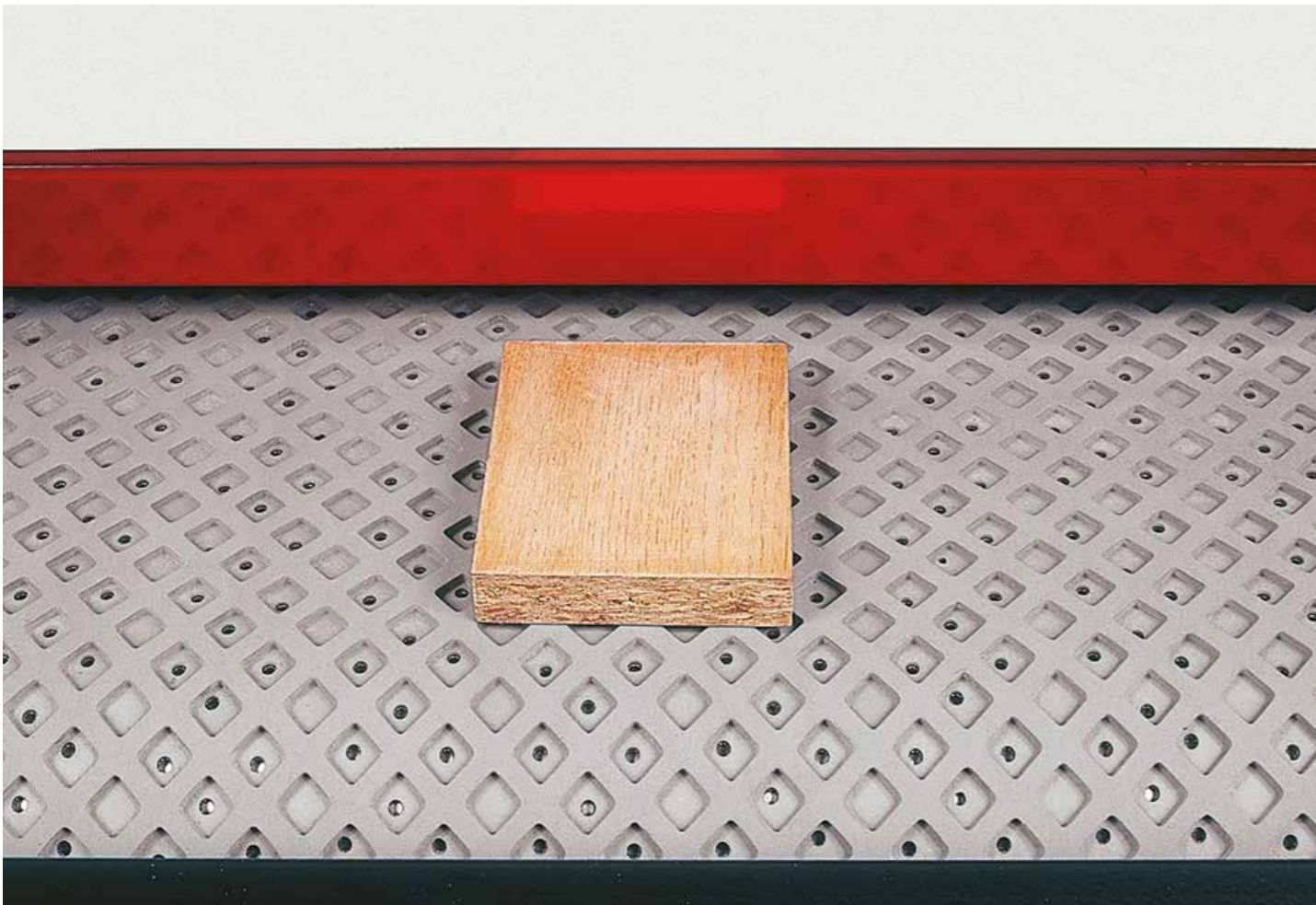

### BELT OSCILLATION CONTROLLED BY AN ELECTRONIC PHOTOCELL

This precision control system ensures the maximum uniformity in belt oscillation: this reduces the risk of belt breakage and improves finishing quality.

sd 30 sd 60 sd 70 sd 90



### TIMED OSCILLATING BELT CLEANING BLOWER

Electronically controlled timing and only when a component is present in the machine guarantees reliability over time and reduces compressed air consumption to a minimum. Particularly advisable when machining painted work pieces.

sd 30 sd 60 sd 70 sd 90

# MACHINE CONTROLS



## “LOGIC SC” ELECTRONIC PROGRAMMER

Easily avoiding mistakes. Simple and intuitive, allowing the operator to set all processing parameters in sequence and then launch them with the touch of a button. The possibility to store various work programs to retrieve the machine settings most commonly used makes it ideal even for unskilled operators.

sd 30 sd 60 sd 70 sd 90



## “PRO-SAND” ELECTRONIC PROGRAMMER

Technology at your service.

Powerful and reliable, it is fitted with a touch-screen making all machine functions quick and easy to operate.

- 5,7” or 10,4” LCD colour display

- 120 working programs

sd 60 sd 70 sd 90

# TECHNICAL DATA

**dmc sd range**  
automatic wide belt sanders

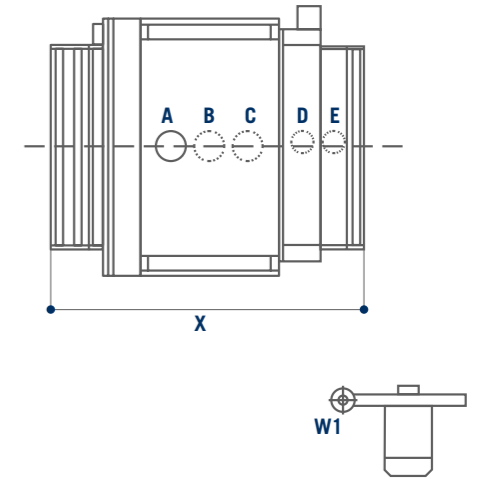

# STANDARD EQUIPMENT AND OPTIONS

	sd 30	sd 60	sd 70	sd 90
Working width	950 mm 1100 mm	1100 mm 1350 mm	1350 mm	1350 mm
Abrasive belts length	1900 mm	2150 mm	2620 mm	2620 mm
Main working units	1-2	1-2-3	2-3	1-2-3
Max. motor power (50 hz)	18,5 kW	18,5 kW	18,5 kW	20 kW
Independent motors	-	opt	opt	opt
Roller diameter (CS unit)	140 mm	160 mm	160 mm	175 mm
Roller diameter (R unit)	120 mm	140 mm 175 mm 250 mm	160 mm 175 mm 250 mm	175 mm 220 mm 250 mm 320 mm
Planer Unit (HPL)	-	opt	-	opt 180 mm
Buffing unit	-	opt	opt	opt
Structuring unit	-	opt	opt	opt
Electronic sectional pad	opt 55 mm	opt 55 mm 30 mm	opt 55 mm 30 mm	opt 55 mm 30 mm
Crossbelt unit	-	-	-	opt 5000 mm
Brushing unit	/	opt (1350)	opt	opt
Vacuum table	-	opt	opt	opt
Fixed table	-	-	opt	opt

## HOODS DIAMETER

	dmc sd 30	dmc sd 60	dmc sd 70	dmc sd 90	
	95-110	110-135	135	135	Working width
A	140	160	195	195	First unit
B	140	160	195	195	Second unit
C+		160	195	195	Third unit
D		160	160	160	Operating unit
E		160	160	160	Rotating blowers
W1		66	-	-	Internal vacuum
W2			150	150	External vacuum

## MACHINE DIMENSIONS

	dmc sd 30	dmc sd 60	dmc sd 70	dmc sd 90	
	95-110	110-135	135	135	Working width
X	1820	1920	195	2190	Version with 1 or 2 working units
X	-	2190	195	2580	Version with 3 working units
Y	1500-1650	1650-1900	195	1900	Machine width
Z	1960	2030	160	2390	Machine with mobile table
Z	-	-	160	2390-2590	Machine with fixed table



## POWER ONLY WHEN IT IS REQUIRED

SavEnergy allows the use of power only when it is required, making things operate only when they are really necessary. It means the machine automatically enters “stand-by” mode when there are no panels to be machined.

**COMPANY WITH  
QUALITY SYSTEM  
CERTIFIED BY DNV GL  
= ISO 9001 =**

*The technical data can vary according to the requested machine composition. In this catalogue, machines are shown with options. The company reserves the right to modify technical specifications without prior notice; the modifications do not influence the safety prescribed by CE Norms.*

# PROMPT AND EXPERT TECHNICAL SUPPORT THROUGH A NETWORK OF 1000 TECHNICIANS AND AN INVENTORY OF 36,000 SPARE PARTS.

HIGHLY SPECIALISED TECHNICIANS, EFFICIENT  
MANAGEMENT AND 6 SPARE PARTS BRANCHES  
AROUND THE WORLD GUARANTEE A CLOSE,  
SAFE AND EFFECTIVE TECHNICAL SUPPORT.

## SERVICE: A CONTINUOUS COMMITMENT TO PROTECT YOUR INVESTMENT

### SERVICE

SCM provides a service that goes beyond the purchase, to guarantee the long term performance of your technological production system and peace of mind for your business.

#### A COMPLETE RANGE OF AFTER-SALES SERVICES

- installation and start-up of machines, cells, lines and systems
- tailored training programs
- telephone support to reduce times and costs when machines are not working
- preventive maintenance programs to guarantee long term performance
- complete renovation of machines and plants to renew the added value of the investments
- custom upgrading to update machines and plants and meet new production requirements

### SPARE PARTS

SCM Group can count on 140 spare parts professionals worldwide to meet any request with real time shipments.



#### 36,000 SPARE PARTS

Our spare parts inventory, with a value of 12 million euros, covers every single machine



#### SPARE PARTS GUARANTEED

We guarantee also hard to find parts, with 3,5 million euros invested in "critical" spare parts.



#### IMMEDIATE AVAILABILITY

Over 90% of orders received are carried out the same day thanks to the huge inventory available.



#### 6 BRANCHES AROUND THE WORLD

The spare parts service can count on worldwide support (Rimini, Singapore, Shenzhen, Moscow, Atlanta, São Bento do Sul)



#### 500 SHIPMENTS A DAY



# THE STRONGEST WOOD TECHNOLOGIES ARE IN OUR DNA

## SCM. A HERITAGE OF SKILLS IN A UNIQUE BRAND

Over 65 years of success gives SCM the centre stage in woodworking technology. This heritage results from bringing together the best know-how in machining and systems for wood-based manufacturing. SCM is present all over the world, brought to you by the widest distribution network in the industry.

- 65 years history
- 3 main production sites in Italy
- 300.000 square metres of production space
- 20.000 machines manufactured per year
- 90% export
- 20 foreign branches
- 400 agents and dealers
- 500 support technicians
- 500 registered patents

In SCM's DNA also strength and solidity of a great Group. The SCM Group is a world leader, manufacturing

## SCM GROUP, A HIGHLY SKILLED TEAM EXPERT IN INDUSTRIAL MACHINES

### INDUSTRIAL MACHINERY

Stand-alone machines, integrated systems and services dedicated to processing a wide range of materials.



WOODWORKING TECHNOLOGIES



TECHNOLOGIES FOR PROCESSING COMPOSITE MATERIALS, ALUMINIUM, PLASTIC, GLASS, STONE, METAL

industrial equipment and components for machining the widest range of materials.

## AND COMPONENTS

### INDUSTRIAL COMPONENTS

Technological components for the Group's machines and systems, for those of third-parties and the machinery industry.



SPINDLES AND TECHNOLOGICAL COMPONENTS



ELECTRIC PANELS



METALWORK



CAST IRON



**SCM GROUP SPA**

via Casale 450 - 47826 Villa Verucchio, Rimini - Italy  
tel. +39 0541 674111 - fax +39 0541 674274  
scm@scmgroup.com  
www.scmwood.com



00L0365644H



REV. N. 01 - 03.2021 - MFC STUDIO



SCM GROUP SPA  
via Casale 450 - 47826 Villa Verucchio, Rimini - Italy  
tel. +39 0541 674111 - fax +39 0541 674274  
scm@scmgroup.com  
www.scmwood.com



00L0592603G



# All “Made in SCM Italy”

## From casting iron to finished product.

Come see our production plants and touch the quality of SCM machines; you will be our guest.



### Classical machines for the advanced joinery.

SCM's objective is to guarantee customers high quality technologies which meet their requirements in such a way as to make SCM the partner for any needs.

## nova range

Guaranteed quality at your fingertips.

circular saws	programmable	<b>nova si 400ep</b> page 6	<b>nova si x</b> page 18				
	manual	<b>nova si 400</b> page 7	<b>nova si 300</b> page 8	<b>nova si 300s</b> page 9	<b>nova si 40</b> page 19	<b>nova si 30</b> page 19	
planers	surface planers	<b>nova f 520</b> page 28	<b>nova f 410</b> page 28				
	thicknessing planers	<b>nova s 630</b> page 29	<b>nova s 520</b> page 29				
	surfacing-thicknessing planers	<b>nova fs 520</b> page 30	<b>nova fs 410</b> page 31				
spindle moulders	manual	<b>nova tf 110</b> page 38	<b>nova tf 100</b> page 38	<b>nova ti 105</b> page 39			

The motors powers in this catalogue are expressed in S6, except where otherwise specified. In this catalogue, machines are shown in CE configuration and with options.

We reserve the right to modify technical specifications without prior notice, provided that such modifications do not affect safety as per CE norms.



# APP Thundercut

Technology at your fingertips

SCM Thundercut is the Optimizer/Sequencer App for mobile devices that allows to optimize the panel surface and guides the operator through the cutting sequence.

High cut speed execution, less material waste and mistake odds minimized, even for not skilled workers!

Download it now from the AppStore and Google Play:

SCM Thundercut



technologycenter

## SCM CLASSICAL MACHINES, QUALITY EVEN MORE GUARANTEED

Since 1952, SCM has been leader in the design and production of woodworking machines.

We are getting closer to reach 70 years of company history by offering to our customers knowledge and advanced technologies that distinguish **L'invincibile, class** and **nova** classical machines.

Different ranges united by the strength points: performance, ease-of-use and certified quality. We believe so much in the reliability of our machines to offer to our customers the possibility to have a **warranty extended up to 2 years\***. An extra peace of mind for small artisans workshops and joineries who see SCM as the ideal partner to grow their business.

To activate the 2-year warranty extension, it is compulsory to register on-line the machine on the website:

[scmwood.com/warranty-extension](http://scmwood.com/warranty-extension)

\*Check the models of machines that can take advantage of the initiative on the website:

[scmwood.com/joinery-machines](http://scmwood.com/joinery-machines)

You can manage your circular saws fleet, the material warehouse and many project you are working on.



The 3D sequencer, thanks to its simple and clear design, suggest the ideal settings of the machine for every single cut to be executed.

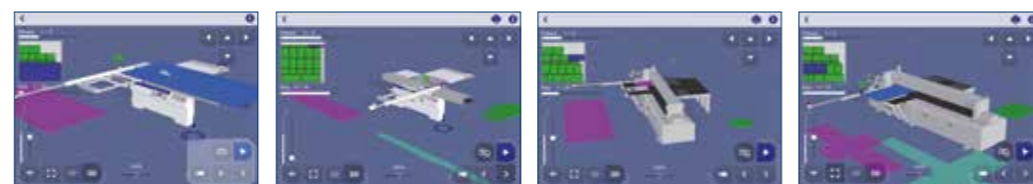

The App is available for circular saws, circular saws with movable blade unit, saw-shaper combination machines and universal combination machines (you will find the QR code to activate the App in each new machine).





## programmable circular saw nova si 400ep



## manual circular saw nova si 400



		nova si 400ep	nova si 400
Max. saw blade diameter <b>with installed scoring unit</b>	mm	400	400
Max. saw blade projection from the table at 90°/45°	mm	140/97	140/97
Saw blade rotating speed	rpm	3000/4000/5000	3700
Squaring stroke	mm	3200 ÷ 3800	3200 ÷ 3800
Cutting width on rip fence	mm	1000 ÷ 1500	1000 ÷ 1500
Three-phase motors power starting from	kW/Hz	7 (8) / 50 (60)	7 (8) / 50 (60)

Find the complete technical specification at page 16

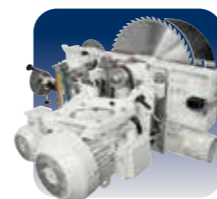

**Saw Unit**  
sturdy structure

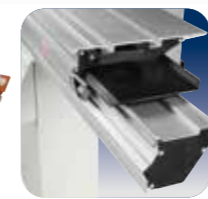

**Sliding Carriage**  
high cutting quality

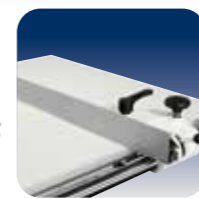

**Rip Fence**  
rapidity and accuracy



**SCM Thundercut**  
Optimizer/  
Sequencer App

High construction quality for reliability and safe performance.



# manual circular saw nova si 300



# manual circular saw nova si 300s



		nova si 300	nova si 300s
Max. saw blade diameter <b>with installed scoring unit</b>	mm	315	315 ÷ 400
Max. saw blade projection from the table at 90°/45°	mm	100/70	100/70 (with 315 mm blade) 140/97 (with 400 mm blade)
Saw blade rotating speed	rpm	4000	4000 (with 315 mm blade) 3700 (with 400 mm blade)
Squaring stroke	mm	3200 ÷ 3800	1600
Cutting width on rip fence	mm	1000 ÷ 1500	1000 ÷ 1500
Three-phase motors power starting from	kW/Hz	5 (6) / 50 (60)	5 (6) / 50 (60) (with 315 mm blade) 7 (8) / 50 (60) (with 400 mm blade)

Find the complete technical specification at page 16

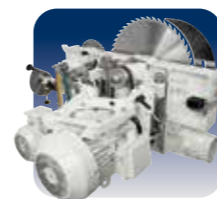

Saw Unit  
sturdy structure

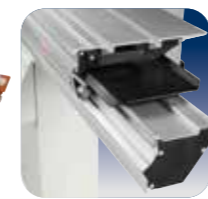

Sliding Carriage  
high cutting quality

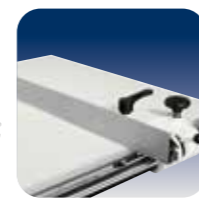

Rip Fence  
rapidity and  
accuracy



SCM  
Thundercut  
Optimizer/  
Sequencer App

Essential configuration with complete equipment to carry out professional machining.

# circular saws operating groups



## sturdy structure

### Saw Unit

The saw blade lifting is carried out by a strong cast-iron structure with sliding on ground round slideways which guarantee the **best accuracy**. The unit tilting is carried out on cast-iron rotation sectors in a crescent shape to ensure reliability over time.

always user friendly and precise

### Handwheels on the machine front

Ease-of-use in every day operation due to the dedicated gear box (**SCM solution**), fully protected from dust, that provides a smooth and direct transmission.

Every minimum hand-wheel movement corresponds to a precise blade adjustment.



perfect cut

### Saw unit

Maximum torsional rigidity and the total absence of vibration through the closed loop structure of the saw unit which ensures **perfect alignment of the blades** during tilted and difficult cuts.

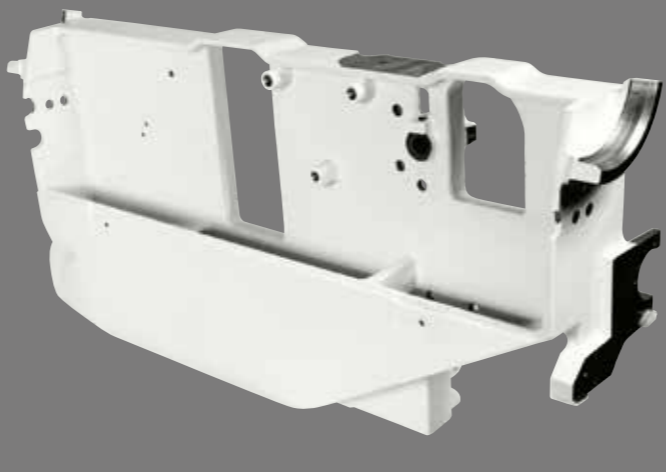

simple and effective

### Scoring unit adjustment

Vertical and horizontal adjustments are carried out by user-friendly mechanical levers that operate directly making **precise and smooth movements**. The useful mechanical stops allow immediately finding of the set position. The positioning of the controls allows their use without moving from the front of the machine.



smooth, rapid and precise positioning

### Rip fence

Sliding of the rip fence support on round bar with micrometric adjustment.

The support can be also equipped with digital readout for fence position with detecting system on magnetic band (option). The fence can be easily excluded from the working area when it isn't used.



maximum cut quality guaranteed over time

### Sliding carriage

The carriage will never require adjustment due to its closed reticular geometry with steel guides using an **exclusive method of mechanical fixing**.



reliability and technology without comparison  
10 years of SCM guarantee for the carriage sliding system.



optimal support

### Squaring frame and fence

Panel loading is easy on the large squaring frame with an idle roller at the end and the mobile cross beams offer an **optimal support** also to smaller panels. The telescopic squaring fence with the inclined metric scale and two reversible stops can be used to square panels measuring 3200x3800 mm and for tilted cuts at up to 45° on both sides of the frame.

# nova si 400ep electronic controls



the practical advantage for automatic control of the main positions

- Ready**  
The programming of the work becomes **simple and effective** with the electronic control with a 4" LCD display.
- Working mode: manual, semi-automatic and automatic with a memory capacity of up to 99 programs
  - Tool data setting with automatic height adjustment
  - Calculator and hour counter

# circular saws main optional devices

Tablet holder on the sliding carriage  
Compatible with tablets from 8" to 11".



**Adjustable tablet holder positioned on the mobile control panel**  
Compatible with tablets from 7" to 13".  
It is equipped with USB port for power supply positioned on the mobile control panel.

speed and accuracy  
**Motorised programmable rip fence mounted on a recirculating ball screw mechanism with sliding on linear guides.**  
*Only for Ready 3 UP Plus version*



- Saw unit lifting
- Saw unit tilting
- Programmable rip fence (option)
- Blade speed readout

practicality and safety  
**Motorized programmable rip fence with steel cable and sliding on sturdy round steel bar.**  
Position readout on magnetic band.  
*Only for Ready 3 version*



**Rip fence unit**  
The exclusive referencing system for the first trim cut allows the setting of trim quantity to be cut for every side **without any test cuts.**



**Angular cutting devices**  
Available for the following versions  
a) traditional  
b) with automatic self-adjustment of the stops position in respect of the blade

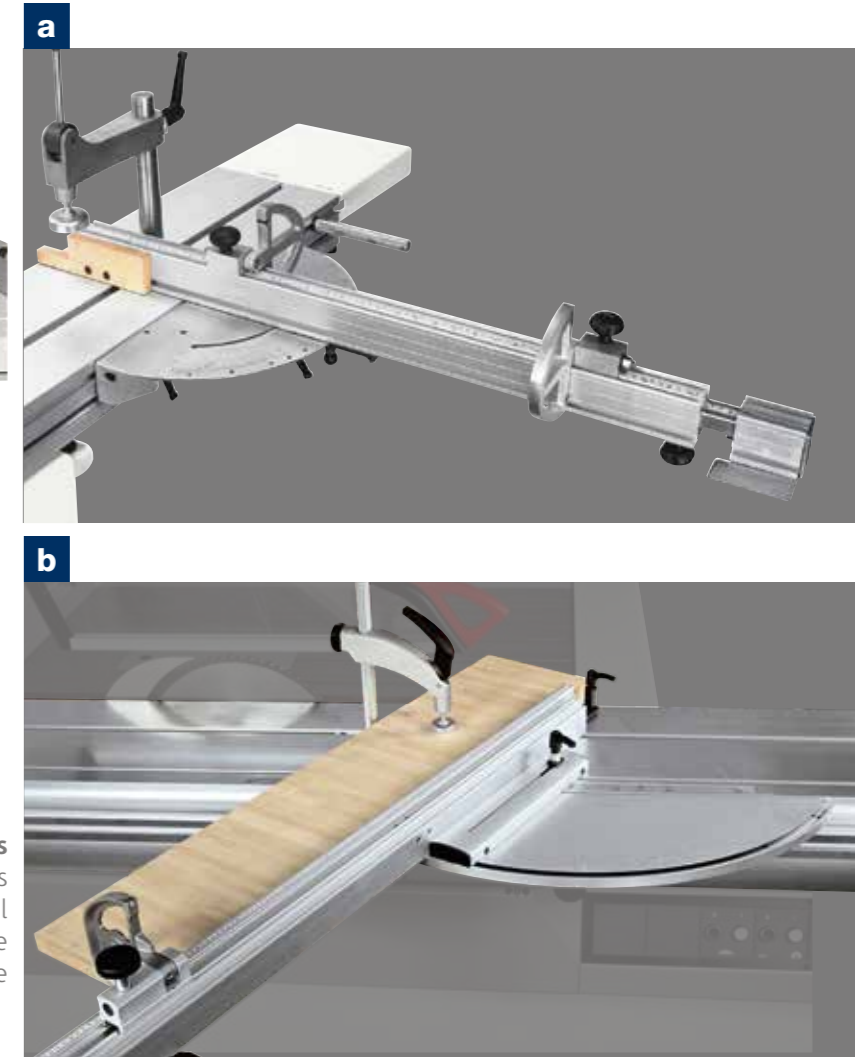

circular  
saws  
main  
optional  
devices

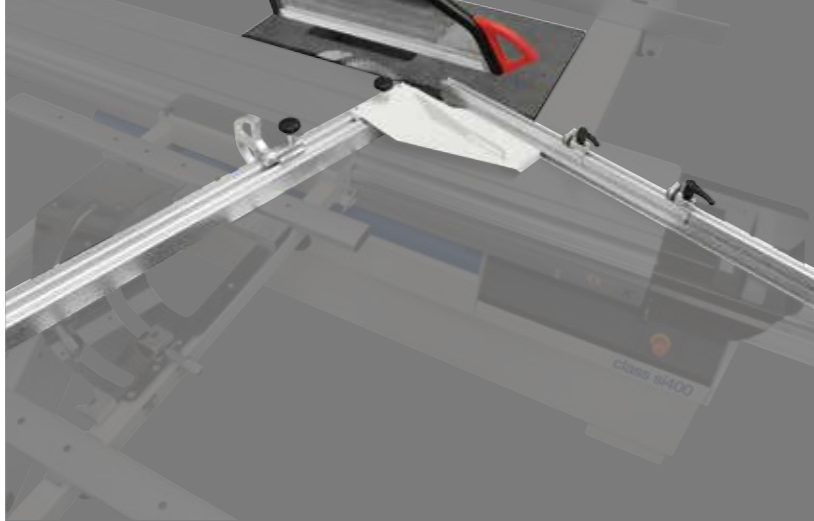

**Fence for complementary cutting**  
Device to be applied directly on the squaring rule that allows to quickly carry out cuts with angles complementary to the rule one.



**Expandable scoring blade**  
Manually expandable with variable thickness from 2,8 to 3,6 mm. Blade diameter: 120 mm.



**maximum practicality**  
**Pushbuttons integrated in the sliding carriage**  
The possibility to start or stop the blades motors from the pushbuttons located at the ends of the carriage **considerably helps when machining large dimensioned panels.**

**Squaring frame with "Compex" device**  
with automatic self-adjustment of stops position in respect of the blade and rule tilting angle. Furthermore, thanks to the dedicated frame structure, it is possible to carry out **tilted cuts keeping the squaring rule comfortably within the operator's reach**, both in acute cuts and in obtuse ones, without renouncing to a valid support of the piece.



**"LED indicating scoring unit in operation" device**  
When the scoring blade is working, the high efficiency LEDs clearly indicate the danger area, making the machine safer than ever.



**Mechanical preset for "DADO" machining**  
Possibility of using a tool (not included) to replace the main blade, with 203 mm maximum diameter and 20 mm maximum thickness.

**Electronic readouts on the squaring stops**  
The stops can be easily read even from distance.



**Advanced materials machining**  
PVC and other plastic materials. Nylon, polycarbonate and other synthetic materials. Corian and other composite materials. Aluminium, brass and other light metals.



**Device for the blade micro-lubrication**  
Compulsory for the machining of light alloys, extremely useful with particular plastic materials.

# circular saws technical data

S Standard  
O Option

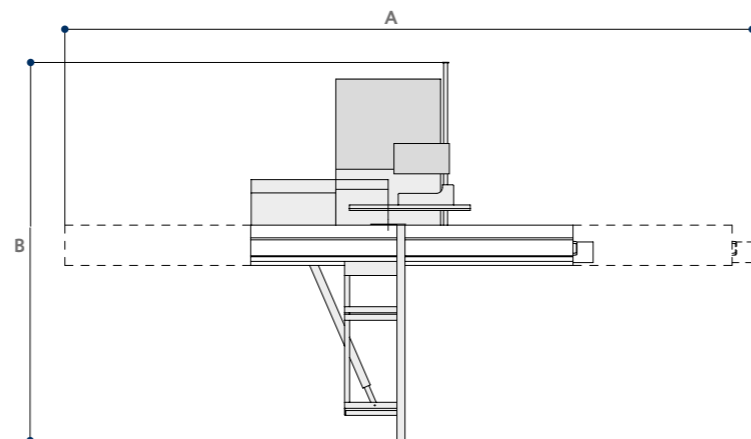

TECHNICAL DATA		nova si 400ep	nova si 400	nova si 300	nova si 300s
Cast-iron saw table dimensions	mm	1040 x 630	1040 x 630	900 x 550	900 x 550
Blades tilting		90° ÷ 45°	90° ÷ 45°	90° ÷ 45°	90° ÷ 45°
Max. saw blade diameter <b>with installed scoring unit</b>	mm	400	400	315	315 ÷ 400
Max. saw blade projection from the table at 90°/45°	mm	140/70	140/97	100/97	100/70 (with 315 mm blade) 140/97 (with 400 mm blade)
Saw blade rotating speed	rpm	3000/4000/5000	3700	4000	4000 (with 315 mm blade) 3700 (with 400 mm blade)
Squaring stroke	mm	3200 ÷ 3800	3200 ÷ 3800	3200 ÷ 3800	1600
Cutting width on rip fence	mm	1000 ÷ 1500	1000 ÷ 1500	1000 ÷ 1500	1000 ÷ 1500
<b>other technical features</b>					
Three-phase motors 5 kW (6,6 hp) 50 Hz - 6 kW (8 hp) 60 Hz		-	-	S	S
Three-phase motors 7 kW (9,5 hp) 50 Hz - 8 kW (11 hp) 60 Hz		S	S	O	O
Three-phase motors 9 kW (12 hp) 50 Hz - 11 kW (15 hp) 60 Hz		O	O	-	-
Three-phase motors 14 kW (19 hp) 50 Hz - 14 kW (19 hp) 60 Hz		-	-	-	-
Exhaus hoods diameter:					
- at the base	mm	120	120	120	120
- on overhead protection	mm	80	80	80	80
- on riving knife	mm	-	60	60	60

## OVERALL DIMENSIONS

		nova si 400ep	nova si 400	nova si 300	nova si 300s
A with 1600 mm carriage	mm	-	-	-	3760
A with 3200 mm carriage	mm	7100	7100	7100	-
A with 3800 mm carriage	mm	8140	8140	8140	-
B with 1000 mm cutting width on rip fence	mm	4870	4870	4870	3115
B with 1270 mm cutting width on rip fence	mm	5155	5155	5155	3400
B with 1500 mm cutting width on rip fence	mm	5370	5370	5370	3615

## MAIN OPTIONAL DEVICES

	nova si 400ep	nova si 400	nova si 300	nova si 300s
"Ready 3" version	O	-	-	-
"Ready 3 UP" version	O	-	-	-
"Ready 3 UP Plus" version	O	-	-	-
"CUT 140" version	-	-	-	O
"SCM Thundercut" Optimizer/Sequencer App	S	S	S	S
Expandable scoring blade	O	O	O	O
Pushbuttons integrated in the sliding carriage	O	O	O	-
Squaring fence with LCD readouts for stops position	O	O	O	-
Fence for angular cutting on the sliding carriage	O	O	O	O
Fence for angular cutting with self-adjustment	O	O	O	O
Squaring frame with "Compex" device	O	O	O	-
Fence for complementary cutting	O	O	O	-
Fence for rip cutting on the sliding carriage	O	O	O	O
Electronic readout of parallel fence position	O	O	O	O
Adjustable tablet holder positioned on the mobile control panel	O	-	-	-
Tablet holder on the sliding carriage	O	O	O	O
"LED indicating scoring unit in operation" device	O	-	-	-
"DADO" machining	O	O	O	O
Machine configuration for advanced materials machining	O	O	O	O
Device for the blade micro-lubrication for the machining of plastic materials and light alloy	O	O	O	O
Overhead blades protection	S	S*	O	O

\* Standard for CE and USA-Canada versions; Option for NO CE version



# programmable circular saw nova si x



±46° double tilting blade.



# manual circular saws nova si 40 nova si 30



		nova si x	nova si 40	nova si 30
Max. saw blade diameter <b>with installed scoring unit</b>	mm	400	400	315
Max. saw blade projection from the table at 90°/+45°/-45°	mm	136/97/60	136/97/-	90/70/-
Saw blade rotating speed	rpm	4000	4000	4000
Squaring stroke	mm	2600 ÷ 3200	2600 ÷ 3200	2600 ÷ 3200
Cutting width on rip fence	mm	1270	1270	1270
Three-phase motors power starting from	kW/Hz	7	5	5

Find the complete technical specification at page 26

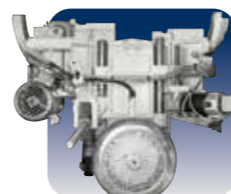

Saw Unit  
sturdy structure



Sliding Carriage  
unrivalled cutting  
finishing

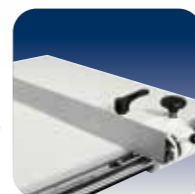

Rip Fence  
rapidity and  
accuracy



SCM  
Thundercut  
Optimizer/  
Sequencer App

Professional circular saws for uncompromising quality.

# circular saws operating groups

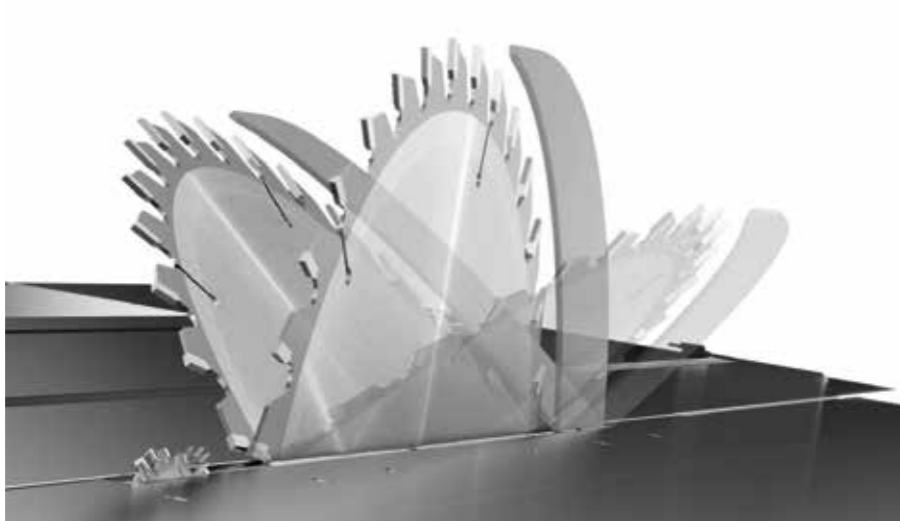

double tilting at everybody's reach

The  $\pm 46^\circ$  tilting of the unit is done by 2 wide semi-circular fences.

For *nova si x* the lifting of the blade unit is done by 2 ground cylindric bars.

The rotation fulcrums of the saw unit have a 120 mm diameter and stand on steady crescent shaped rests that separate it from the base: a rigid reliable solution.

For *nova si 40* and *nova si 30*, the lifting of the blade unit is done by a robust cast iron structure with dovetail system.

## sturdy structure Saw Unit

Saw units with a stiff cast-iron structure which can accommodate a blade of 400 mm diameter (315 mm for *nova si 30*) **with scoring blade installed**. They ensure a perfect and easy cutting of veneer panels and solid wood material with very high thickness. The saw blade uses 100% of the motor power, thanks to the scoring blade with an independent motor as standard.

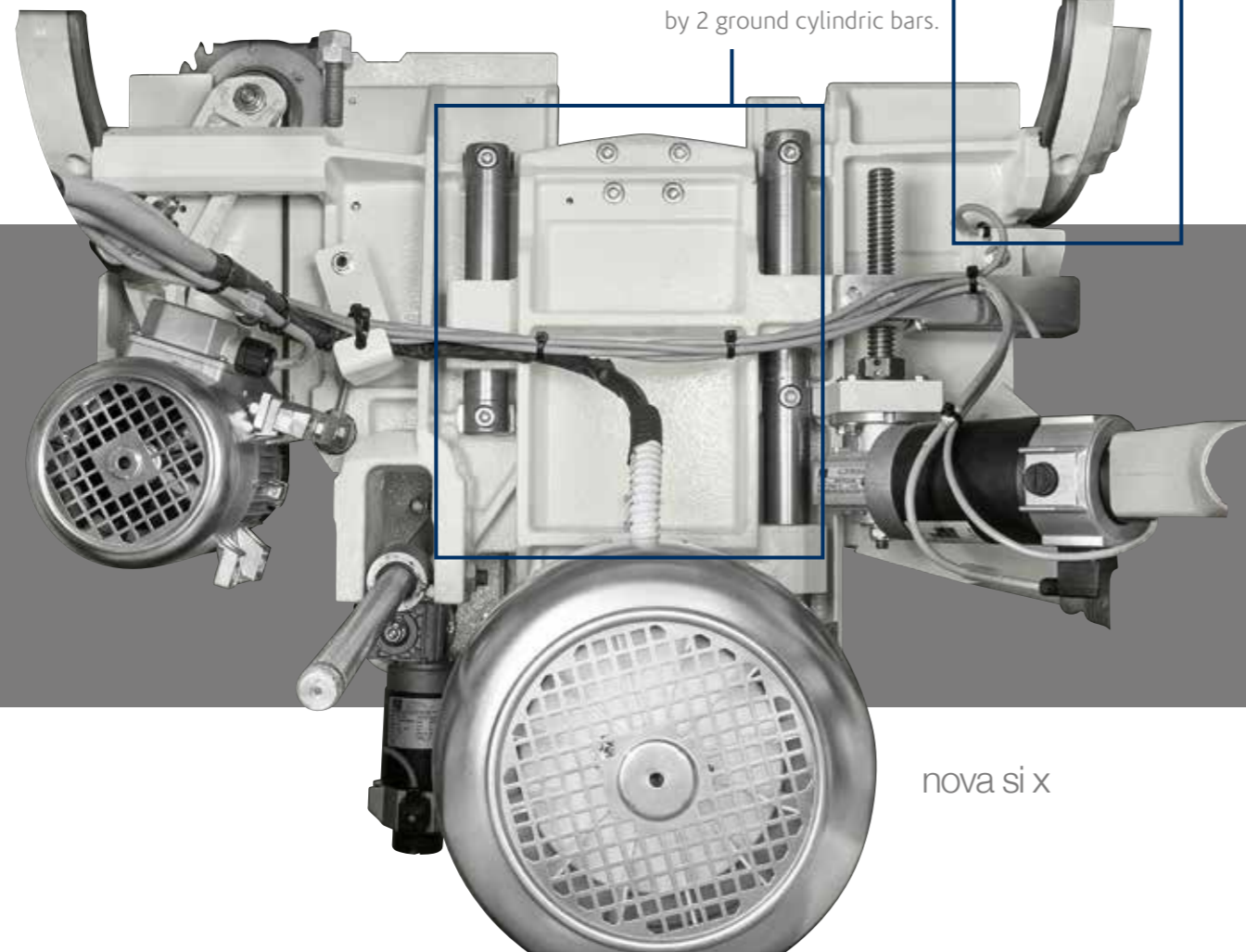

nova si x

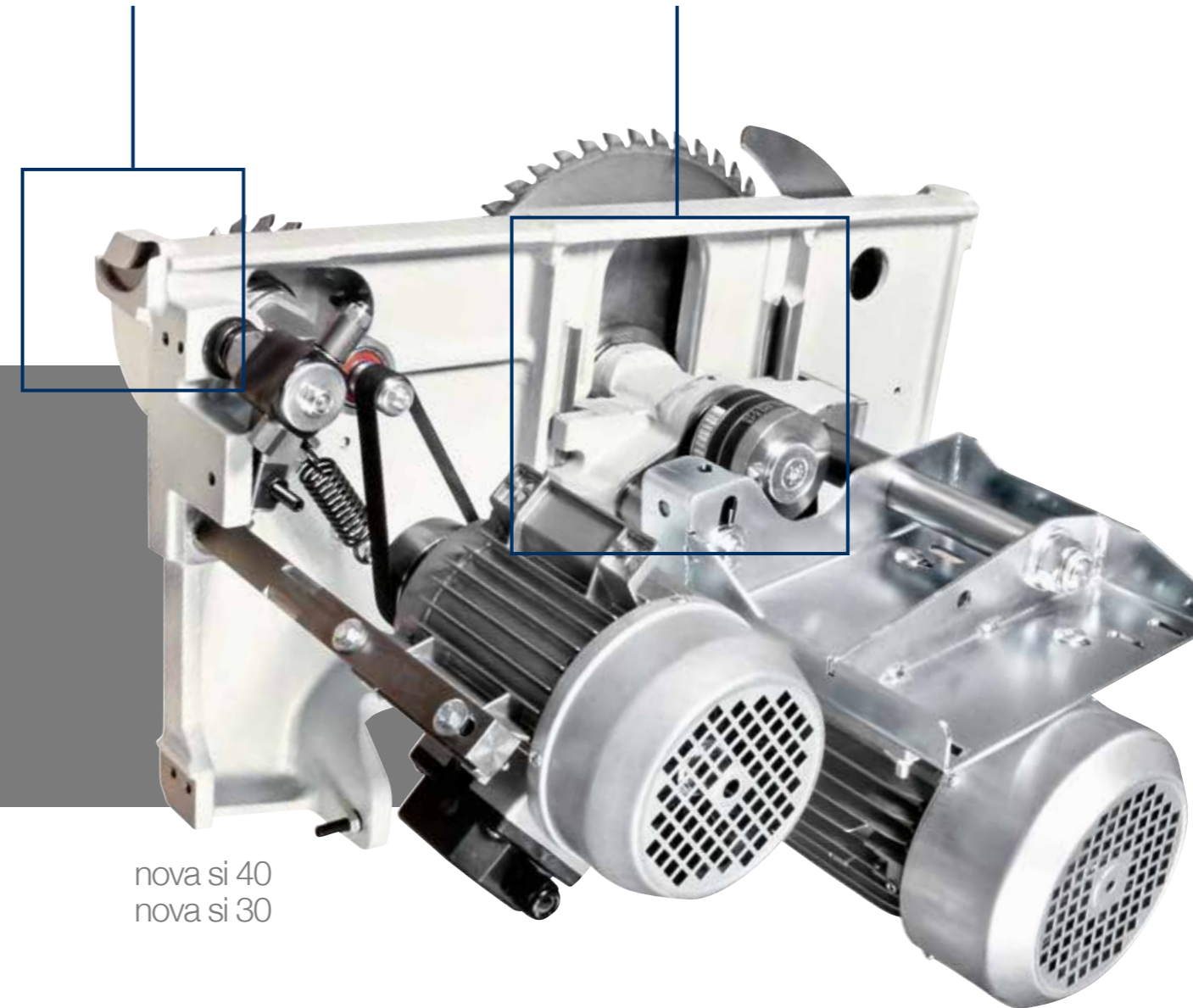

nova si 40  
nova si 30



The scoring blade is adjustable from the outside without tools and allows fast and accurate positioning with no play.

# circular saws operating groups



unrivalled cutting finishing  
**Sliding Carriage**  
 Optimal support also to larger pieces, with the **new sliding table, 360 mm wide.**



Exceptional accuracy and smoothness to secure the guides it is not used glue, since the thickness could affect sliding. They are secured with a **procedure of aluminum riveting.**

reliability and technology without comparison  
 10 years of SCM guarantee for the carriage sliding system.



immediate control  
**Squaring frame and fence**  
 Panel loading is easy on the large squaring frame with an idle roller at the end.  
**The telescopic squaring fence with the inclined metric scale and two reversible stops** can be used to square panels measuring 3200x3200 mm and for tilted cuts at up to 45° on both sides of the frame.

# circular saws optional electronic controls

simple and quick  
**Programmed movement**

The "Ready" control manages the powered and programmed movement of the saw blade unit increasing productivity and working quality.  
*(standard for nova si x)*

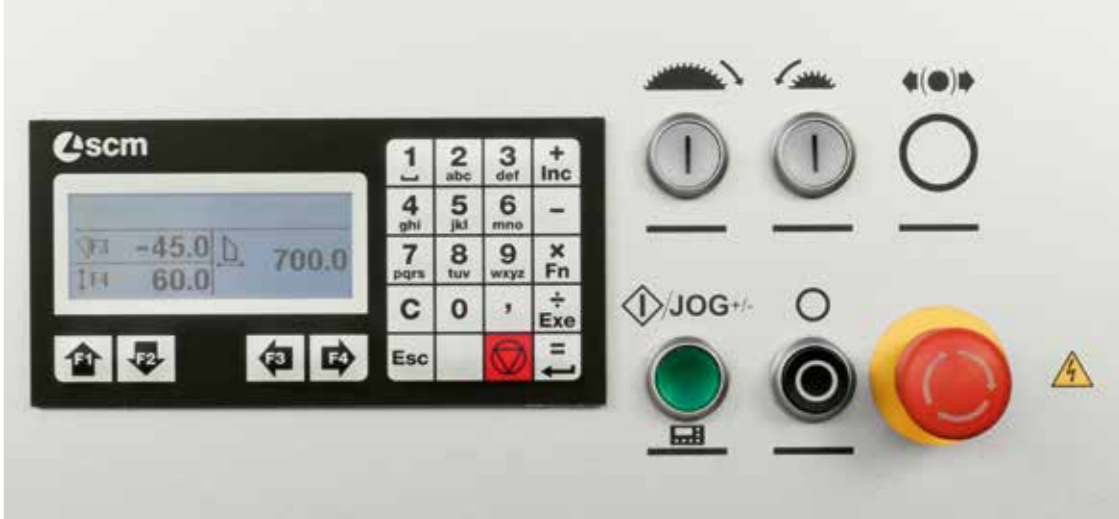

**Ready 3 / Ready 3 UP**  
**Automatic positioning of the parallel fence,** from "Ready" control (3 axes). Programmed or manual fence movement with a hold-down drive for the maximum versatility.  
**In addition, the Ready 3 UP version has the control on the mobile control panel.**

**Powered handling of the operating groups with digital readouts**  
 For the best accuracy and easy to use.



maximum practicality  
**Pushbuttons integrated in the sliding carriage**  
 The possibility to start or stop the blades motors from the pushbuttons located at the ends of the carriage **considerably helps when machining large dimensioned panels.**



**Two positions overhead blade protection,** for totally safe machining.  
*(nova si x)*



smooth, rapid and precise positioning  
**Rip fence**  
 Sliding of the rip fence support on round bar with micrometric adjustment.  
 The support can be also equipped with digital readout for fence position with detecting system on magnetic band (option). The fence can be easily excluded from the working area when it isn't used.



# circular saws main optional devices

**Squaring frame with "Compex" device** with automatic self-adjustment of stops position in respect of the blade and rule tilting angle. Furthermore, thanks to the dedicated frame structure, it is possible to carry out **tilted cuts keeping the squaring rule comfortably within the operator's reach**, both in acute cuts and in obtuse ones, without renouncing to a valid support of the piece.



**Digital readout for the fence position on the parallel fence**  
It allows precise positioning with the magnetic strip sensor.

**Mechanical preset for "DADO" machining**  
Possibility of using a tool (not included) to replace the main blade.

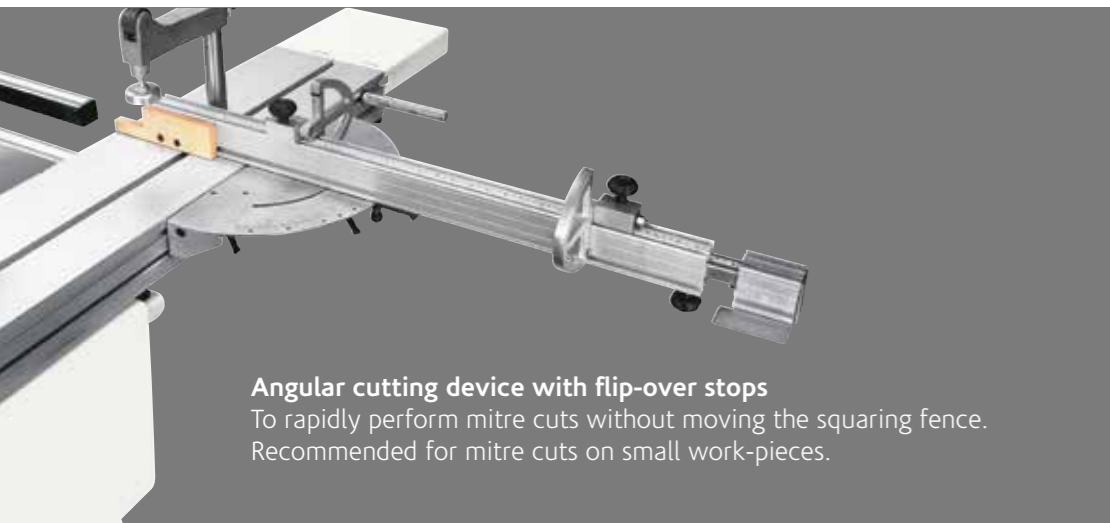

**Angular cutting device with flip-over stops**  
To rapidly perform mitre cuts without moving the squaring fence. Recommended for mitre cuts on small work-pieces.



**Electronic readouts on the squaring stops**  
The stops can be easily read even from distance.



**Expandable scoring blade**  
Manually expandable with variable thickness:  
- from 3,5 to 4,5 mm (blade diameter: 160 mm) *nova si x*  
- from 2,8 to 3,6 mm (blade diameter: 120 mm) *nova si 40* and *nova si 30*



**Device for the blade micro-lubrication**  
Compulsory for the machining of light alloys, extremely useful with particular plastic materials.

**Pre-set angular cutting device directly positioned on squaring frame**  
To find rapidly the most common angles with the squaring fence. Useful for large work-pieces.



**Additional table on the sliding carriage**  
For the support of large dimensioned panels.

**Tablet holder on the sliding carriage**  
Compatible with tablets from 8" to 11".



**Adjustable tablet holder positioned on the mobile control panel**  
Compatible with tablets from 7" to 13". It is equipped with USB port for power supply positioned on the mobile control panel.

# circular saws technical data

S Standard  
O Option

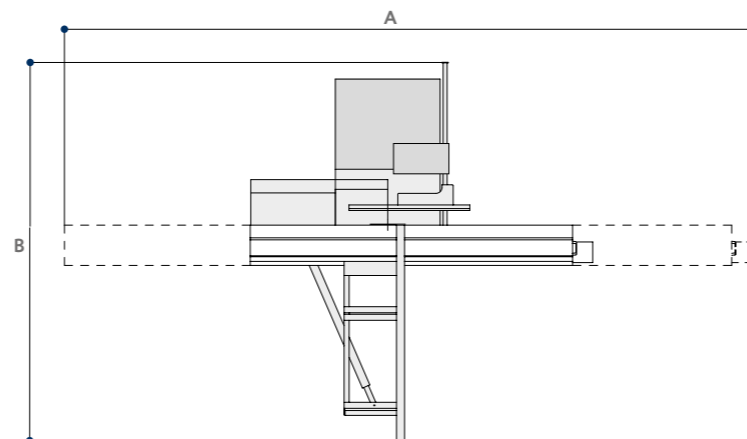

TECHNICAL DATA		nova si x	nova si 40	nova si 30
Cast-iron saw table dimensions	mm	1000 x 685	940 x 560	940 x 560
Blades tilting		-46° ÷ +46°	90° ÷ 45°	90° ÷ 45°
Max. saw blade diameter <b>with installed scoring unit</b>	mm	400	400	315
Max. saw blade projection from the table at 90°/+45°/-45°	mm	136/97/60	136/97/-	90/70/-
Saw blade rotating speed	rpm	4000	4000	4000
Squaring stroke	mm	2600 ÷ 3200	2600 ÷ 3200	2600 ÷ 3200
Cutting width on rip fence	mm	1270	1270	1270
<b>other technical features</b>				
Three-phase motors 5 kW (6,6 hp) 50 Hz - 6 kW (8 hp) 60 Hz		-	S	S
Three-phase motors 7 kW (9,5 hp) 50 Hz - 8 kW (11 hp) 60 Hz		S	O	O
Exhaus hoods diameter:				
- at the base	mm	120	120	120
- on overhead protection	mm	80	80	80
- on riving knife	mm	-	60	60

## OVERALL DIMENSIONS

		nova si x	nova si 40	nova si 30
A with 2600 mm carriage	mm	5860	5860	5860
A with 3200 mm carriage	mm	7060	7060	7060
B with manual rip fence	mm	3650	3650	3650
B with automatic rip fence	mm	4820	4820	4820

## MAIN OPTIONAL DEVICES

	nova si x	nova si 40	nova si 30
"Ready 3" version / Programmed parallel fence	O	O	-
"Ready 3 UP" version	O	O	-
"SCM Thundercut" Optimizer/Sequencer App	S	S	S
Powered handling of the operating groups with digital readouts	-	O	O
Pushbuttons integrated in the sliding carriage	O	O	O
N.2 sawblades speeds (3500/5000 rpm)	O	O	-
Electronic readouts on the squaring stops	O	O	O
Angular cutting device with flip-over stops	O	O	O
Pre-set angular cutting device directly positioned on squaring frame	O	O	O
Squaring frame with "Compex" device	O	O	O
Additional table on the sliding carriage	O	O	O
Digital readout for the fence position on the parallel fence	O	O	O
Adjustable tablet holder positioned on the mobile control panel	O	O	-
Tablet holder on the sliding carriage	O	O	O
Device for the blade micro-lubrication for the machining of plastic materials and light alloy	-	O	-
"DADO" machining	O	O	O**
Overhead blades protection	S	O*	O

\* Standard for CE and USA-Canada versions; Option for NO CE version

\*\* Not available for CE version

surface planers  
nova f 520  
nova f 410



thicknessing planers  
nova s 630  
nova s 520



		nova f 520	nova f 410	nova s 630	nova s 520
Working width	mm	520	410	630	520
Cutterblock diameter/standard knives	mm/n.	120/4	120/4	120/4	120/4
Total worktable length	mm	2750	2610	-	-
Max. stock removal	mm	8	8	8	8
Min. ÷ max. working height on thicknesser		-	-	3,5 ÷ 300	3,5 ÷ 300
Three-phase motors power starting from	kW/Hz	5 (6) / 50 (60)	5 (6) / 50 (60)	7 (8) / 50 (60)	7 (8) / 50 (60)

Find the complete technical specification at page 36

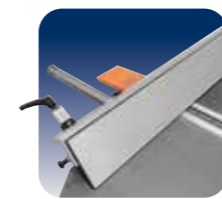

Surface Fence  
high rigidity

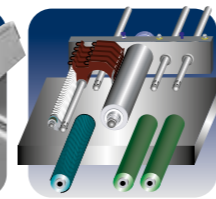

Interchangeable  
Rollers  
for every  
requirement

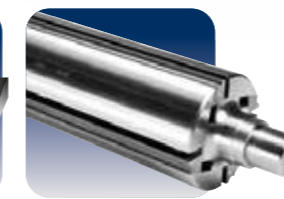

SCM Cutterblock  
simple and rapid

Perfect surfaces, practical  
and safe, ergonomics.

surfacing-thicknessing  
planers  
nova fs 520  
nova fs 410



		nova fs 520	nova fs 410
Working width	mm	520	410
Cutterblock diameter/standard knives	mm/n.	120/4	95/4
Total worktable length	mm	2250	2200
Min. ÷ max. working height on thicknesser	mm	3,5 ÷ 240	3,5 ÷ 240
Three-phase motors power starting from	kW/Hz	7 (8) / 50 (60)	5 (6) / 50 (60)

Find the complete technical specification at page 36

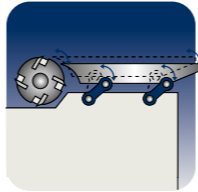

Feeding on Connecting Rods  
constant precision



Thickening Table  
rigidity and accuracy

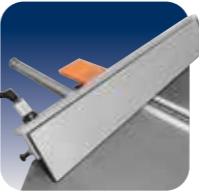

Surface Fence  
high rigidity

Easy and rapid to use with great performance in a limited space.

# planers operating groups



a guarantee of perfect planarity  
**Simultaneous raising of the worktables**  
The system allows the **changeover from planer to thicknesser** with a single movement ensuring working rapidity and accuracy.

high rigidity  
**Surface fence**  
High rigid fence with a smooth movement thanks to the **central locking on round bar**. The graduated scale facilitates the operator in positioning the guide to the required tilting.

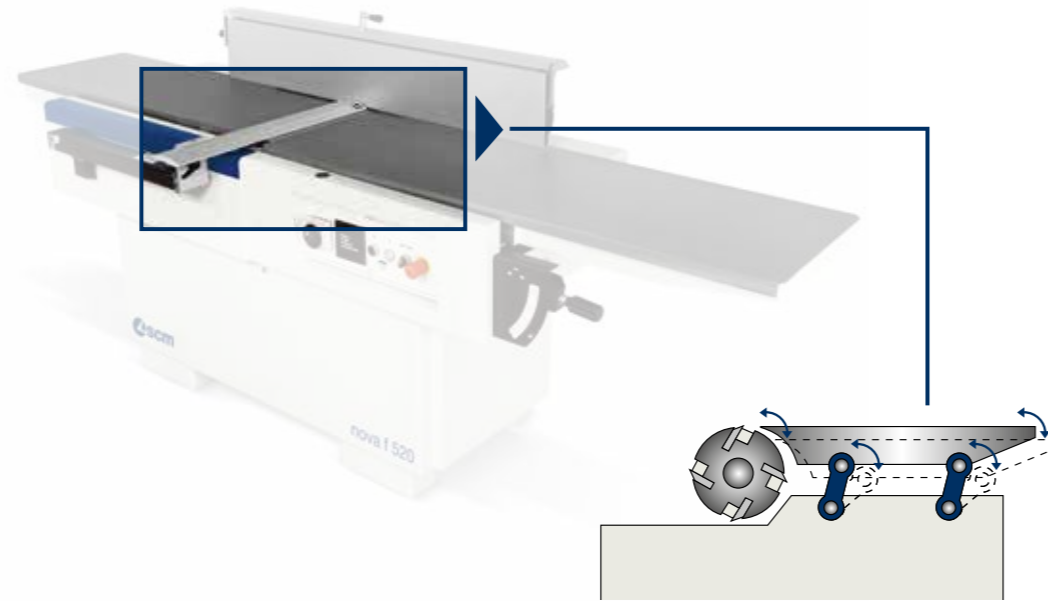

constant precision over time  
**Feeding on connecting rods**  
Very accurate machining with the movement of the infeed table by means of a parallelogram **kinetic mechanism which always gives the same distance between the cutterblock and the table**. The system operating directly on the connecting rods avoids any exertion to the table assuring constant planarity over time.



perfect finish  
**Feeding rollers on connecting rods**  
The stopping of the work-piece and the presence of notches on its surface are eliminated due to the movement system on all three rollers, that allows their vertical displacement by rotation and **the best linear feeding**. Perfect surfaces and high feeding performance with the standard rubber rollers.

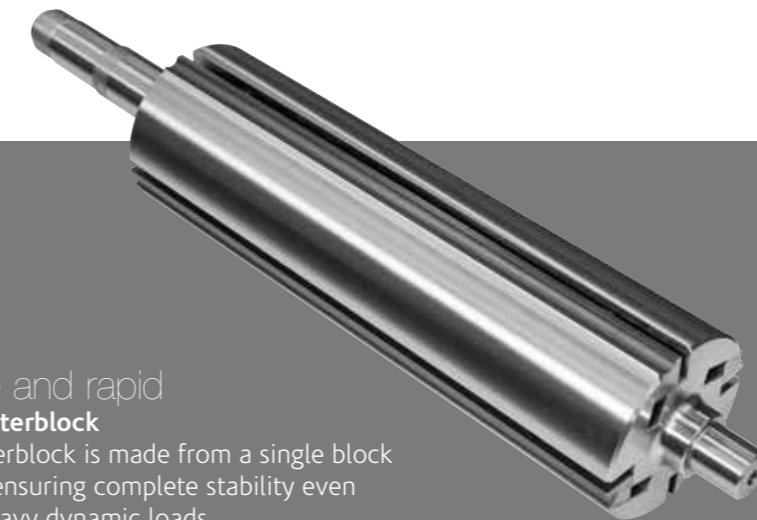

simple and rapid  
**SCM cutterblock**  
The cutterblock is made from a single block of steel ensuring complete stability even under heavy dynamic loads.

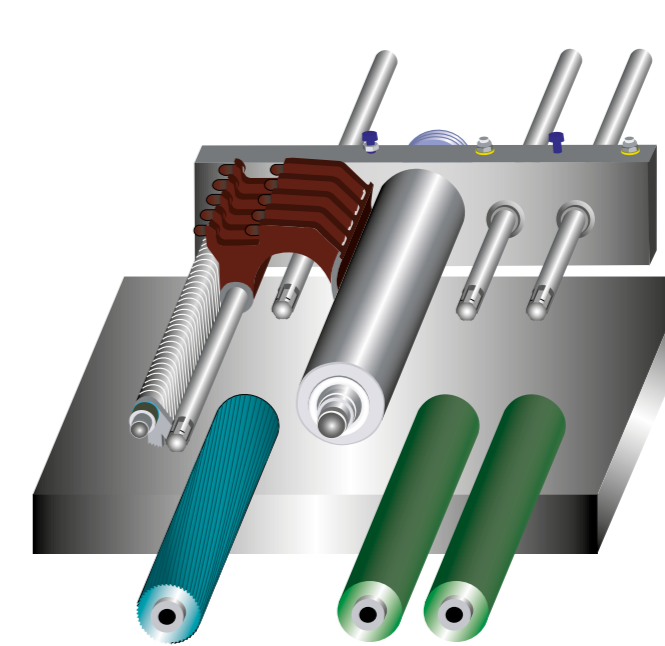

solutions for every requirement  
**Interchangeable rollers**  
**Perfect finish obtained by quick and easy changeover of the rollers** that allows the operator to configure the machine drive function in case of special requirements, such as a minimum removal of fine wood and/or batches where multiple pieces of different thicknesses are processed.  
*(third powered roller available as option)*

Powered worktable lifting with micrometric adjustment.

The 4 screws with a large diameter combined with the 2 side linear guides ensure worktable stability. The integrated protections guarantee high precision and reliability over time.



# planers main optional devices



## "Xylent" spiralknife cutterblock

The 3 spiralknives give an exceptional finish.

**Reduced noise** during machining provides a more comfortable working environment.

It also improves the dust extraction due to the **production of very small chips**.

Each cutter has 4 tips which can be rotated into the cutting position when worn.

Therefore, increasing the production life of the cutter block **before knives** require replacement.



## Maintenance case for "Xylent" spiralknife cutterblock

It includes:

- 1 cleaning/degreasing liquid bottle for the resins cleaning
- 1 set dynamometric key
- 2 bit Torx
- 10 inserts
- 5 screws
- 1 brass bristle brush to clean the spindle with mounted in inserts
- 1 steel bristle brush to clean the inserts housings



## Thickening table extension to be used in infeed or outfeed

It can be installed on the worktable end side.



## Additional overturning fence

Integrated in the surface fence, it ensures perfect operator safety when machining small dimensioned work-pieces.



## Cast-iron mortiser

Drilling holes and mortises are easily carried out. It includes the exhaust hood, 120 mm diameter and 16 mm chuck.



## Thickening table with idle rollers

It enables the feeding of moist and/or resinous wood. Particularly suitable for heavy duty woodworking operations and with rough work-pieces.



## Sectioned steel roller

It allows the simultaneous processing of different thicknesses giving great results even with minimum removal.



## Outfeed rollers in sandblasted steel

For a perfect post-processing finish.



## "Tersa" monoblock cutterblock

The cutterblock is made from a single block of steel ensuring complete stability even under heavy dynamic loads. Automatic knives clamping by means of the centrifugal force ensures safe and precise machining. The system, without fixing screws, makes knives substitution extremely fast.

# planers technical data

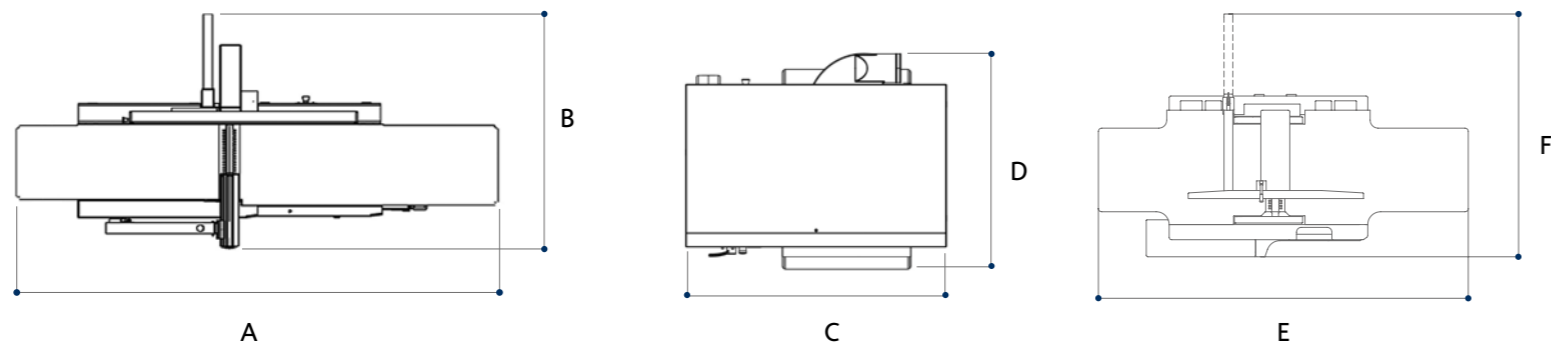

S Standard  
O Option

TECHNICAL DATA		nova f 520	nova f 410	nova s 630	nova s 520	nova fs 520	nova fs 410
Working width	mm	520	410	630	520	520	410
Cutterblock diameter/standard knives	mm/n.	120/4	120/4	120/4	120/4	120/4	95/4
Standard knives dimensions	mm	35 x 3 x 520	35 x 3 x 410	35 x 3 x 640	35 x 3 x 520	30 x 3 x 520	30 x 3 x 410
Max. stock removal	mm	8	8	8	8	5	5
Total worktable length	mm	2750	2610	-	-	2250	2200
Thicknessing table dimensions	mm	-	-	640 x 1000	530 x 900	520 x 850	410 x 775
Feed speed on thicknesser	m/min	-	-	5/8/12/18	5/8/12/18	5/8/12/18	6/12
Min. ÷ max. working height on thicknesser	mm	-	-	3,5 ÷ 300	3,5 ÷ 300	3,5 ÷ 240	3,5 ÷ 240
<b>other technical features</b>							
Three-phase motors 5 kW (6,6 hp) 50 Hz - 6 kW (8 hp) 60 Hz		S	S	-	S	-	S
Three-phase motors 7 kW (9,5 hp) 50 Hz - 8 kW (11 hp) 60 Hz		O	O	S	O	S	O
Three-phase motor 9 kW (12 hp) 50 Hz - 11 kW (15 hp) 60 Hz		-	-	O	-	O	-
Exhaust hood diameter	mm	120	120	150	150	120	120

OVERALL DIMENSIONS		nova f 520	nova f 410	nova s 630	nova s 520	nova fs 520	nova fs 410
A	mm	2750	2610	-	-	-	-
B	mm	1415	1150	-	-	-	-
C	mm	-	-	1275	1140	-	-
D	mm	-	-	1080	1003	-	-
E	mm	-	-	-	-	2250	2200
F	mm	-	-	-	-	1510	1200

MAIN OPTIONAL DEVICES	nova f 520	nova f 410	nova s 630	nova s 520	nova fs 520	nova fs 410
"Tersa" monoblock cutterblock	O	O	O	O	O	O
"Xylent" spiralknife cutterblock with 3 spiralknives	O	O	O	O	O	O
Maintenance case for "Xylent" spiralknife cutterblock	O	O	O	O	O	O
Additional overturning fence for the processing of thin work-pieces	O	O	-	-	O	O
Worktable with 2 idle rollers	-	-	O	O	O	-
First front sectioned steel roller in place of the grooved one	-	-	O	O	-	-
Outfeed steel rollers in place of the rubber-coated ones	-	-	O	O	-	-
Powered thicknessing table lifting with micrometric movement	-	-	S	S	O	O
Cast-iron mortiser	-	-	-	-	O	O
Thicknessing table extension to be used in infeed or outfeed	-	-	O	O	O	-

spindle moulders  
 nova tf 110  
 nova ti 105  
 nova tf 100



		nova tf 110	nova ti 105	nova tf 100
Spindle height CE Ø 30-35 (40-50)	mm	140 (180)	125 (125)	125 (125)
Max. diameter of the profiling tool	mm	250	240	240
Max. tool diameter retractable under worktable at 90°	mm	320	240	240
Max. diameter of tenoning tool CE Ø 30-35 (40-50)	mm	300 (350)	275 (320)	240 (240)
Three-phase motors power starting from	kW/Hz	5 (6) / 50 (60)	5 (6) / 50 (60)	5 (6) / 50 (60)

Find the complete technical specification at page 44



Spindle Moulder Unit  
 sturdiness and versatility



Spindle Moulder Fence  
 set-up rapidity



Machine Versions  
 specialisation and professionalism

Precision and reliability in unbeatable time.

# spindle moulder operating groups



## nova ti 105 optional electronic controls



Powered operating unit movement with digital readouts  
Maximum precision and ease-of-use.

### sturdiness and versatility

#### Spindle moulder unit

Maximum stability and rigidity in all working conditions, thanks to a large spindle moulder column made entirely of cast iron. The spindle is surrounded by a cast iron "cup" to protect the internal mechanical components from shavings and sawdust. The 5 standard speed (4 speed for *nova ti 105* and *nova tf 100*) are ideal for any type of machining, from profiling to moulding and tenoning, with the possibility to fit large diameter tools.

### "Flex One" spindle moulder fence Automatic adjustment of the entire fence according to the tool diameter.

The "Flex" exclusion system (SCM solution) is user-friendly with precise re-positioning.



### Ready 3 UP

The programming of the work becomes simple and effective with the electronic mobile control panel with a 4" LCD colour screen. Working mode: manual, semi-automatic and automatic with a memory capacity of up to 99 programs.

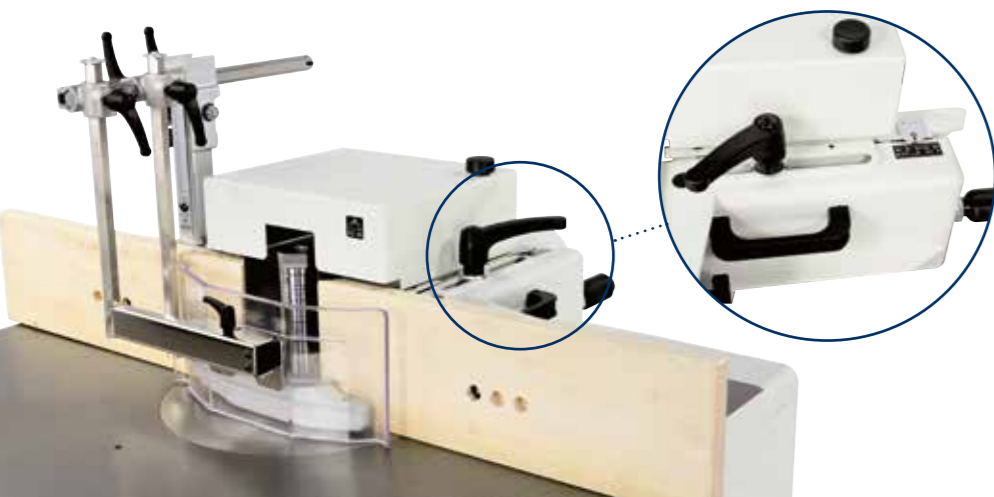

### easy to use

#### Adjustable spindle moulder fence

A handle provides the setting-up of the infeed table, which effects the removal and it is verified by an index on a metric scale.



Tool-holder shaft lifting



Tool-holder shaft tilting



Adjustment of the entire profiling fence



Tool-holder shaft speed readout

# spindle moulder machine versions

For the profiling of very large work-pieces, the *nova ti 105* can be equipped with a **support frame complete with two reversible stops**.

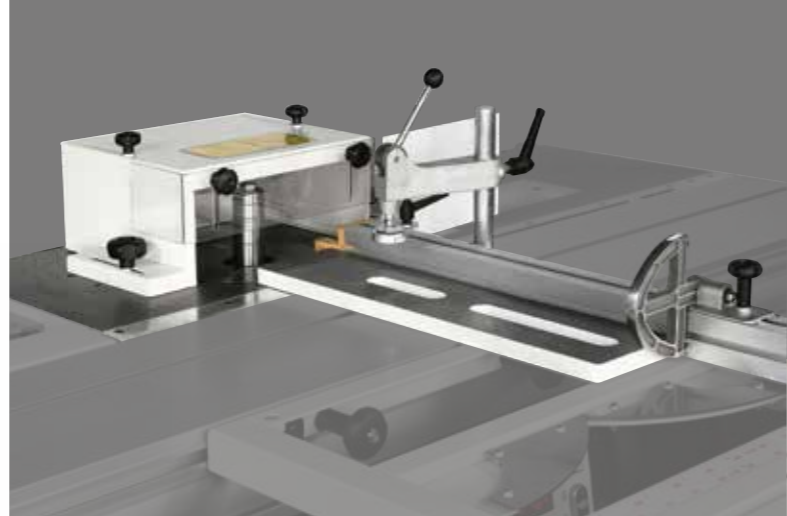

**Carriage on worktable for small tenoning operations**  
Ideal for tenoning of small work-pieces for the versions without sliding carriage. Mitre cuts with angles of  $\pm 60^\circ$  on the worktable are possible. Easy fitting and removal due to the fixing system on the worktable.

The *nova ti 105* "version with front sliding carriage" can be equipped with **tenoning table and tenoning hood** in order to house tools, 320 mm max. diameter (300 mm USA/ Canada).



**"TL" versions**  
Top machining precision and stability due to the manual feed carriage with castiron structure mounted on axial bearings running on slideways made from hardened and ground bar.

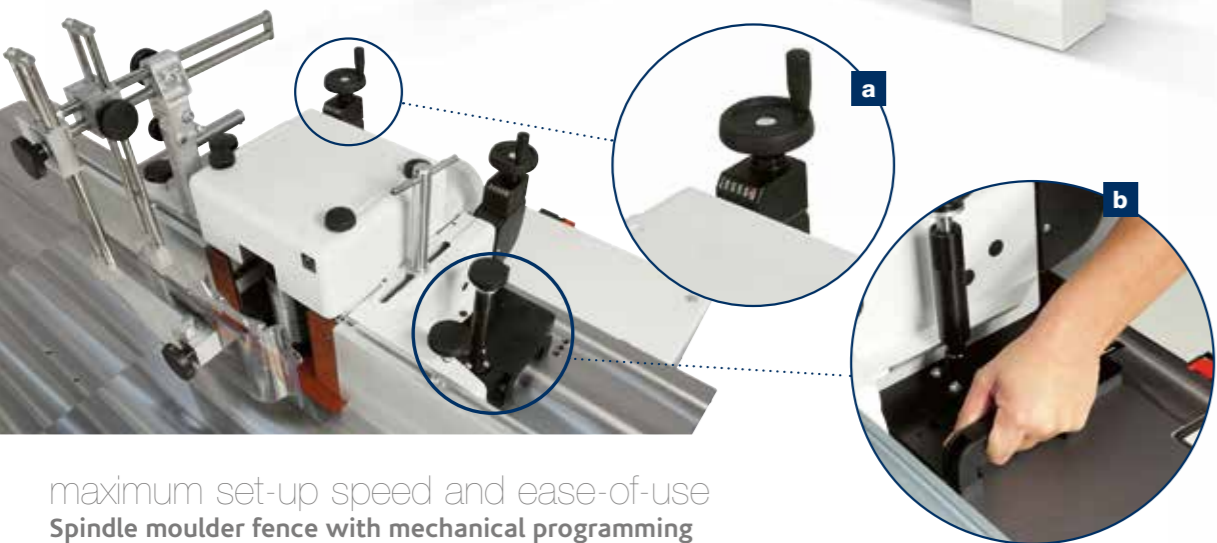

maximum set-up speed and ease-of-use

## Spindle moulder fence with mechanical programming

No more test runs due to digital readouts **(a)** that ensure accuracy to a tenth of a millimetre in positioning the two worktables. The side handles **(b)** make it easy to remove and reposition the fence from the worktable.



**"LL" versions with worktable side extensions**  
Ideal when machining very long work-pieces due to worktable extensions. The mobile front bar makes it easy to move large dimensioned work-pieces on the worktable, particularly for edge profiling.

For a total safety and a higher flexibility, the machine is supplied, as standard feature, with a **special protection hood for moulding operations**.

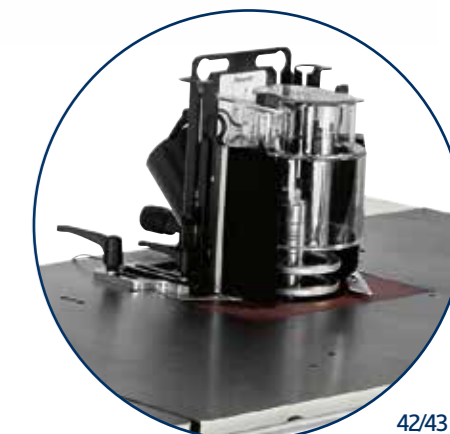

# spindle moulder technical data

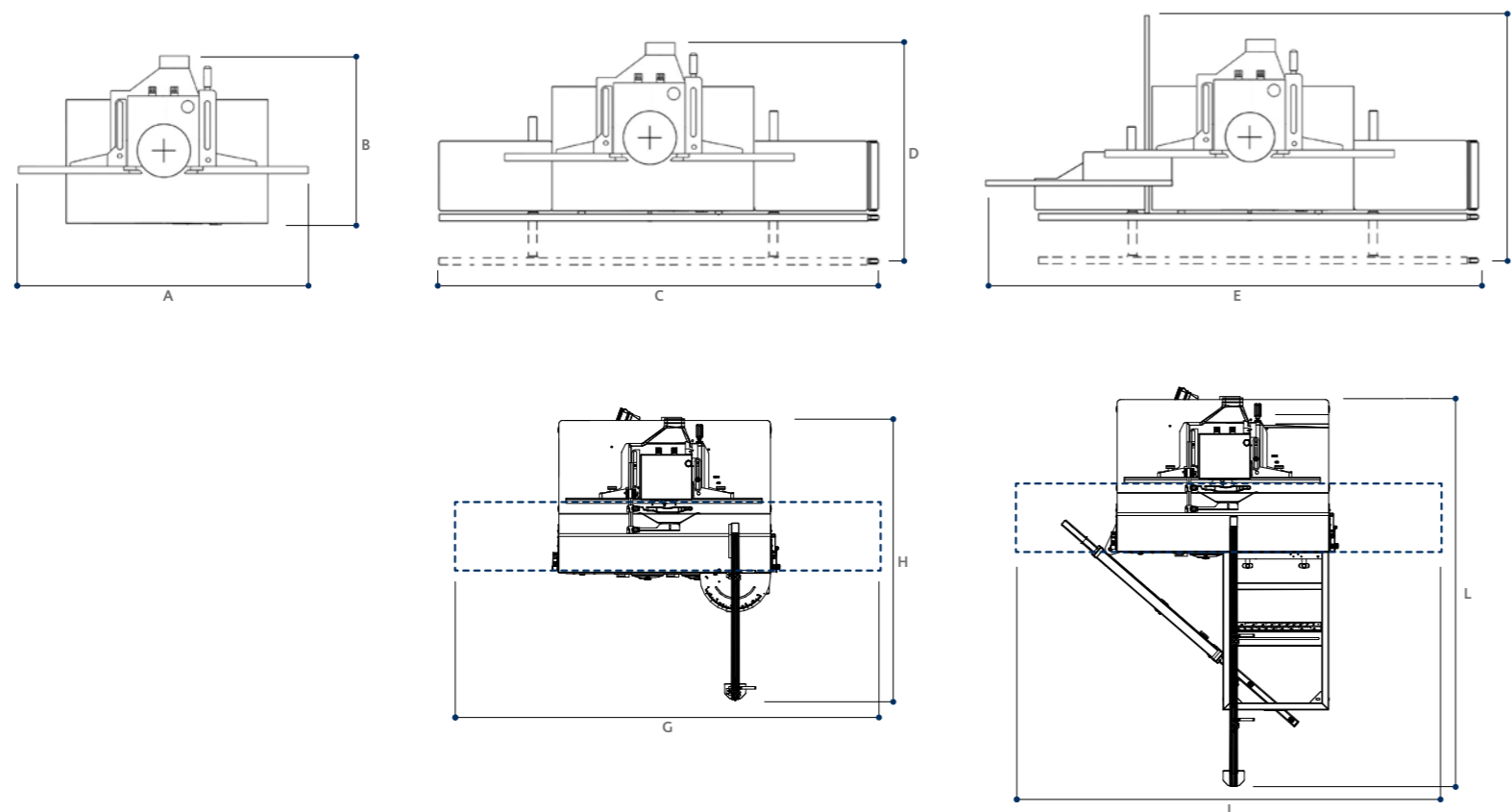

S Standard  
O Option

TECHNICAL DATA		nova tf 110	nova ti 105	nova tf 100
Worktable dimensions	mm	1200 x 730	1200 x 855	1080 x 655
Spindle tilting		-	0° ÷ +45°	-
Spindle height CE Ø 30-35 (40-50)	mm	140 (180)	125 (125)	125 (125)
Spindle speed (at 50 Hz)	rpm	3000/4500/6000/7000/10.000	3500/6000/8000/10.000	3500/6000/8000/10.000
Max. diameter of the profiling tool	mm	250	240	240
Max. tool diameter retractable under worktable at 90°	mm	320	240	240
Max. diameter of tenoning tool CE Ø 30-35 (40-50)	mm	300 (350)	275 (320)	240 (240)
<b>other technical features</b>				
Three-phase motors 5 kW (6,6 hp) 50 Hz - 6 kW (8 hp) 60 Hz		S	S	S
Three-phase motors 7 kW (9,5 hp) 50 Hz - 8 kW (11 hp) 60 Hz		O	O	O
Exhaust hood diameter:				
- at the base	mm	120	120	120
- on the spindle moulder fence	mm	120	120	120

## OVERALL DIMENSIONS

		nova tf 110	nova ti 105	nova tf 100
A	mm	1200	1200	1111
B	mm	730	855	655
C	mm	2600	2600	2600
D min.	mm	800	920	720
D max.	mm	1250	1220	1020
E	mm	3150	-	-
F min.	mm	800	-	-
F max.	mm	1250	-	-
G	mm	-	2800 ÷ 3850	-
H	mm	-	2354	-
I	mm	-	2800 ÷ 3850	-
L	mm	-	3200	-

## MAIN OPTIONAL DEVICES

	nova tf 110	nova ti 105	nova tf 100
"Ready 3 UP" version with "Flex One" spindle moulder fence	-	O	-
Support frame with tiltable telescopic fence complete with 2 reversible stops	-	O	-
Powered operating unit movement with digital readouts	-	O	-
Spindle moulder fence with mechanical programming	O	O	O
Aluminium tabled instead of the wooden ones for profiling fence	O	O	O
Interchangeable spindle	O	O	O
Spindle for router bits	O	O	O
"LL" version with 2 cast-iron profiling extensions	O	O	O
"TL" version for tenoning and profiling	O	-	-
Tenoning table and tenoning hood	-	O	-
Carriage on the fixed table for small tenoning operations	O	O	O

# PROMPT AND EXPERT TECHNICAL SUPPORT THROUGH A NETWORK OF 1000 TECHNICIANS AND AN INVENTORY OF 36,000 SPARE PARTS.

HIGHLY SPECIALISED TECHNICIANS, EFFICIENT MANAGEMENT AND 6 SPARE PARTS BRANCHES AROUND THE WORLD GUARANTEE A CLOSE, SAFE AND EFFECTIVE TECHNICAL SUPPORT.

## SERVICE

SCM provides a service that goes beyond the purchase, to guarantee the long term performance of your technological production system and peace of mind for your business.

### A COMPLETE RANGE OF AFTER-SALES SERVICES

- installation and start-up of machines, cells, lines and systems
- tailored training programs
- telephone support to reduce times and costs when machines are not working
- preventive maintenance programs to guarantee long term performance
- complete renovation of machines and plants to renew the added value of the investments
- custom upgrading to update machines and plants and meet new production requirements



## SPARE PARTS

SCM Group can count on 140 spare parts professionals worldwide to meet any request with real time shipments.



### 36,000 SPARE PARTS

Our spare parts inventory, with a value of 12 million euros, covers every single machine



### SPARE PARTS GUARANTEED

We guarantee also hard to find parts, with 3,5 million euros invested in "critical" spare parts.



### IMMEDIATE AVAILABILITY

Over 90% of orders received are carried out the same day thanks to the huge inventory available.



### 6 BRANCHES AROUND THE WORLD

The spare parts service can count on worldwide support (Rimini, Singapore, Shenzhen, Moscow, Atlanta, São Bento do Sul)



### 500 SHIPMENTS A DAY



# THE STRONGEST WOOD TECHNOLOGIES ARE IN OUR DNA

## SCM. A HERITAGE OF SKILLS IN A UNIQUE BRAND

Over 65 years of success gives SCM the centre stage in woodworking technology. This heritage results from bringing together the best know-how in machining and systems for wood-based manufacturing. SCM is present all over the world, brought to you by the widest distribution network in the industry.

- 65+ years history
- 3 main production sites in Italy
- 300.000 square metres of production space
- 20.000 machines manufactured per year
- 90% export
- 20 foreign branches
- 400 agents and dealers
- 500 support technicians
- 500 registered patents



In SCM's DNA also strength and solidity of a great Group. The SCM Group is a world leader, manufacturing industrial equipment and components for machining the widest range of materials.

## SCM GROUP, A HIGHLY SKILLED TEAM EXPERT IN INDUSTRIAL MACHINES AND COMPONENTS

### INDUSTRIAL MACHINERY

Stand-alone machines, integrated systems and services dedicated to processing a wide range of materials.



WOODWORKING TECHNOLOGIES



TECHNOLOGIES FOR PROCESSING COMPOSITE MATERIALS, ALUMINIUM, PLASTIC, GLASS, STONE, METAL

### INDUSTRIAL COMPONENTS

Technological components for the Group's machines and systems, for those of third-parties and the machinery industry.



SPINDLES AND TECHNOLOGICAL COMPONENTS



ELECTRIC PANELS



METALWORK



CAST IRON



# Vrtací dlabačka **HD 230**



Zdeněk Kejzlar a Libor Holý  
**HOK – KOVOVÝROBA**  
Horní Kostelec  
549 41 Červený Kostelec

Tel : +420 491 461 196  
Fax : +420 491 463 573  
[www.hok.nc@tiscali.cz](http://www.hok.nc@tiscali.cz)

**Zdeněk Kejzlar**  
+420 776 586 647

**Libor Holý**  
+420 603 229 196

**V á ž e n ý   z á k a z n í k u ,**

stal jste se majitelem Vrtací dlabačky HD 230. Máme zájem na tom, abyste byl s naším výrobkem spokojen a aby se Vám se strojem co nejlépe pracovalo.

**Výroba probíhá se schválením firmy G & M – POINT dle schválené výrobní dokumentace.**

Bezchybný provoz stroje vyžaduje odbornou manipulaci a dobrou údržbu. Žádáme Vás proto, abyste si ve vlastním zájmu pečlivě prostudoval Technickou dokumentaci a Návod pro obsluhu Dodržováním návodu pro obsluhu si ušetříte starosti při případné poruše stroje způsobené špatným a neodborným zacházením.

Naše firma Vám přeje úspěšnou práci na našem stroji a zároveň i nejlepší výsledky.

## Vrtací dlabačka HD 230

### Obsah

1	Značky a značení	4 str.
1.1	Bezpečnostní značení na stroji	4 str.
1.2	Bezpečnostní značení v návodu	4 str.
2	Všeobecné údaje o stroji	4 str.
2.1	Určení stroje	4 str.
2.2	Technický popis stroje	5 str.
2.3	Provedení stroje	6 str.
2.4	Technická data stroje	7 str.
2.5	Montáž a doprava stroje	7 str.
2.6	Připojení stroje na el. síť	8 str.
3	Uvedení stroje do trvalého provozu	8 str.
3.1	Ustavení stroje na pracovní místo	8 str.
3.2	Ovládání stroje	8 str.
4	Údržba stroje	10 str.
4.1	Provádění údržby stroje	10 str.
4.2	Mazání stroje	11 str.
5	Hlučnost stroje	11 str.
6	Bezpečnostní předpisy	11 str.
6.1	Bezpečnostní pokyny	12 str.
6.2	Bezpečný pracovní postup	12 str.
7	Zvláštní příslušenství	12 str.
7.1	Kolíkovací zařízení	12 str.
7.2	Upínací úhelník	12 str.
8	Elektroschema stroje	13 str.
9	Záruční podmínky a obchodní služby	14 str.
9.1	Záruční podmínky	14 str.
9.2	Obchodní služby	14 str.

## 1 Značky a značení

### 1.1 Bezpečnostní značení na stroji

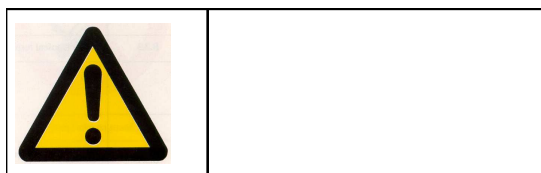

Umístění  
Kryt vrtacího nástroje

**POZOR !!!**  
Hrozí nebezpečí odření prstů nástrojem

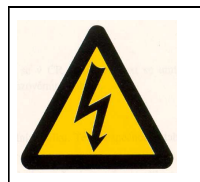

na čelní části  
stroje)

Umístění

Přívodní skříňka elektrického proudu  
stroje (oblast zapínání a vypínání

### 1.2 Bezpečnostní značení v návodu



**Pozor!** Nedodržení tohoto požadavku ohrožuje bezpečnost

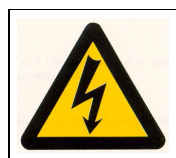

**Pozor!** Nedodržení tohoto požadavku může způsobit úraz elektrickým proudem

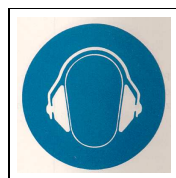

**Pozor!** Při práci na vrtací dlebačce hrozí poškození sluchových orgánů.

## 2 Všeobecné údaje o stroji

### 2.1 Určení stroje

Horizontální vrtací a dlebačící stroj HD 230 jeho odvozená varianta HD 230 R je určena pro vyvrtávání otvorů a provádění zádlabů. Pro svoji robustnost a jednoduché ovládaní je určen pro práci v malých až středně velkých provozech zabývající se výrobou nábytku. Po doplnění kolíkovací lištou lze vrtat otvory pro dřevěné kolíky v požadované přesnosti.

Horizontální vrtací a dlebačící stroj HD 230 jeho odvozená varianta HD 230 R jsou schopny bezpečně vykonávat svoji funkci v prostředí s nebezpečím požáru hořlavých hmot – BE2N1 podle ČSN 33 2000-3:1995 ( eqv.HD 384.3 S2.1995 ).

## 2.2 Technický popis stroje.

Stojan stroje je svařen z ocelového plechu. V horní části stojanu je umístěno posuvové vedení, na kterém je připevněn elektromotor. Na přírubě motoru je provedeno uložení pro další ložisko 6207, které s původním ložiskem motoru zajišťuje zvýšenou pevnost uložení sklíčidla.

Jako sklíčidlo je použito univerzální sklíčidlo průměr 80 mm připevněné na zvláštní přírubě. Toto sklíčidlo je zakryté odklápěcím ocelovým krytem s vyznačeným směrem otáčení. Vrtací hlava se posouvá do záběru pomocí ruční páky, spojené s deskou suportu. Hloubku vrtaného otvoru lze nastavit pomocí narážky umístěné na pomocné tyči umístěné pod posuvným stolem.

V přední části stojanu je upevněno těleso pracovního stolu s vertikálním vodícím pouzdrům na němž je uloženo vedení pracovního stolu a kompletní pracovní deska. Zdvih pracovního stolu se provádí pomocí ručního litinového kola se stoupáním 4 mm.otáčka<sup>-1</sup>. Poloha stolu se aretuje proti samovolnému posunu aretačním šroubem. Upínací zařízení je připevněno na tyči upevněné v nálitku pracovního stolu.

Horizontální posuv je ovládán pomocí ruční páky spojené s pracovním stolem ojnicí.

Elektrická část se skládá z motorového ochranné spínače typu MS 4 ( 2,5 až 4A ) doplněného podpětovou cívkou. Spínač včetně podpětové cívky je instalován v izolačním krytu ( třída II ) a je uzamykatelný. Pro pohon vrtací dlebačky je použit třífázový asynchronní elektromotor o výkonu 1,5 kW. Připojení stroje k síti je pevně připojeným pohyblivým přívodem 4x1,5 –CYSY s pětipólovou vidlicí - typ 016, 16 A /400V, IP 44.

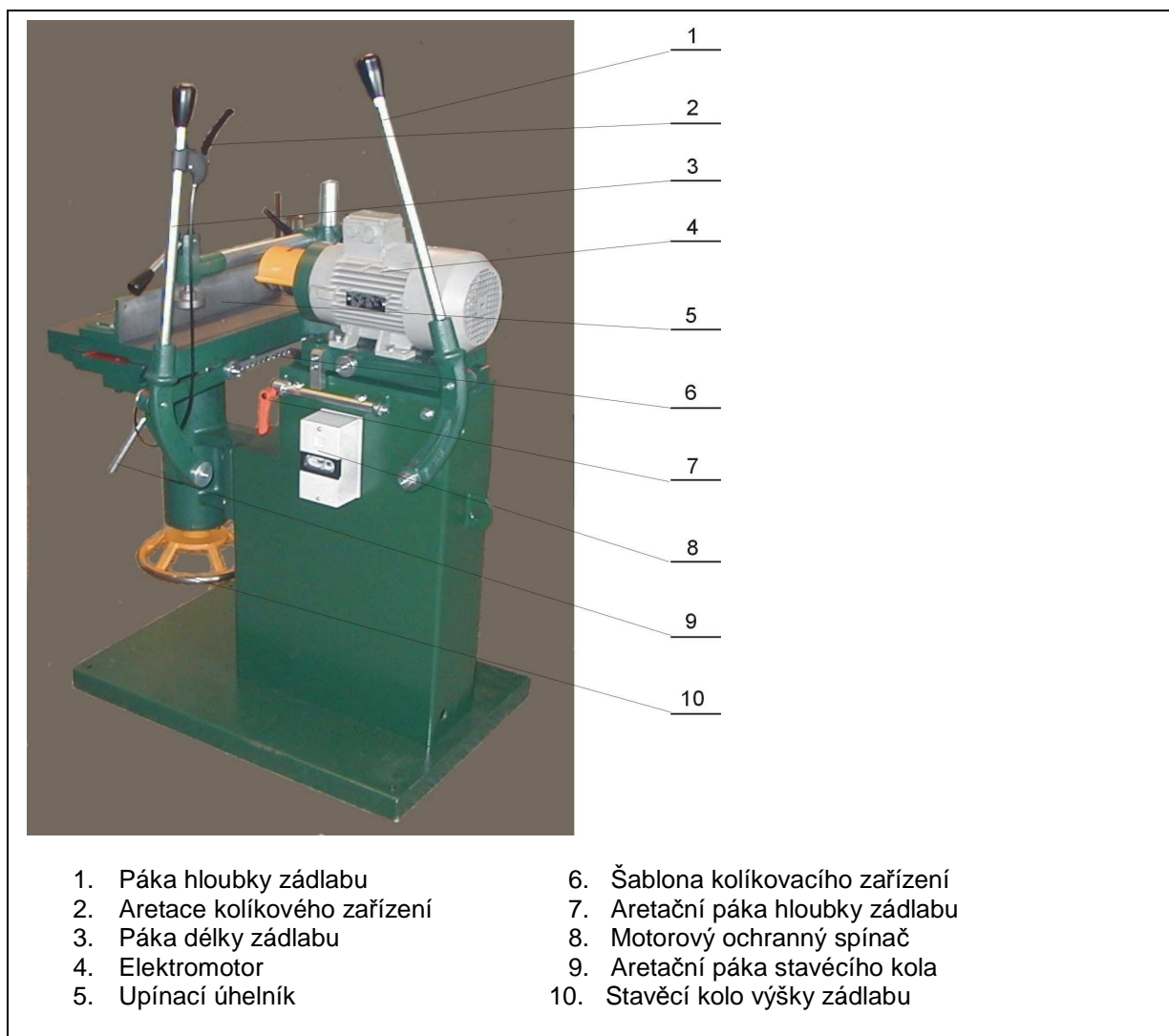

### 2.3 Provedení stroje

Stroj byl konstruován s přihlédnutím k normám a předpisům platným na území ČR a EU.

- NV 24/2003 Sb.
- NV č.17/2003 Sb., kterým se stanoví technické požadavky na elektrická zařízení nízkého napětí
- NV č.18/2003 Sb., kterým se stanoví technické požadavky na výrobky z hlediska jejich elektromagnetické kompatibility
  
- Směrnice Rady 73/23/EHS naposledy pozměněné směrnicí Rady 93/68/EHS, kterým se stanoví technické požadavky na elektrické zařízení nízkého napětí
- Směrnice Rady 89/336/EHS naposledy pozměněné směrnicí Rady 93/68/EHS, kterým se stanoví technické požadavky na výrobky z hlediska jejich elektromagnetické kompatibility
- Směrnice Evropského parlamentu a Rady 98/37/ES naposledy pozměněné směrnicí Evropského parlamentu a Rady 98/79/ES, kterým se stanoví technické požadavky na strojní zařízení

#### Použité normy a předpisy:

ČSN EN 292-1:2000 Bezpečnost strojních zařízení. Základní pojmy, všeobecné zásady pro projektování. Část 1. Základní terminologie, metodologie.

ČSN EN 292-2+A1:2000 Bezpečnost strojních zařízení. Základní pojmy, všeobecné zásady pro projektování. Část 2. Technické zásady a specifikace.

ČSN 49 6120:1988 Dřevozpracující zařízení. Vrtačky a vrtací dlabačky. Bezpečnostní požadavky na konstrukci

ČSN EN 614-1:1997 Bezpečnost strojních zařízení. Ergonomické zásady pro projektování. Část 1: Terminologie a všeobecné zásady.

ČSN EN 953:1998 Bezpečnost strojních zařízení. Ochranné kryty. Všeobecné požadavky pro konstrukci a výrobu pevných a pohyblivých ochranných krytů.

ČSN ISO 7000:1994 Grafické značky nahrazující nápisy na zařízeních. Rejstřík a přehled značek.

ČSN ISO 3864 :1995 Bezpečnostní barvy a bezpečnostní značky

ČSN ISO 3746:1996 Akustika. Určení hladin akustického výkonu zdrojů hluku pomocí akustického tlaku. Provozní metoda měření ve volném poli nad odrazovou rovinou.

ČSN ISO 7960:1997 Hluk vyzařovaný obráběcími stroji, šířený vzduchem. Provozní podmínky pro dřevoobráběcí stroje.

ČSN EN ISO 11202:1997 Akustika. Hluk vyzařovaný stroji a zařízeními. Měření akustického tlaku na stanovišti obsluhy a dalších místech. Provozní metoda in situ.

ČSN EN 60204-1:2000 - Bezpečnost strojních zařízení. Elektrická zařízení strojů. Část 1: Všeobecné požadavky.

ČSN EN 61000-6-4:2002 Elektromagnetická kompatibilita ( EMC ) – část :6-4: Kmenové normy - Emise – Průmyslové prostředí

ČSN EN 61000-6-2:2002 Elektromagnetická kompatibilita ( EMC ) – část :6-2: Kmenové normy - Odolnost pro průmyslové prostředí

## 2.4 Technická data stroje

Rozměry stroje		
délka	750	mm
šířka	500	mm
výška	1250	mm
Váha stroje		
	200	kg
Rozm. prac. stolu		
délka	460	mm
šířka	300	mm
Elektromotor		
otáčky	2800	ot.min-1
výkon	1,5	kW
Hlučnost		
akustický výkon L <sub>Pa</sub> (A)	95	dB (A)
hladina hluku na prac. místě L <sub>a</sub> (A)	85	dB (A)
Jmenovité napětí 3/PE AC 400V		
Jmenovitý kmitočet	50	Hz
Jmenovitý proud	3,3	A
Stupeň krytí		
elektromotor a motorový ochranný spínač	IP 55	
vidlice	IP 44	
Teplota okolí	+5 °C až + 40 °C	
Relativní vlhkost	nepřekračující 50% při nejvyšší teplotě + 40 °C	
Nadmořská výška	1000	do m

## 2.5 Montáž, doprava a skladování stroje



Stroj je přepravován ve smontovaném stavu. Dodávaný stroj je při přepravě dodáván v dřevěném latění. Proti povětrnostním vlivům je zabalen ve folii z PVC.

Vzhledem ke konstrukci stroje není bezpodmínečně nutno stroj kotvit na předem vybudovaný předepsaný základ. Ukotvení stroje je však výhodné pro zvětšení jeho stability. Kotvený stroj je nutné vyrovnat do roviny s přesností 1mm/1m.

Před zahájením práce na neukotveném stroji je nutné provést vyrovnání stroje se stejnou přesností.

Stroj je nutné při přepravě upínat na vyznačených vázacích místech.

Elektrické zařízení je navrženo tak, aby odolávalo teplotám při přepravě a skladování v rozsahu od – 25 °C do +55 °C a po krátkou dobu nepřekračující 24 h, teplotě do + 70 °C.

Musí být učiněna vhodná opatření aby se předešlo poškození vlhkem , vibracemi a otřesy.

## 2.6 Připojení stroje na el. síť



Přívodní el. instalace musí být provedena dle platných předpisů a požadavků příslušných ČSN. Připojovací zásuvka s připojeným ochranným vodičem musí být jističena jističem nebo pojistkami 16 A.

## 3 Uvedení stroje do trvalého provozu



### 3.1 Ustavení stroje na pracovní místo

Vzhledem ke konstrukci stroje není bezpodmínečně nutno stroj kotvit na předem vybudovaný předepsaný základ. Ukotvení stroje je však výhodné pro zvětšení jeho stability. Kotvený stroj je nutné vyrovnat do roviny s přesností 1mm/1m.

Před zahájením práce na neukotveném stroji je nutné provést vyrovnání stroje se stejnou přesností.

Po ustavení stroje na pracovní místo je nutné zkontrolovat směr otáčení nástroje. Směr otáčení nástroje je na stroji vyznačen šipkou.

V případě opačného směru otáčení nástroje je nutné provést záměnu fázových vodičů.

**Záměnu fázových vodičů může provádět pouze osoba znalá (dle ČSN 34 3100, viz vyhláška č.: 50/78 Sb. ), nebo osoba s příslušnou elektrotechnickou kvalifikací podle norem platných v zemích určení.**

### 3.2 Ovládání stroje

#### Upevnění vrtáků

Vrták nasadíme do sklíčidla a řádně utáhneme. po utažení přiklopíme zpět ochranný kryt.

#### Zvedání a spouštění pracovního stolu



1. Aretační páka stavěcího kola
2. Stavěcí kolo výšky zádlabu

Stůl se zvedá a spouští otáčením ručního kola. Před změnou polohy stolu je nutné uvolnit aretační šroub. Po nastavení stolu do požadované výšky opět aretační šroub je nutno dotáhnout.

#### Seřízení vrtací hloubky

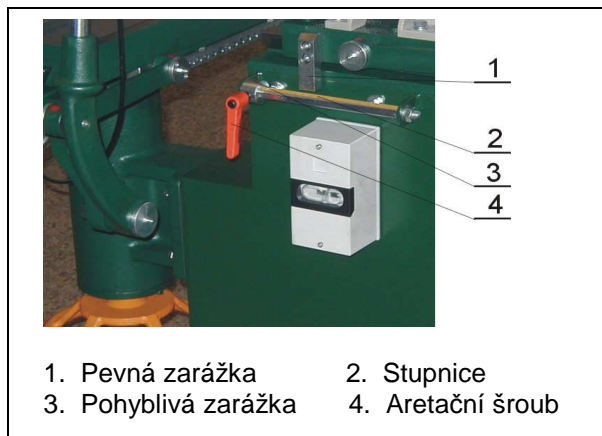

Vrtací hloubka se seřídí po uvolnění posuvného dorazu, který je umístěn pod suportem motoru. Ruční pákou posouváme suport s nástrojem na potřebnou vrtanou hloubku. Po najetí na potřebnou hloubku doraz pevně utáhneme.

- |                      |                   |
|----------------------|-------------------|
| 1. Pevná zarážka     | 2. Stupnice       |
| 3. Pohyblivá zarážka | 4. Aretační šroub |

### Seřízení frézovací šířky

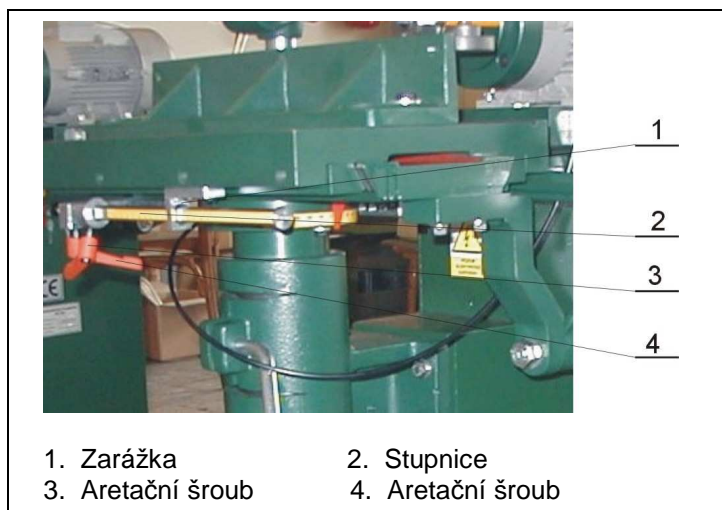

Frézovací šířku seřizujeme pomocí dvou dorazů umístěných na pracovním stole. Po povolení dorazů nastavíme potřebnou frézovací šířku a dorazy pevně utáhneme.

- |                   |                   |
|-------------------|-------------------|
| 1. Zarážka        | 2. Stupnice       |
| 3. Aretační šroub | 4. Aretační šroub |

### Spouštění a zastavování stroje

Spouštění se provede černým tlačítkem označeným START. Zastavení se provede červeným tlačítkem označeným STOP. Obě tlačítka jsou umístěna na motorovém ochranném spínači.

### Natáčení pracovního stolu

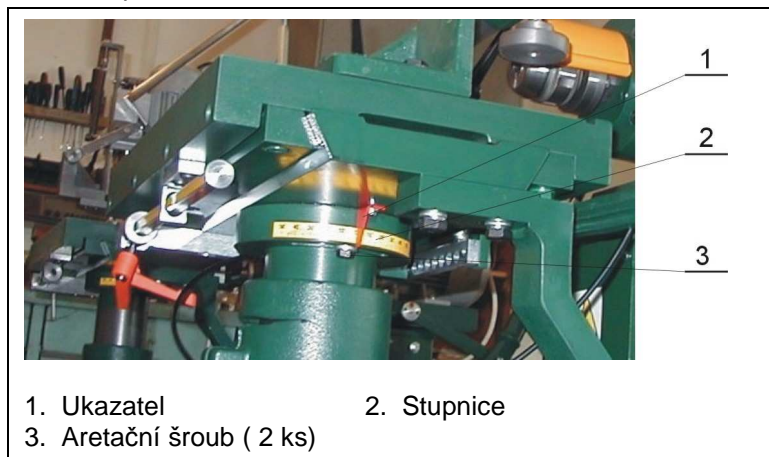

- |                           |             |
|---------------------------|-------------|
| 1. Ukazatel               | 2. Stupnice |
| 3. Aretační šroub ( 2 ks) |             |

## Ovládání stroje

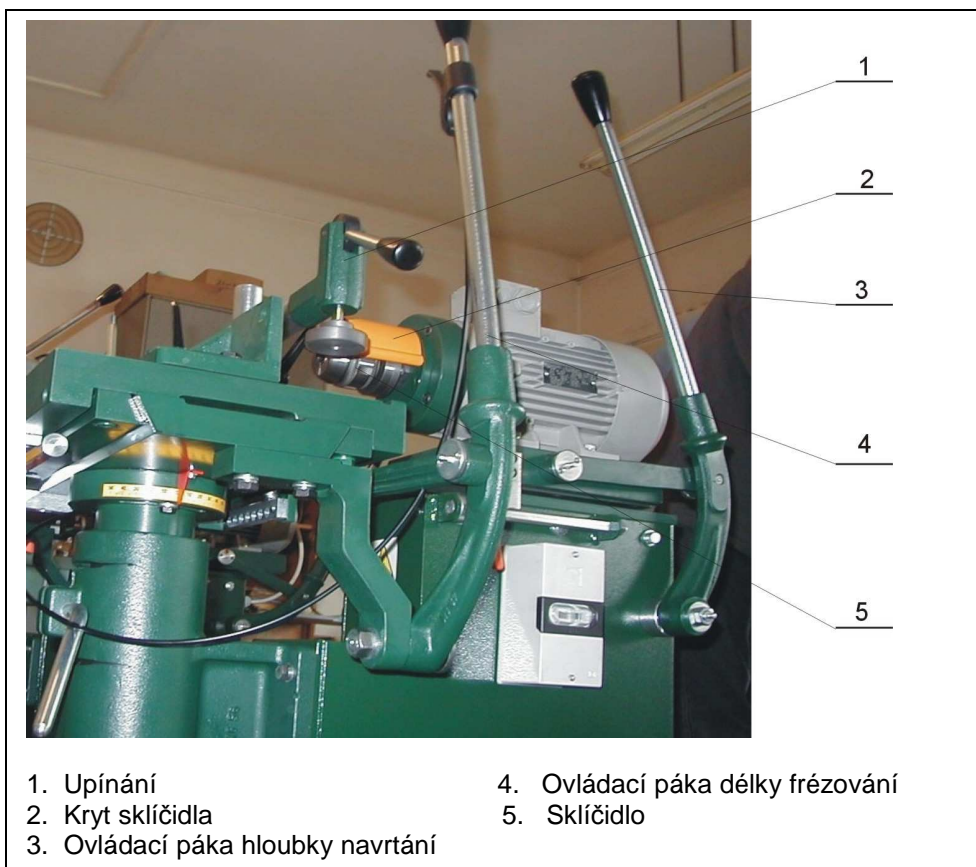

## 4 Údržba stroje

### 4.1 Provádění údržby stroje



Horizontální vrtací a dlabací stroj HD 230 (odvozená varianta HD 230 R) je stroj velmi jednoduché konstrukce, které nevyžadují žádné speciální údržbářské nebo opravárenské zákroky.

Stroj je nutné pravidelně čistit od prachu a dřevěných pilin. Čištění stroje provádějte nejméně po osmi provozních hodinách.

Zjistíte-li kmitání nástroje při provozu, je nutné znovu seřídit vůli mezi suportem motoru a vodítky. Po povolení upevňovacích šroubů vodítka jemně přitáhneme stavěcími šrouby. Vůli mezi vodítky a suportem měříme spárovými měrkami (správně seřízená vůle musí být 0,05 mm). Seřízený suport se musí pohybovat volně po celé délce zdvihu bez zadrhávání. Po seřízení vůle přitáhneme upevňovací šrouby a přeměříme vůli, po případě chybného nastavení znovu seřídíme.

Vůli v kloubech ručních pák vyměníme opotřebované dílce.

Údržba elektrických částí.

Pravidelně kontrolovat:

- neporušenost izolace síťového přívodu a spoje mezi elektromotorem a motorovým ochranným spínačem
- dotažení elektrických spojů – svorek
- funkci tlačítek START a STOP a podpěťové ochrany ( při výpadku elektrického napájení )

Údržba elektromotoru – podle pokynů výrobce elektromotoru – Siemens

### Upozornění:

Veškeré údržbářské a opravárenské úkony provádějte pouze na stroji odpojeném od el. sítě !

## 4.2 Mazání stroje

Na stroji nejsou žádná mazací místa, která by vyžadovala pravidelné mazání.

Ložiska použitého motoru je nutno po uplynutí 1000 provozních hodin demontovat, vyčistit a opatřit novou tukovou náplní. ( LITOL 24, LV 2-3 ).

Ložiska pákových mechanismů mažte tukovou náplní. ( LITOL 24, LV 2-3 ).

Kluzné plochy suportů (suport motoru a vedení pracovního stolu) a pohybového šroubu mažte olejem PP 90.

## 5 Hlučnost stroje

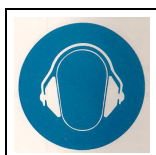

Hlučnost stroje			
		naměřené hodnoty	povolené hodnoty
Bez zatížení stroje technologií			
Akustický výkon stroje	L <sub>Pa</sub> v dB(A)	78	100
Hluk na pracovním místě	L <sub>a</sub> v dB(A)	64	90
Se zatížením stroje technologií			
Akustický výkon stroje	L <sub>Pa</sub> v dB(A)	90	100
Hluk na pracovním místě	L <sub>a</sub> v dB(A)	78	90

## 6 Bezpečnostní předpisy



### 6.1 Bezpečnostní pokyny

Okolí stroje musí být volně přístupné. Manipulaci s obráběným materiálem nesmí nic překážet.

Všechny úkony související s montáží a seřizením stroje je nutné provádět na stroji odpojeném od přívodu energie.

Na horizontálních vrtacím a dlabacím stroji HD 230 smí pracovat osoby starší 18-ti let řádně seznámeny s návodem k obsluze stroje a obsahem normy ČSN 49 6100 čl: 1P - 53P.

Osoby od 16 - 18 let mohou na stroji pracovat pouze v rámci učebního výcviku pod přímým dohledem odpovědné osoby.

Po ukončení práce musí obsluha zajistit stroj proti neoprávněnému použití – motorový ochranný spínač je v provedení – uzamykatelný visacím zámekem.

Při práci na stroji musí obsluha používat ochranná zařízení instalovaná výrobcem.

Pohyblivé části el. vedení musí být chráněny proti mechanickému poškození a nesmí tvořit překážku v pracovním nebo komunikačním prostoru.

## 6.2 Bezpečný pracovní postup

Dílec, který chceme zadlabávat položíme na pracovní stůl a připevníme úpinkami, které jsou součástí stroje.

Upneme dlabací vrták. Vrták nesmí být větší než je uvedeno v technických datech stroje.

Stavěcím kolem nastavíme určenou výšku zádlabu. Podkládání obráběného dílce je zakázáno.

Nastavíme hloubku a délku zádlabu.

Navrtáme potřebnou hloubku zádlabu. Vedle provedeného navrtání provedeme navrtání provedeme navrtání další a pokračujeme po celé nastavené délce.

Po navrtání celé délky ponoříme vrták do hloubky max. 10 mm a rozjedeme po celé délce. Tuto činnost provádíme do té doby než dosáhneme celé hloubky zádlabu.

## 7 Zvláštní příslušenství k vrtací dlabáčce HD 230

### 7.1 Kolíkovací zařízení

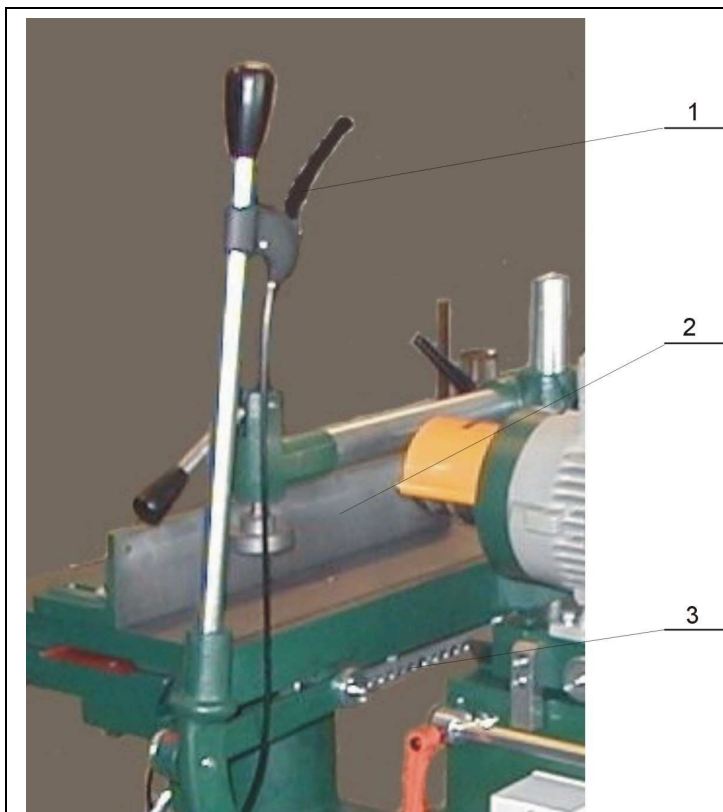

1. Páčka ovládání kolíkovacího zařízení
2. Upínací úhelník
3. Kolíkovací lišta (rozteč 16 mm)

Kolíkovací zařízení slouží k provádění otvorů pro spojování kolíky (kolíkování) desek, laťovek a dřevotřískových desek v délce 230 mm.

K přesnému vrtání otvorů slouží šablona s roztečí děr 16 mm (na přání zákazníka lze dodat s roztečí 32 mm) umístěná ve spodní části pracovního stolu. Do šablony zapadá broušený ocelový palec ovládaný pomocí páčky umístěné na ovládací páce posuvu pracovního stolu. Přenos přímočarého pohybu palce je proveden pomocí lanka umístěného v bovdenu.

Vyřazení kolíkovacího mechanismu z provozu provádíme tak, že palec vysuneme z kolíkovací lišty pomocí páčky a ve spodní části palec zaaretujeme šroubem M6, jehož konec zakončen křídlatou růžicí. Kolíkovací zařízení při objednání s vrtací dlabáčkou HD 230 je již přimontováno a seřizeno výrobcem.

## 7.2 Upínací úhelník

Upínací úhelník slouží k upínání vyšších dílců na stojato pro kolíkování a provádění zádlabů. K pracovnímu stolu se upíná pomocí 2 ks. šroubů M 10x40

## 8. Elektroschema stroje

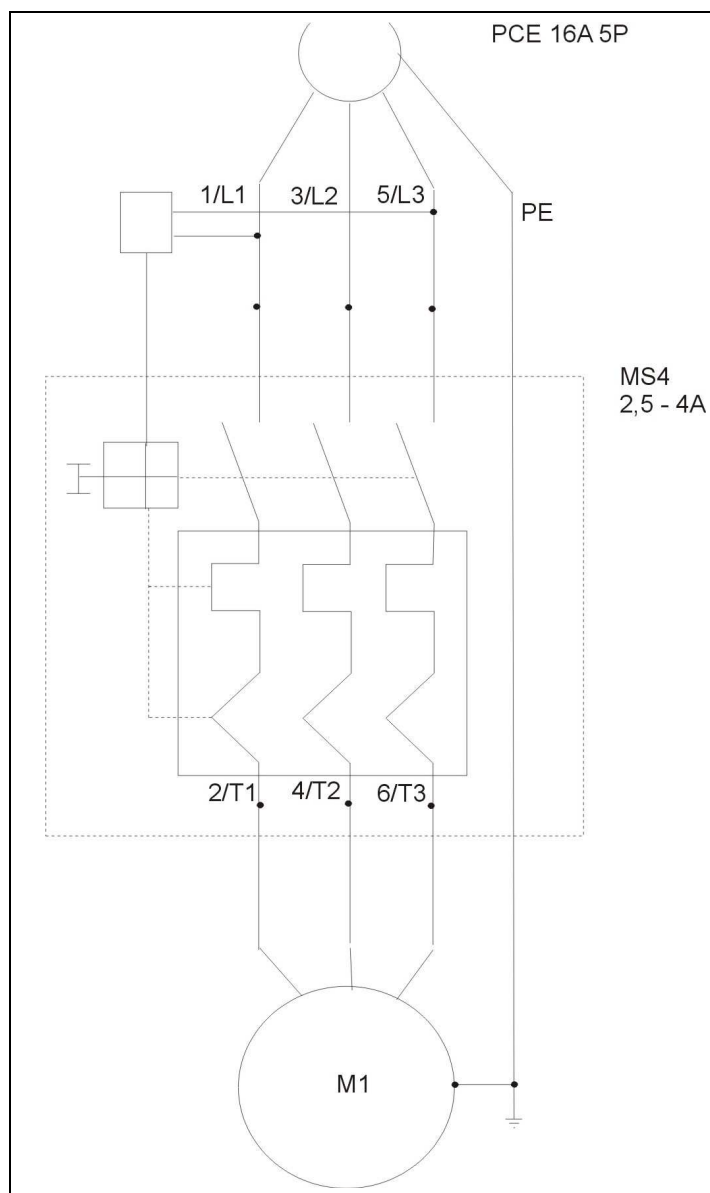

### Seznam elektrických součástí

- 1 Vidlice pětipólová PCE, typ 016, IP 44, 16 A / 400 V
- 2 Motorový ochranný spínač typ MS 4 ( 2,5 až 4 A ) s vestavěnou podpětovou ochrannou – 400V, 50 Hz, výrobce ABL SURSUM
- 3 Elektromotor – 3 ~ mot, typ 12A7090-2AA17, 1,5 kW , 50 Hz, 230 / 400 V, 5,65 / 3,25 A , IP 55, výrobce Siemens
- 4 Síťový přívod a propojovací kabel 4x1,5 CYSY

## **9 Záruční podmínky a obchodní služby**

### **9.1 Záruční podmínky**

Výrobní závod poskytuje na svůj výrobek záruční dobu 12 měsíců ode dne prodeje. V době záruky odstraní výrobní závod bezplatně všechny závady způsobené chybami ve výrobě nebo vadným materiálem.

Podmínkou pro uplatnění reklamace je správně vyplněný a potvrzený záruční list. Pro výměnu výrobku nebo zrušení kupní smlouvy platí příslušné ustanovení Občanského zákoníku a Obchodního zákoníku.

Záruka se nevztahuje na vady způsobené nesprávným zacházením, při soustavném přetěžování stroje, nebo byl-li na výrobku proveden zásah neoprávněnou osobou nebo organizací.

Záruka zaniká při neoprávněném měnění údajů v záručním listě.

Reklamaci uplatňujte pouze u prodejní organizace.

Záruční doba se prodlužuje o dobu, po kterou byl výrobek v opravě.

### **9.2 Obchodní služby**

Záruční a pozáruční servis provádí výrobce ve svém výrobním závodě.

Případné objednávky na náhradní díly zasílejte na adresu výrobce. Náhradní dílce lze objednat též telefonicky.

## **10 Záruční list**

<b>Typ výrobku :</b>	<b>HD230</b>
<b>Výrobní číslo :</b>	.....
<b>Datum prodeje :</b>	Faktura
<b>Doba trvání záruky :</b>	2 roky od data prodeje
<b>Podpis :</b>	.....
<b>Razítko :</b>	

# minimax t 124

woodturning lathe

joinery machines

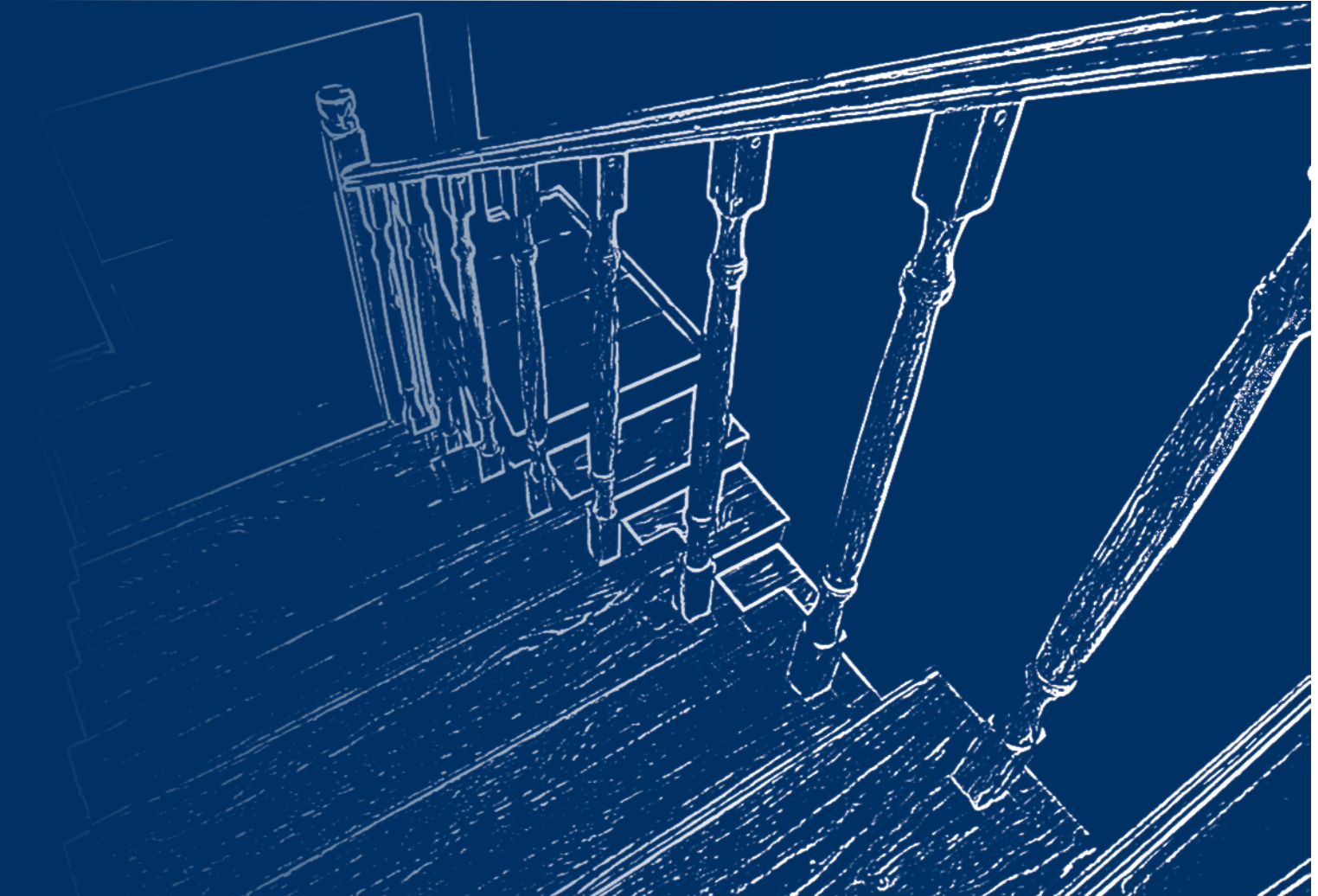

REV. N. 00 - 02.2020 - MFG STUDIO



SCM GROUP SPA  
via Casale 450 - 47826 Villa Verucchio, Rimini - Italy  
tel. +39 0541 674111 - fax +39 0541 674274  
scm@scmgroup.com  
www.scmwood.com



# All “Made in SCM Italy”

*From casting iron to finished product.*

Come see our production plants and touch the quality of SCM machines; you will be our guest.



**minimax**  
the passion that deserves professional products.

minimax is the line of professional machines for hobbyists and woodworkers, a point of reference for over 40 years worldwide.  
SCM's objective is to guarantee customers high quality technologies which meet their requirements in such a way as to make SCM the partner for any needs.

## minimax t 124

Total safety machining.

Woodturning lathe, for demanding DIY woodworkers and craftsmen, fast, cost-effective, easy-to-use, reliable.

# woodturning lathe t 124



		t 124
Distance between centers	mm	1150
Centers height	mm	200
4 spindle speeds (at 50 Hz)	rpm	570 / 1000 / 1850 / 2500
Three-phase motor	kW/Hz	1,5 (1,8) / 50 (60)

Find the complete technical specification at page 7



**Structure**  
precision and safety

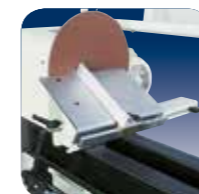

**Optional Devices**  
versatile and complete



Woodturning lathe, for demanding DIY woodworkers and craftsmen, fast, cost-effective, easy-to-use, reliable.

# t 124 operating groups and optional devices

versatile and complete

### Optional Devices.

Full range of devices to realize your  
creativity.

precision and safety

### Structure.

Maximum reliability and top precision, with its  
strong base, and total safety for the operator,  
thanks to the transparent guard.



### Copier.

Enables copying work at  
diameters greater or smaller  
than the template or pattern,  
feed by hand-wheel.

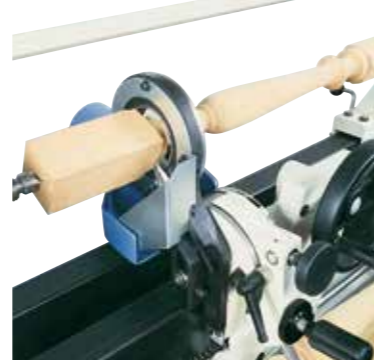

**Mobile Steady Rest,** with  
pre-cutting tool to guarantee  
perfect finishing.



**Fixed Steady Rest,** Reduces  
vibrations when turning  
long, thin components.  
The 'C' shape enables  
turning with hand tools.

# t 124 dimensions and technical data

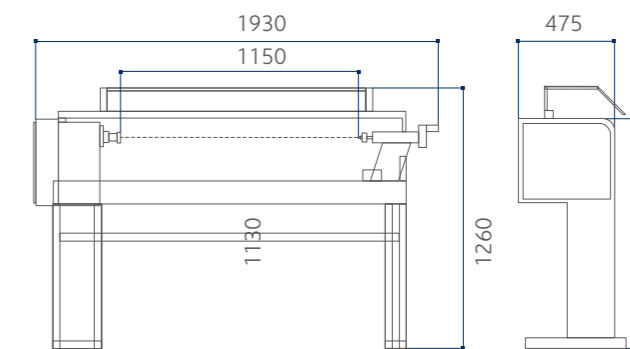

S Standard  
O Option



**Face Plate** 300 mm diameter,  
ideal for large bowls.



**Cup or Screw Type Drive Benders:** 40 mm diameter cup  
centre and 70 mm screw centre made from a single-piece of  
stainless steel. Necessary for turning small cups and bowls.



**A) Sanding Unit,**  
complete with  
adjustable angle  
work surface, guide  
and sanding disc.

**B) Four-jaw Chuck**  
125 mm diameter, for  
the rapid clamping of  
squared or circular  
components.



		t 124
Distance between centres	mm	1150
Centres height	mm	200
4 chuck speed (at 50 Hz)	rpm	570 / 1000 / 1850 / 2500
Tape drive with morse taper	n.	2
Ball bearing centre with morse taper	n.	2
Face plate diameter	mm	130
Machine equipped with copying device (optional)...		
Max. working length	mm	1120
Max. diameter	mm	200
...and equipped with mobile rest (option):		
Max. working length	mm	1070
Max. diameter	mm	80
Three-phase motor 1,5kW (2hp) 50 Hz - 1,8 kW (2,5 hp) 60 Hz		S
Single-phase motor 1,5kW (2hp) 50 Hz		O

# PROMPT AND EXPERT TECHNICAL SUPPORT THROUGH A NETWORK OF 1000 TECHNICIANS AND AN INVENTORY OF 36,000 SPARE PARTS.

HIGHLY SPECIALISED TECHNICIANS, EFFICIENT MANAGEMENT AND 6 SPARE PARTS BRANCHES AROUND THE WORLD GUARANTEE A CLOSE, SAFE AND EFFECTIVE TECHNICAL SUPPORT.

## SERVICE

SCM provides a service that goes beyond the purchase, to guarantee the long term performance of your technological production system and peace of mind for your business.

### A COMPLETE RANGE OF AFTER-SALES SERVICES

- installation and start-up of machines, cells, lines and systems
- tailored training programs
- telephone support to reduce times and costs when machines are not working
- preventive maintenance programs to guarantee long term performance
- complete renovation of machines and plants to renew the added value of the investments
- custom upgrading to update machines and plants and meet new production requirements



## SPARE PARTS

SCM Group can count on 140 spare parts professionals worldwide to meet any request with real time shipments.



### 36,000 SPARE PARTS

Our spare parts inventory, with a value of 12 million euros, covers every single machine



### SPARE PARTS GUARANTEED

We guarantee also hard to find parts, with 3,5 million euros invested in "critical" spare parts.



### IMMEDIATE AVAILABILITY

Over 90% of orders received are carried out the same day thanks to the huge inventory available.



### 6 BRANCHES AROUND THE WORLD

The spare parts service can count on worldwide support (Rimini, Singapore, Shenzhen, Moscow, Atlanta, São Bento do Sul)



### 500 SHIPMENTS A DAY



# THE STRONGEST WOOD TECHNOLOGIES ARE IN OUR DNA

## SCM. A HERITAGE OF SKILLS IN A UNIQUE BRAND

Over 65 years of success gives SCM the centre stage in woodworking technology. This heritage results from bringing together the best know-how in machining and systems for wood-based manufacturing. SCM is present all over the world, brought to you by the widest distribution network in the industry.

65 years history

3 main production sites in Italy

300.000 square metres of production space

20.000 machines manufactured per year

90% export

20 foreign branches

400 agents and dealers

500 support technicians

500 registered patents

In SCM's DNA also strength and solidity of a great Group. The SCM Group is a world leader, manufacturing industrial equipment and components for machining the widest range of materials.

## SCM GROUP, A HIGHLY SKILLED TEAM EXPERT IN INDUSTRIAL MACHINES AND COMPONENTS

### INDUSTRIAL MACHINERY

Stand-alone machines, integrated systems and services dedicated to processing a wide range of materials.



WOODWORKING TECHNOLOGIES



TECHNOLOGIES FOR PROCESSING COMPOSITE MATERIALS, ALUMINIUM, PLASTIC, GLASS, STONE, METAL

### INDUSTRIAL COMPONENTS

Technological components for the Group's machines and systems, for those of third-parties and the machinery industry.



SPINDLES AND TECHNOLOGICAL COMPONENTS



ELECTRIC PANELS



METALWORK



CAST IRON





Company of the Scm Group  
registered office:  
via Emilia, 77  
47921 Rimini, Italia  
T. +39 0541 700111  
F. +39 0541 700232  
sales office:  
via Casale, 450  
47826 Villa Verucchio, Rimini, Italia  
T. +39 0541 674111  
F. +39 0541 674274  
scm@scmgroup.com  
www.scmwood.com

Scm Industria Spa  
Professional Workshop Machinery  
via Valdicella, 7  
47892 Gualdicciolo,  
Repubblica di San Marino  
scm@scmgroup.com  
sales dept. Italy:  
T. +378 0549 876911  
F. +378 0549 999604  
foreign sales dept.:  
T. +39 0541 674111  
F. +39 0541 674274  
www.scmwood.com

The motors powers in this catalogue are expressed in S6,  
except where otherwise specified. In this catalogue, machines  
are shown in CE configuration and with options. We reserve  
the right to modify technical specifications without prior  
notice, provided that such modifications do not affect  
safety as per CE norms.

rev.00  
02/2020

Mic Studio

