



PURCHASE CONTRACT

This purchase contract ("**Contract**") was concluded pursuant to Sec. 2079 *et seq.* of the Act No. 89/2012 Coll., Civil Code ("**Civil Code**"), on the day, month and year stated below by and between:

- (1) **Fyzikální ústav AV ČR, v.v.i.**
(Institute of Physics of the Czech Academy of Sciences, public research institution)
with its registered office at: Na Slovance 2, Praha 8, ZIP 182 21
registration No.: 68378271
enrolled in the Register of public research institutions kept by MEYS
represented by: RNDr. Michael Prouza, PhD. – director

("**Client**"); and
- (2) **STREICHER, spol. s r.o. Plzeň**
with its registered office at: Plzeňská 565, 332 09 Štěnovice
registration No.: 14706768
enrolled in the commercial register kept by District court of Plzeň, item C 301
represented by: Dr. Jiří Lopata, statutory representative, CEO

("**Supplier**").

(The Client and the Supplier are hereinafter jointly referred to as "**Parties**" and individually as "**Party**".)

WHEREAS

- (A) The Client is a public contracting authority and the beneficiary of grants of the Ministry of Education, Youth and Sports of the Czech Republic for different projects aimed on building and further development of the international research laser facility ELI Beamlines ("**Projects**"), within the Operational Programme Research, Development and Education (hereinafter the "**Operational Program**").
- (B) For the successful realization of the Projects, it is necessary to purchase the Object of Purchase (as defined below) in accordance with the Act No. 134/2016 Coll., on public procurement, as amended, and with binding rules of the Operational Program.
- (C) The Supplier's bid for the public contract titled "*L2 Laser Beam Distribution Vacuum Infrastructure [TP22_011]*," whose purpose was to procure the Object of Purchase (hereinafter the "**Bid**" and the "**Public Contract**"), was selected by the Client as the most suitable. Relevant parts of the Bid describing the Object of Purchase (as defined below) and some other related aspects of performing this Contract form Annex 4 (*Supplier's Bid*) to this Contract.



IT WAS AGREED AS FOLLOWS:

1. BASIC PROVISIONS

1.1 Under this Contract, the Supplier shall detail design, manufacture, test and deliver to the place of delivery major components of vacuum infrastructure of the L2 laser beam distribution (vacuum chambers, support frames of the chambers and tubing segments)

(the components to be delivered are hereinafter also referred to as the “**Object of Purchase**” and each separate vacuum chamber, support frame or tubing segment individually as “**System Component**”),

as specified in this Contract, mainly in Annex 1 (Summary of Deliverables, Time Schedule and Payments), Annex 2 (Detailed Technical Specifications of the Object of Purchase), Annex 3 (Verification Control Document) and Annex 4 (Supplier’s Bid) to this Contract and shall transfer to the Client ownership right to the Object of Purchase,

and the Client shall take over the Object of Purchase and shall pay the Supplier the Purchase Price (as defined below),

all under the terms and conditions stipulated herein.

1.2 If, for the fulfilment of the requirements of the Client under this Contract or for the proper operation of the Object of Purchase, other deliveries and activities, not expressly mentioned in this Contract, are necessary, the Supplier shall procure such deliveries or shall carry out such activities at its own expense without any effect on the Purchase Price.

1.3 During performance of this Contract, the Client is entitled to further specify or clarify the requirements stipulated in Annex 2 (Detailed Technical Specification of the Object of Purchase). Such further requirements can be requested by the Client no later than one month before the scheduled completion of the D2 Deliverable. These further requirements shall be binding for the Supplier. Under this provision, the Client is not entitled to substantially change the existing requirements stipulated in Annex 2 (Detailed Technical Specifications of the Object of Purchase). Should any request for change result in an increase of the Purchase Price, such request is binding for the Supplier only if the Purchase Price modification is agreed between the Parties and such modification complies with Act No. 134/2016 Coll., on public procurement, and with binding rules of the Operational Program.

1.4 The Object of Purchase and its components and parts shall be new (i.e. not remanufactured).

1.5 The following activities:

- final cleaning of all vacuum components;
- integration of the vacuum chambers with hinged doors;
- testing of vacuum performance and of vacuum cleanliness of the chambers and of the tubing segments in ISO 7 (or better cleanroom space);

must not be performed by a subcontractor.



- 1.6 The Supplier shall perform this Contract in Deliverables defined in Annex 1 (*Summary of Deliverables, Time Schedule and Payments*).

2. SUPPLIER'S DUTIES

- 2.1 The Object of Purchase shall comply with all technical specifications and performance requirements stipulated in Annex 2 (*Detailed Technical Specifications of the Object of Purchase*). The Object of Purchase and/or its subsystems shall meet valid binding safety, technical and quality Czech and EU standards.
- 2.2 During the performance of this Contract, the Supplier proceeds independently, unless hereunder stated otherwise. If the Supplier receives instructions from the Client, the Supplier shall follow such instructions unless those contradict to the applicable law or this Contract. Should the Supplier find out or should it have found out by exercising professional care that the instructions are inappropriate or contradicting valid law, Czech or EU standards or contradict to this Contract, the Supplier must notify the Client.
- 2.3 Where this Contract makes anything subject to approval by the Client, the Client must not refuse provision of such approval without materially substantiated grounds.

3. CLIENT'S CONFIDENTIAL INFORMATION

- 3.1 For the purposes of the detailed design and manufacture of the Object of Purchase, the Client may provide to the Supplier conceptual drawings, 3D models, schemes and other materials related to the Object of Purchase, which are of confidential nature and which will be labelled as "Confidential and Proprietary" ("**Client's Confidential Information**"). The Supplier acknowledges that the Client's Confidential Information is of proprietary and confidential nature and that such information might be protected under laws that cover industrial or other intellectual property or trade secrets and that disclosure of such information may cause damage or other harm to the Client and/or other third persons. The Supplier may use the Client's Confidential Information solely for the purposes of the fulfilment of this Contract, i.e. for the manufacture and delivery of the Object of Purchase.
- 3.2 The Supplier shall ensure that Client's Confidential Information is accessed only by persons (e.g. employees and/or subcontractors) that need such access for the fulfilment of this Contract. The Supplier shall take all reasonable steps to ensure that the Client's Confidential Information is not accessed by any unauthorized person and/or a third party.
- 3.3 Should the Supplier breach any of his duties stipulated in this Article 3, the Client is entitled to charge him with contractual penalty in the amount of 4 000 EUR for each case of such breach.

4. DESIGN AND MANUFACTURE OF THE OBJECT OF PURCHASE

- 4.1 The detailed 3D model and detailed engineering drawings developed by the Supplier in the Deliverable D2 must comply with the requirements of this Contract and shall be approved by the Client prior to proceeding to elaboration of the production



(manufacture) drawings. If the Client suggests modifications to this 3D model and/or to these drawings, the Supplier shall incorporate such modifications or shall explain in writing the reason for refusing to incorporate them.

5. LICENCE OF THE SUPPLIER

- 5.1 If any part of the Object of Purchase forms an object protected by intellectual property rights laws and/or forms related know-how, the Supplier grants to the Client a right to use such part of the Object of Purchase, including related documentation ("**Supplier's Proprietary Information**") in the original or modified version ("**Licence**") for the purposes listed in Art. 5.3.
- 5.2 The License is granted:
- a) royalty free worldwide;
 - b) for the period of validity of the rights to each of the licensed intellectual property object, which applies adequately to the related know-how.
- 5.3 The Licence comprises the right to use the Object of Purchase for research and development activities within operation of the International Laser Research Facility ELI Beamlines, including necessary modifications to the Object of Purchase including software (if applicable) and limited handover of necessary documentation upon signature of a non-disclosure agreement to third parties for the purposes of operation, servicing and further development of the Object of Purchase.
- 5.4 This granted License also includes the Supplier's permission to the Client to modify and/or alter and/or otherwise change any part of the Supplier's Proprietary Information; either by itself or with assistance of any third party. This permission shall apply *mutatis mutandis* to the Client's entitlement to combine and/or merge any part of the Supplier's Proprietary Information with any other work; either by itself or with assistance of any third party.
- 5.5 The Client is entitled to transfer/ assign the License on any third party if the ownership or operation of the International Laser Research Facility ELI Beamlines passes on such third party. In such case, the Client shall inform the Supplier within undue delay thereabout. The Client is entitled to grant wholly or partially the License to any third party (sublicense) if the right to use the Object of Purchase is granted to such third party.
- 5.6 The Client is not required to use the Licence, unless the maintaining of the right depends on the exercise thereof.
- 5.7 The Supplier hereby represents and warrants to the Client that:
- a) It is entitled to use and enforce all intellectual property rights to the Supplier's Proprietary Information, in order to be ensured that the Client may use the Supplier's Proprietary Information properly and without any interference; and
 - b) It is entitled to grant the License to the Client in the extent specified in this Contract.



5.8 If the Licence is endangered or infringed, the Client shall inform the Supplier accordingly without undue delay after ascertaining this fact. The Supplier shall provide the Client with cooperation to ensure the legal protection of the Licence. The Supplier shall give the Client consent to enforce the industrial property rights and/or related know-how rights covered by the License.

6. MONITORING AND IMPLEMENTATION OF THE INSPECTION PLAN

6.1 The Supplier undertakes to enable the Client exercising inspections of the performance of this Contract. For this purpose, the Supplier shall provide the Client with all information regarding the status of the design and manufacture of the Object of Purchase at the request of the Client, anytime during performance of this Contract.

6.2 The Supplier shall provide the Client with all cooperation, assistance and information that the Client needs for the purposes of full evaluation of the status of the design or manufacture of the Object of Purchase.

6.3 If the Client, especially during an inspection, ascertains any breach of the Supplier's duties under this Contract, the Client shall notify in written the Supplier of such breaches. The Supplier has to respond to such notification and suggest, in an appropriate detail, remedying the deficiencies, within fourteen (14) calendar days, unless the Parties agree otherwise.

6.4 Each Party shall invite the other Party to attend a meeting in writing at least 14 calendar days in advance. The Parties may replace, upon mutual agreement, meetings in person by other forms of communication, as long as they agree on such in advance. Each Party shall bear its expenditures related to their participation in meetings at the other Party's facility; however, costs which would arise due to an error, faulty performance or a breach of contractual provisions of the Parties shall be borne by that Party which caused it.

6.5 The Supplier shall follow the Quality and Verification Plan addressing all requirement items stated in Annex 3 (*Verification Control Document*) and shall invite the Client at least 14 calendar days in advance to participate in all relevant activities of this Plan.

6.6 In fulfilment of Deliverables D1 and D2, where early agreement on specific design features as described in Annex II (*Detailed Technical Specifications of the Object of Purchase*), and/or where guidance by the Client may be needed for proper execution of the works, the Supplier will contact the Client with a written technical query, which the Client shall respond in 14 calendar days. If the Client does not respond within 14 calendar days, the Supplier is entitled to choose the technical solution he considers most appropriate.

6.7 If the Client does not participate in an inspection and/or verification activity according to Annex 3 (*Verification Control Document*) at the date communicated in accordance with Art. 6.5, the Supplier is not entitled to carry out respective activities in absence of the Client. However, in such a case the Supplier is not in delay with completion of the corresponding Deliverable and subsequent Deliverables with proven dependency on the



corresponding Deliverable and delivery periods of such Deliverables shall extend by the time of the Client's delay, unless the Parties agree otherwise.

7. THE PLACE AND TIME OF DELIVERY

- 7.1 The place of delivery shall be the International Research Laser Facility ELI-Beamlines located at Průmyslová 836, Dolní Břežany (district Prague-West), ZIP 252 41, Czech Republic (hereinafter also "ELI Beamlines" or "ELI Beamlines site").
- 7.2 The Supplier shall perform individual Deliverables in terms stipulated in Annex 1 (*Summary of Deliverables, Time Schedule and Payments*).
- 7.3 The Supplier shall carry out performance and verification tests of all System Components of the Object of Purchase at his premises (factory acceptance tests), in relation with Deliverables D3 and D4, prior shipment of the respective System Components, on the dates agreed with the Client in accordance with Art. 6.5, according to Annex 3 (*Verification Control Document*).
- 7.4 For the purpose of determination of individual deadlines stipulated hereby the **Commencement Day** shall be the seventh calendar day after the Contract is concluded (i.e. signed by the second of the Parties).

8. PRICE AND PAYMENT TERMS

- 8.1 The total purchase price for the Object of Purchase is **10 220 000,-** Czech Crowns (CZK) without value added tax ("VAT") ("**Purchase Price**"). The Purchase Price represents the Supplier's binding maximum price.

The Purchase Price shall be invoiced and paid upon acceptance of any Deliverable in instalments (hereinafter also "**Payments**") stated in Annex 1 (*Summary of Deliverables, Time Schedule and Payments*).

The VAT shall be imposed on top of all payments made hereunder according to valid legislation.

- 8.2 The Purchase Price cannot be exceeded.
- 8.3 The Purchase Price includes all costs and expenses of the Supplier related to the performance of this Contract. The Purchase Price include especially all expenses related to the design, manufacture, assembly, factory testing, cleaning, performance verification and delivery to ELI-Beamlines of the Object of Purchase or its parts, costs of the Licence, insurance, warranty service, development of prices of materials (unless expressly stated otherwise in this Contract), development of foreign currency exchange rates, customs (if applicable) and any other costs and expenses related to the performance of this Contract.
- 8.4 The Purchase Price may be changed only in accordance with the Act No. 134/2016 Coll., on public procurement, as amended.
- 8.5 If the Supplier performs the subject-matter hereof duly in line herewith without substantial breaches of the Contract and if there are no obvious reasons for doubts on



continuing of the due performance hereof by the Supplier, by taking into account the overall approach of the Supplier to the Contract performance (presented particularly by due preparation for performance of follow-up activities), and if it might ease further performance hereof by the Supplier, the Client reserves the right fully on its discretion to provide the Supplier with the Payments or any parts of them sooner than scheduled hereunder or in higher amount than stipulated by Annex No 1 hereto, Summary of Deliverables, Time Schedule and Payments (i.e. any Payments might be increased with proportional decreasing of subsequent Payments). If the conditions stipulated above are met, the Client is entitled to modify the payment schedule included in the Annex No 1 hereto anyhow in favour of the Supplier and to provide it with any prepayment.

- 8.6 The Purchase Price instalments shall be paid based on tax documents – invoices, to the account of the Supplier designated in the invoice. The Purchase Price shall be paid following the payment schedule set out in Annex 1 (Summary of Deliverables, Time Schedule and Payments). The Supplier is entitled to issue any invoice no sooner than on the moment a Deliverable is duly completed and accepted by the Client in accordance with this Contract.
- 8.7 The Client shall execute payments on the basis of duly issued invoices within 30 days from their receipt. If the Supplier stipulates any shorter due period in an invoice such different due period shall not be deemed relevant and the due period stipulated herein prevails. Any invoice shall be considered to be paid for on the day when the invoiced amount is deducted from the Client's account on behalf of the Supplier's account.

The invoices shall be sent to the Client solely in the electronic form to the address efaktury@fzu.cz

- 8.8 Any invoice issued by the Supplier as a tax document must contain all information required by the applicable laws of the Czech Republic. The Client shall advise the Supplier on the proper contents of invoices if requested prior to invoicing.

Furthermore, invoices shall include:

- a) registration number of this Contract, which the Client shall communicate to the Supplier based on Supplier's request before the issuance of the invoice,
- b) registration number and a title of a grant Project in accordance with information provided by the Client,

and must comply with the double tax avoidance agreements, if applicable.

- 8.9 In case that the invoice does not contain the above mentioned information, the Client is entitled to return it to the Supplier during its maturity period and this shall not be considered as a default. The new maturity period shall begin from the receipt of the supplemented or corrected invoice to the Client.

Material costs development



- 8.10 Should the actual price of the categories of the raw material (stainless steel) identified in the Bid of the Supplier at the moment of purchase increase or decrease by more than 10 % with respect to their price considered in the Bid, the Supplier and the Client shall proceed in compliance with the below-stated rules.

The Supplier shall make all reasonable efforts to secure as low as possible price made possible by the overall behavior of the market for designated raw material.

Regarding the categories of stainless steel as specified in the Bid, the Supplier shall inform the Client, without undue delay, on selection of the suppliers (sub-contractors) for each purchase, with justification of the selection. The justification shall be based on a competitive tender (documented especially by relevant price enquiries sent to more suppliers), and shall use the criterion of the most economically advantageous tender to select the supplier (sub-contractor).

Price increase

Should the actual unit price of the identified categories of raw materials, as mentioned above, and for the maximum total extent specified in the Supplier's Bid, at the moment of purchase for fulfilment of this Purchase Contract increase by more than 10 % with respect to their price considered in the Bid, the Supplier is entitled to ask the Client for compensation of the extra costs incurred, in the amount above the price level considered in the bid.

Should the following conditions:

- a) the increased price is documented by the outputs of the competitive tender;
and
- b) the difference between the unit price in the bid and the actual purchase price is consistent with the overall behavior of the market for the respective material in the relevant timeframe (using the indexes published by the London Metal Exchange (<https://www.lme.com/>);

be met, the Client shall agree with the Supplier on corresponding increase of the prices of the raw material in the Purchase Contract.

Due to the budgetary limitations of the Client, the total permitted price increase of the raw materials under this clause is limited to 1 000 000 CZK (or to an equivalent of this amount in the currency of the actual purchase).

Should the Client have doubts regarding the cost figures of the raw materials presented by the Supplier, it is entitled to refuse any such price increase.

Price decrease

Should, based on the competitive tender, the actual unit price of the identified categories of raw materials, as mentioned above, and for the total expected extent specified in the Supplier's Bid, decrease by more than 10 % with respect to their price considered in the Bid, the Purchase Price shall be decreased by the corresponding amount (in the amount with respect to the price level considered in the Bid).



The Purchase Price invoiced by the Supplier shall in such case be decreased by the financial amount saved (by decreasing invoiced Payments for the corresponding Deliverables).

Joint provision

Agreements or understandings between the Parties needed to implement the reserved changes in obligations above shall be made in written, however, they do not need to take the form of an amendment to this Contract.

9. **ACCEPTANCE OF DELIVERABLES, HANDOVER OF INDIVIDUAL PARTS OF OBJECT OF PURCHASE**

9.1 Upon receiving any documents, reports or designs necessary for completion of Deliverables D1 and D2, the Client shall provide the Supplier within 10 working days with his comments to the submitted documents. The Supplier shall be obliged to take the Client's comments into account, i.e. the Supplier shall accept all justified and materially correct comments and requirements for changes made by the Client. Should the Supplier consider any of the comments or requirements made by the Client as materially incorrect or unacceptable, the Supplier shall specify in writing his reasons for refusing to accept them. The Supplier will produce final documents containing all justified and materially correct comments and requirements for changes raised by the Client.

9.2 Upon due completion of any Deliverable and upon fulfilling the requirements of the Client as set forth herein and in Annex 1 (*Summary of Deliverables, Time Schedule and Payments*), the Client shall issue to the Supplier, without undue delay, a confirmation on the due execution of the Deliverable (the "**Deliverable Acceptance Protocol**").

9.3 On-site acceptance, and handover and takeover of individual parts of the Object of Purchase (System Components), upon fulfilling the requirements of the Client as set forth in Annex 1 (*Summary of Deliverables, Time Schedule and Payments*), related to Deliverables D3 and D4 shall be realized on the basis of a Deliverable Acceptance Protocol, which shall contain at least the following information:

- a) identification of the Supplier, Client and subcontractors, if there are any;
- b) identification of the Deliverable;
- c) declaration of the Client that he received from the Supplier all technical information and documentation related to the Deliverable;
- d) statement of the Client on acceptance of the Deliverable;
- e) list of defects, and/or backlogs or performance deficiencies, if any;
- f) date of the signature.

9.4 The Deliverable Acceptance Protocol for D3 and D4 must contain the following annexes, which shall be provided by the Supplier:

- a) list of items (accessories) handed over within the corresponding Deliverable;



- b) protocols with full results of all design and/or manufacturing inspections and of performance verification testing, carried out according to Annex 3 (Verification Control Document);
 - c) drawings, 3D models, and other contractually required information and documentation corresponding to the Deliverable.
- 9.5 In case of deficiencies (i.e. defects and/or backlogs) of the delivered subsystems related to Deliverables D3 and D4, mainly if the Supplier does not hand over to the Client all required documentation, or if a Deliverable does not comply with this Contract, the Client is entitled to refuse the takeover and acceptance of that Deliverable. Whenever technically possible the Supplier shall remedy the deficiencies within ten (10) working days, unless Parties agree otherwise (particularly due to the fact that period of 10 working days is technically impossible). However, these periods do not imply that the Supplier is not in delay with the delivery of the respective Deliverable.
- 9.6 The Client is entitled at his discretion (but not obliged) to take over and accept the respective Deliverable despite the above mentioned deficiencies, in particular if such deficiencies do not prevent the Client from the intended use of the respective part of the Object of Purchase (System Component). In such case the Parties shall list the deficiencies in the respective Deliverable Acceptance Protocol(s), including the manner and the date of their removal (remedy). If the Parties do not reach agreement regarding the date of the removal, the Supplier shall remove the deficiencies within ten (10) working days. Should the deadline of ten (10) working days be technically impossible and should the Supplier document an actually needed longer term, the Client shall agree on the documented longer term. Until the remedy of the deficiencies, the Client shall be entitled to postpone the corresponding payment up to the amount corresponding to the significance of the deficiency.
- 9.7 The Client shall not be obliged to verify the correctness of all calculations and/or technical solution details during the course of the acceptance of the Deliverables relating to the detailed design, fabrication process, and on-shop testing. Acceptance of individual Deliverables does not release the Supplier from his liability for the technical compliance and completeness of the Object of Purchase.
- 9.8 Should it be necessary to modify any part of the already accepted Deliverable in order to meet any requirement stipulated herein, the Supplier undertakes to perform such modifications and accepts that the costs related thereto are included in the Purchase Price.
10. **THE OWNERSHIP RIGHT**
- The ownership right to the subsystems of the Object of Purchase (individual System Components) corresponding to the Deliverables D3 and D4, shall pass to the Client upon their handover and acceptance confirmed by the signature of the respective Deliverable Acceptance Protocol by both Parties.



11. WARRANTY

- 11.1 The Supplier provides a warranty of quality related to any already accepted and handed over part of the Object of Purchase (System Component) for the period of 24 months from execution of the Deliverable Acceptance Protocol for the respective System Component, unless a longer warranty length is specified in *Annex 4 (Supplier's Bid)*. If on a warranty list or other document submitted by the Supplier the warranty period is of longer duration than stipulated by this Contract, then this longer warranty period shall have priority over the period stated in this Contract.
- 11.2 If any Deliverable Acceptance Protocol for D3 or D4 lists any deficiencies, the warranty period for the respective System Component shall begin on the day on which the last deficiency was removed.
- 11.3 The Supplier shall remove defects for which he is responsible according hereto that occur during the warranty period free of charge and in the terms stipulated in this Contract. The Supplier shall bear all the expenses (e.g. shipments, travelling, accommodation expenses and price of equipment rental or purchase) related to removal of the defects.
- 11.4 If the Client ascertains a defect of the Object of Purchase during the warranty period, the Client shall notify such defect without undue delay to the Supplier. Defects may be notified on the last day of warranty period, at the latest.
- 11.5 The Client notifies defects in writing via e-mail. The Supplier shall accept notifications of defects on the following e-mail address: benda@streicher-machinery.cz. The Supplier shall confirm receipt of the notification within two working days.
- 11.6 In the notification, the Client shall describe the defect and the manner of removal of the defect. The Client has the right to ask for:
- a) the removal of the defect by the delivery of a replacement individual part of the Object of Purchase,
 - b) the removal of the defect by repair, or
 - c) the adequate reduction of the Purchase Price, particularly in case of irremovable defects.

The choice among the above mentioned rights belongs to the Client. However, the Client is not entitled to request the delivery of a new Object of Purchase or its part(s) in case of removable defects unless the same defect occurs repeatedly. The Client is also entitled to withdraw from this Contract, if by delivering the Object of Purchase with defects this Contract is substantially breached.

- 11.7 The Supplier shall remove the defect within 21 calendar days from its notification, unless Parties agree otherwise. The Client shall agree an extended deadline for the defect removal with the Supplier if the Supplier submits evidence (e.g. subcontractors bid etc.) that the removal of the defect within 21 calendar days is impossible for objective reasons (i.e. independent of the will of the Supplier), or if technical nature of the defect makes not possible its removal within 21 calendar days.



- 11.8 The Supplier shall remove the defect within terms stipulated in this Contract even if the notification of the defect is in his opinion unjustified. In such a case, the Supplier is entitled to ask for reimbursement of the costs of the removal of the defect. If Parties disagree on whether the notification of the defect is justified or not, the Client shall secure an expert opinion (by an expert also agreed by the Supplier). If the expert considers the notification to be justified, then the Supplier shall return the reimbursement amount paid to him in accordance with the second sentence of this paragraph.
- 11.9 Parties shall sign a protocol on the removal of a defect, which shall contain the description of the defect and the confirmation that the defect was removed. The warranty period of the relevant defective System Component shall be extended in case of defects preventing the Client from use of the System Component for intended use by the period of time that elapses between the notification of the defect and its removal.
- 11.10 Should the Supplier not remove the defect within the stipulated or mutually agreed term or should the Supplier refuse to remove the defect, the Client is entitled to remove the defect at his own costs and the Supplier shall reimburse these costs within 30 days after the Client's request to do so. In such a case, the existing warranty remains intact.

12. REPRESENTATIONS AND WARRANTIES OF THE SUPPLIER

- 12.1 The Supplier represents and warrants to the Client that
- a) he possesses all professional qualifications to supply the Object of Purchase, has all the professional prerequisites necessary for the proper fulfilment of this Contract and is able to carry out activities foreseen hereunder with the due care, skill and knowledge of well-experienced experts in his particular professional field,
 - b) is fully authorized to perform this Contract, and
 - c) there are no obstacles on his side that would preclude him from the due performance of this Contract.
- 12.2 The Supplier is aware of the importance to the Client of the fulfilment of this Contract in terms of quality, performance and schedule. In the event of a failure by the Supplier to meet them (e.g. in case of delay with delivery of Deliverables and/or in the case if the Object of Purchase does not meet the performance requirements), substantial damage may arise to the Client.
- ## 13. PENALTIES
- 13.1 If the Supplier is in delay with the Deliverables D1 or D2 for more than one month, the Supplier shall pay starting with the first day of the second month of the delay to the Client a contractual penalty in the amount of 0.05% of the price of the respective Deliverable (excl. VAT) for every even incomplete day of delay. The Payment for any Deliverable as



stated in Annex 1 is considered to be the price of the Deliverable for the purposes of this Art. 13.1.

- 13.2 If the Supplier is in delay with the Deliverables D3 or D4 the Supplier shall pay to the Client a contractual penalty in the amount of 0.05% of the Purchase Price (excl. VAT) for every even incomplete day of delay.
- 13.3 If the Supplier is in delay with the removal of a defect of the Object of Purchase preventing the Client from proper operation of the Object of Purchase, the Supplier shall pay to the Client a contractual penalty in the amount of 0.05% of the Purchase Price (excl. VAT) for every even incomplete day of delay. In case of defects that do not prevent the Client from proper operation of the Object of Purchase the contractual penalty shall amount to 0.02% of the Purchase Price (excl. VAT) for every even incomplete day of delay.
- 13.4 The Supplier shall pay any of the contractual penalties charged under this Contract within thirty (30) days from the day, on which the Client enumerated its claim for the contractual penalty. The payment of contractual penalties shall not affect the right of the Client to damages in the extent in which such damages exceed the contractual penalty.
- 13.5 The amount of the contractual penalty for delay with completion of any of the Deliverables D1 or D2 shall not exceed 5% of the price of each respective Deliverable.
- The total amount of contractual penalties for delay with completion of Deliverables D3 and D4 (i.e. the summed up amount of all penalties for delays with the Deliverables D3 and D4) shall not exceed 5% of the Purchase Price.
- 13.6 Should a delay of the Supplier be caused by a documented impact of the Covid-19 pandemic or of the war in Ukraine on the course of performance of this Contract by the Supplier (e.g. sick workers, sub-supplies delays or failures, etc.), the contractual penalties for delay above do not apply. The Supplier shall in sufficient detail document when an obstacle occurred and how long it lasted. The penalties do not apply also in the case of such obstacle caused by Covid-19 pandemic or by the war in Ukraine, which could have been overcome but only with unreasonable efforts or disproportionate costs.
- 13.7 The Client is entitled to unilaterally set off claims arising from the contractual penalties against even yet undue claim of the Supplier for the payment of the Purchase Price.

14. **RIGHT OF WITHDRAWAL AND VIS MAJOR**

- 14.1 The Client is entitled to withdraw from this Contract without any penalties, if any of the following circumstances occur:
- a) the Supplier breaches this Contract in a substantial manner;
 - b) the Supplier repeatedly fails to follow the mandatory activities listed in the Verification Control Document, stipulated in Annex 3, and/or does not allow the Client to inspect the Supplier's premises for the purposes of ascertaining status of fulfilment of the Contract;



- c) the Supplier is in delay with any contractual Deliverable stipulated in Annex 1 for a period exceeding 3 (three) calendar months, except where the delay has been caused by the Client;
 - d) results of the factory testing, even after third testing attempt, do not meet the requirements stipulated in Annex 2 (*Detailed Technical Specifications of the Object of Purchase*);
 - e) the insolvency proceeding is initiated against the Supplier; or
 - f) the Client ascertains that the Supplier provided in its Bid submitted for the Public Contract information or documents that do not correspond to the reality and that had or could have had impact on the result of the tendering procedure for the Public Contract.
- 14.2 The Supplier is entitled to withdraw from this Contract in the following cases:
- a) the Client breaches this Contract in a substantial manner;
 - b) the Client is in delay with the payment of any Deliverable for a period longer than 3 calendar months; or
 - c) the Client repeatedly refuses his attendance at the respective verification activities specified in the Verification Control Document, stipulated in Annex 3.
- 14.3 The act of withdrawal from the Contract shall become effective on the day of delivery of a written withdrawal notice to the other Party with consequences of the Contract termination effective in the “ex tunc” regime, unless the Parties agree otherwise.
- 14.4 Circumstances precluding liability shall be deemed to have been constituted by such circumstances / obstacles which arose independently of the will of the obliged Party, and which prevent fulfilment of that Party’s obligation, provided that it could not be reasonably expected that the obliged Party could overcome or avert this obstacle or its consequences, and furthermore that such Party could foresee such obstacle when it entered into the respective covenants. Liability cannot be precluded by obstacles that arose only after the obliged Party was in default with fulfilment of its obligations, or which arose in connection with its economic situation. The effects precluding liability shall be limited to the period during which the obstacles causing these effects persist.
- 14.5 Any particular effects or impacts on the Supplier or his performance under this Contract of the Covid-19 pandemic or of the war in Ukraine that meet the conditions set out above in Art. 14.4 (unless differently stated in this Art. 14.5) and that could have been overcome only with unreasonable efforts or disproportionate costs will be considered as vis major cases, despite the fact of the existence of the epidemic outbreak and of the war as of the date of conclusion of this Contract.
- 14.6 Should a situation occur, which a Party could reasonably consider to constitute vis major (force majeure), and which could affect fulfilment of its obligations hereunder, such Party shall immediately notify the other Party and attempt to continue in its performance hereunder in a reasonable degree. Simultaneously, such Party shall inform the other one



of any and all its proposals, including alternative modes of performance, however, without the other Party's consent, the Party shall not proceed to carry out such alternative performance. If a situation constituting vis major occurs, the deadlines imposed hereunder shall be extended by the period of the duration of the said vis major. The Parties may agree on confirmation of the deadlines extension by entering an amendment to this Contract.

15. **CONFIDENTIALITY**

Parties shall not disclose information that shall become available to them in connection with this Contract and its performance and whose disclosure could harm the other Party. Duties of the Client ensuing for the applicable legal regulations remain unaffected.

16. **SOCIAL, ECOLOGICAL AND INNOVATIVE ASPECTS**

The Client aims to conclude contracts with suppliers that take into account and implement the principles of social responsibility, ecological sustainability and innovation. Therefore, the Supplier shall ensure that:

- a) this Contract is fulfilled only by persons that are employed in accordance with the applicable legal regulations (no illegal or child workers);
- b) while performing this Contract, all applicable health and safety regulations and rules at work place are observed;
- c) all persons performing this Contract are employed under fair and non-discriminatory working conditions;
- d) if presented with different manners of fulfilling this Contract, the Supplier shall select the solution/process that is in accordance with the principles governing nature conservation and nature protection, ecological sustainability and ecological waste management; and
- e) if presented with different manners of fulfilling this Contract, the Supplier shall select the solution/process that is the most innovative.

17. **REPRESENTATIVES OF THE PARTIES**

17.1 The Supplier appoints the following representative for the communication with the Client in technical matters:

Name: [REDACTED]
E-mail: [REDACTED]
Tel.: [REDACTED]

17.2 The Client appoints the following representative for the communication with the Supplier in technical matters:

Name: [REDACTED].
E-mail: [REDACTED]
Tel.: [REDACTED]



18. ASSIGNMENT

- 18.1 The Supplier shall not be entitled to assign any rights or obligations arising in connection herewith to a third party.
- 18.2 The Client makes the Supplier aware that the Client is going with anticipated effect as of 1.1.2023 to transfer the ELI Beamlines research facility (now owned and operated by the Client) for construction and operation of which is the supply under this Contract being agreed to to The Extreme Light Infrastructure ERIC (ELI ERIC). The ELI ERIC is a legal person set up under Regulation (EC) No 723/2009 and it is the future long term owner and operator of the ELI Beamlines facility. The Supplier by entering this Contract agrees to the assignment of all rights and obligations from this Contract by the Client to ELI ERIC. The Client shall inform the Supplier on the completed assignment without undue delay and the assignment shall become effective at the moment of its notification to the Supplier. The supply supplied under this Contract will be used exclusively in the ELI Beamlines facility.

19. FINAL PROVISIONS

- 19.1 This Contract is governed by the laws of the Czech Republic, especially by the Civil Code.
- 19.2 All disputes arising out of this Contract or out of legal relations connected with this Contract shall be preferably settled by a mutual negotiation. In case that the dispute is not settled within sixty (60) days, such dispute shall be decided by courts of the Czech Republic in the procedure initiated by one of the Parties.
- 19.3 The Supplier takes into account that the Client is not in relation to this Contract an entrepreneur, nor the subject matter of this Contract is connected with the business activities of the Client.
- 19.4 The Supplier is not entitled to set off any of its claims or his debtor's claims against the Client's claims.
- 19.5 All modifications and supplements of this Contract must be in writing.
- 19.6 If any provision of this Contract is or becomes invalid or ineffective, then such invalidity, ineffectiveness or unenforceability shall not cause the invalidity, ineffectiveness, or unenforceability hereof as a whole and the Parties shall change this Contract in such a way that the invalid or ineffective provision is replaced by a new provision that is valid and effective and to the maximum possible extent correspond to the original invalid or ineffective provision as well as most closely reflects the intentions of the Parties at the time of conclusion hereof, to an extent permitted by the laws and regulations of the Czech Republic.
- 19.7 If any Party breaches any duty under this Contract and knows or should have known about such breach, it shall notify it to the other Party and shall warn such Party of possible consequences of the breach.
- 19.8 Integral parts of this Contract are:



Annex 1 (Summary of Deliverables, Time Schedule and Payments)

Annex 2 (Detailed Technical Specifications of the Object of Purchase)

Annex 3 (Verification Control Document)

Annex 4 (Supplier's Bid)

In case of any discrepancy between any provisions of this Contract and any provisions of its Annexes the provisions of this Contract shall prevail. In case of any discrepancy between any provisions of Annexes hereof the provisions containing conditions and specifications that are more favourable to the Client (i.e. higher technical specification values and/or more technically advanced or demanding solutions etc.) shall prevail.

- 19.9 This Contract shall be valid on the date of the signature of both Parties and effective on the date of its publication in the Register of contracts according to special legal regulation.

IN WITNESS WHEREOF attach Parties their signatures:

Client

Signature: _____

Name: RNDr. Michael Prouza, PhD

Position: Director

Supplier

Signature: _____

Name: Dr. Jiří Lopata

Position: CEO



EUROPEAN UNION
European Structural and Investing Funds
Operational Programme Research,
Development and Education



MINISTRY OF EDUCATION,
YOUTH AND SPORTS

ANNEX 1

SUMMARY OF DELIVERABLES, TIME SCHEDULE AND PAYMENTS

Annex No. 1
Summary of Deliverables,
Time Schedule and Payments

L2 Laser Beam Distribution Vacuum Infrastructure
[TP22-011]

TC ID/Revision: 00332368/A
 Confidentiality: BL - Restricted for internal use
 WBS code: 4.2 - Beam Transport
 PBS code: SE.BDS.BT.L2BT.S1, SE.BDS.BT.L2BT.S5

Deliverable	Description	Completion	Payment
	Commencement day (CD) = Contract signature + 7 calendar days	-	-
D1	Detailed schedule of project activities and all corresponding Quality and Verification Plans, and of work procedures	1 month from CD	10% of total cost
D2	Detailed engineering design of CH1, CH2, CH3, CH4 and CH5, of their support frames, and of the tubing segments	3 months from CD	30% of total cost
D3	Manufacture and factory testing of CH3, CH4 and CH5, of their support frames, and of the tubing segments TS3 and TS4, delivery to ELI-Beamlines	7 months from CD	30% of total cost
D4	Manufacture and factory testing of CH1 and CH2, of their support frames, and of the tubing segment TS1, delivery to ELI-Beamlines	9 months from CD	30% of total cost

I. Contractual Deliverables description

1. Deliverable D1:

Detailed schedule of project activities and all corresponding quality plans and work procedures

The supplier to whom the Public Contract will be awarded (hereinafter the “**Supplier**”) shall provide a detailed schedule of all project activities; by which is meant a schedule that defines all the activities necessary to individually define, produce or procure and deliver every component within the scope of supply. All activities shall be resourced, allocated start / finish times and linked with relevant dependencies. The amount of detail should be sufficient to identify the longest path of activities through the entire program, thus providing confidence in the overall programme for Deliverables. The scheduled activities shall not be restricted to those of the Supplier but shall include all relevant activities of sub-suppliers, the Client or relevant third parties.

Also within the first month following the Commencement Day, the Supplier shall provide a draft set of Quality and Verification Plan and associated Work Procedures detailing all the work activities and processes required for the design, procurement, fabrication, assembly and test of all products to be supplied under the contract. This shall include aspects such as design review, inspection, analysis and test procedures (Verification Plan), and configuration management, material traceability, cleanliness control, welding procedures and qualifications (Quality Plan). The provided draft set of Quality and Verification Plan shall incorporate as a minimum all required activities listed in Annex 3 (*Verification Control Document*).

Completion: 1 month after Commencement Day

2. Deliverable D2:

Detailed engineering design of CH1, CH2, CH3, CH4 and CH5, of their support frames, and of all tubing segments

- a) The Supplier shall develop detailed engineering 3D models of all chambers CH1, CH2, CH3, CH4 and CH5, of their support frames SF1A, SF1B, SF2A, SF2B, SF3A, SF3B, SF4A, SF4B, SF5A, and SF5B, and of the tubing segments TS1, TS3 and TS4, based on the preliminary design drawings and 3D models supplied by the Client. These detailed engineering models produced by the Supplier will be used in the subsequent step (Deliverables D3 and D4) to make production drawings. The purpose of the detailed engineering design is to develop the Client’s preliminary design into a full model including all necessary mechanical details and to optimize the overall design with respect to the technologies, functionality, and fabrication methods that will be employed for manufacturing. The accepted detailed 3D model and the detailed engineering drawings developed in this Deliverable will be binding for the Supplier in the manufacturing phase (Deliverables D3 and D4).
- b) A part of this Deliverable D2 will be elaboration of specific details of the design, such as:
- Lifting mechanism / lifting points (e.g. lifting eyes) for manipulation with the chambers, doors, and tubing segments
 - O-ring arrangement with trapezoidal grooves for the chamber doors
 - Door hinges with double pivot arrangement
 - SF5B chassis (frame) supporting the internal optomechanics of the CH5 chamber to include e.g. detachable profiles, in order to provide temporary access to CH5 underside
 - Paths along the chambers for utilities, primary backing vacuum and electrical cables, followed by design of C-rails and cable trays on the chambers, and by determination of holes in the ribs for utilities
Note: The points of arrival of the primary vacuum and utilities, as well as connection to backbone facility cable tray(s) will be specified by FZU.

- Connection between the chambers and their supporting frames and/or other features required for easy installation of the chamber assembly including the optomechanical supporting frame
 - Determination of materials, arrangement of welds and welding procedures, manufacturing process of implementation of the A Tolerance Grade flanges, surface finishes and other similar matters necessary to optimize for fabrication
- c) The Supplier shall verify the stiffness and stress of the developed detailed design of all chambers and of the tubing segments, by means of FEA (Finite Element Analysis) simulations. The acceptable limit of deformation under atmospheric pressure differential is included in the detailed specification of performance requirements in Annex 2 to this Contract. Analysis of the concept design made by the Client shows that the specified requirements are realistic. Results of the analysis shall be provided by Supplier to Client for review. Status of appropriate requirements to be verified by the analysis shall be tracked by the Verification Control Document (VCD), see Annex No. 3.
- d) A brief technical report shall be provided by the Supplier that lists all the significant changes and enhancements between the Client's concept design and the agreed detail design. For each change there shall be a brief description of the reason for change and justification of the selected solution. This will provide a means of checking that no important features of the concept design have been inadvertently lost or corrupted.
- e) The Supplier shall provide detailed drawings and detailed 3D model of CH1, CH2, CH3, CH4, CH5, SF1A, SF1B, SF2A, SF2B, SF3A, SF3B, SF4A, SF4B, SF5A, SF5B, TS1, TS3, and TS4, including the finally agreed configuration.
- f) The Supplier shall provide final Quality and Verification Plan for all the main components and other documentation, which will be reviewed by the Client.

The provided documentation shall be reviewed by Client by means of Critical Design Review (CDR) process for the part of supply corresponding to D2, and its results will be recorded in a CDR Report. The verification of the Design shall be considered complete when the Client and the Supplier mutually agree that, on the basis of the CDR Report and on the basis of the Verification Control Document (VCD) that all corresponding requirements related to the Design were closed out and that all associated verification objectives were fully achieved. The status of the requirements verified in the Review of Design shall be tracked by the Verification Control Document (VCD), see Annex No. 3, and shall be the basis for acceptance of the Design.

The Supplier shall further submit a timetable of individual major steps in the manufacturing process and factory testing related to D3 and D4. The Client reserves the right to witness verification and testing of the individual components and subsystems at the Supplier's premises at any of the indicated steps in the manufacturing process, and to monitor implementation of the contract.

Completion: 3 months after Commencement Day

3. Deliverable D3:

Manufacture and factory testing of CH3, CH4 and CH5, of their support frames, and of the tubing segments TS3 and TS4, delivery to ELI-Beamlines

The Supplier shall develop a full set of final production drawings of the chambers CH3, CH4 and CH5, of the support frames SF3A, SF3B, SF4A, SF4B, SF5A, and SF5B, and of the tubing segments TS3 and TS4, in line with the documentation produced within the D2 Deliverable.

The Supplier shall manufacture CH3, CH4, CH5, SF3A, SF3B, SF4A, SF4B, SF5A, SF5B, TS3, and TS4, and will perform inspection and testing of vacuum welds according to requirements in Annex 2 (Requirements Specification Document) and Annex 3 (Verification Control Document) of this Contract. The Supplier shall invite the Client for inspecting the testing of vacuum welds.

The chambers CH3, CH4 and CH5, and tubing segments TS3 and TS4 shall be vacuum cleaned according to requirements in Annex 2 to this Contract. The Supplier shall transport the chambers and the tubing segments into a Class 7 or better cleanroom, where all assembly operations, vacuum performance testing, and vacuum cleanliness verification shall be made.

The Supplier shall provide all equipment for the required vacuum performance and cleanliness testing, namely vacuum pumps, vacuum gauges, He leak detector, and RGA mass spectrometer.

The Supplier shall validate the vacuum performance and vacuum cleanliness of the chambers CH3, CH4 and CH5, and of the tubing segments TS3 and TS4 at their works, according to requirements of Annex 2 (Requirements Specification Document) and Annex 3 (Verification Control Document), namely:

- Performance of vacuum leak test using He leak detector
- Demonstration of pump down to pressure 10^{-6} mbar or lower
- Performance of vacuum cleanliness measurement by Residual Gas Analyzer (RGA) mass-spectrometer to demonstrate residual pressures of molecular compounds according to requirements in Annex 2 to this Contract.

The verification of vacuum and cleanliness performance of the individual elements shall be made according to the Verification Plan. The Supplier shall invite the Client to witness the RGA vacuum cleanliness measurement. The results of vacuum performance verification and testing will be provided in Protocol on Factory Testing of CH3, CH4, CH5, TS3, and TS4.

The support frames SF3A, SF3B, SF4A, SF4B, SF5A and SF5B shall be cleaned according to requirements in Annex 2 to this Contract.

In the subsequent step the Supplier shall prepare for transport of all elements and components manufactured in this Deliverable 3, according to requirements in Annex 2 to this Contract.

For the duration of their transport the chambers and tubing segments shall be hermetically sealed. The initial wrapping of all parts shall be in multiple layers of plastic film (as sheet or bags) with low outgassing rate as specified by requirements in Annex 2 to this Contract. This clean conditions wrapping will be further enclosed in robust outer packaging and transport crates as necessary for protection and handling during shipping to the ELI-Beamlines site.

The Supplier will transport the elements to the ELI-Beamlines facility and will remain responsible for them (with appropriate insurance cover) up to the start of offloading at the ELI-Beamlines Facility loading ramp. Offloading at the ELI-Beamlines building entrance will be made by fork lift truck.

On the ELI-Beamlines site, all delivered elements will be unpacked by the Client in a Class 7 cleanroom and will be inspected for absence of any damage due to transport, according to Annex 3, Verification Control Document (VCD).

The statuses of the verified requirements relevant to D3 and inspection of delivered elements shall be tracked by the Verification Control Document (VCD), see Annex No. 3, and shall be the basis for acceptance of D3.

Completion: 7 months and after Commencement Day

4. Deliverable D4:

Manufacture and factory testing of CH1 and CH2, of their support frames, and of the tubing segment TS1, delivery to ELI-Beamlines

The Supplier shall develop a full set of final production drawings of the chambers CH1 and CH2, of the support frames SF1A, SF1B, SF2A, and SF2B, and of the tubing segment TS1, in line with the documentation produced within the D2 Deliverable.

The Supplier shall manufacture CH1, CH2, SF1A, SF1B, SF2A, SF2B, and TS1, and will perform inspection and testing of vacuum welds according to requirements in Annex 2 (Requirements Specification Document) and Annex 3 (Verification Control Document) of this Contract. The Supplier shall invite the Client for inspecting the testing of vacuum welds.

The chambers CH1 and CH2, and the tubing segment TS1 shall be vacuum cleaned according to requirements in Annex 2 to this Contract. The Supplier shall transport the chambers and the tubing segments into a Class 7 or better cleanroom, where all assembly operations, vacuum performance testing, and vacuum cleanliness verification shall be made.

The Supplier shall provide all equipment for the required vacuum performance and cleanliness testing, namely vacuum pumps, vacuum gauges, He leak detector, and RGA mass spectrometer.

The Supplier shall validate the vacuum performance and vacuum cleanliness of the chambers CH1 and CH2, and of the tubing segment TS1 at their works, according to requirements of Annex 2 (Requirements Specification Document) and Annex 3 (Verification Control Document), namely:

- Performance of vacuum leak test using He leak detector
- Demonstration of pump down to pressure 10^{-6} mbar or lower
- Performance of vacuum cleanliness measurement by Residual Gas Analyzer (RGA) mass-spectrometer to demonstrate residual pressures of molecular compounds according to requirements in Annex 2 to this Contract.

The verification of vacuum and cleanliness performance of the individual elements shall be made according to the Verification Plan. The Supplier shall invite the Client to witness the RGA vacuum cleanliness measurement. The results of vacuum performance verification and testing will be provided in Protocol on Factory Testing of CH1, CH2, and TS1.

The support frames SF1A, SF1B, SF2A, and SF2B shall be cleaned according to requirements in Annex 2 to this Contract.

In the subsequent step the Supplier shall prepare for transport of all elements and components manufactured in this Deliverable 4, according to requirements in Annex 2 to this Contract.

For the duration of their transport the chambers and tubing segments shall be hermetically sealed. The initial wrapping of all parts shall be in multiple layers of plastic film (as sheet or bags) with low outgassing rate as specified by requirements in Annex 2 to this Contract. This clean conditions wrapping will be further enclosed in robust outer packaging and transport crates as necessary for protection and handling during shipping to the ELI-Beamlines site.

The Supplier will transport the elements to the ELI-Beamlines facility and will remain responsible for them (with appropriate insurance cover) up to the start of offloading at the ELI-Beamlines Facility loading ramp. Offloading at the ELI-Beamlines building entrance will be made by fork lift truck.

On the ELI-Beamlines site, all delivered elements will be unpacked by the Client in a Class 7 cleanroom and will be inspected for absence of any damage due to transport, according to Annex 3, Verification Control Document (VCD).

The statuses of the verified requirements relevant to D4 and inspection of delivered elements shall be tracked by the Verification Control Document (VCD), see Annex No. 3, and shall be the basis for acceptance of D4.

Completion: 9 months after Commencement Day



EUROPEAN UNION
European Structural and Investing Funds
Operational Programme Research,
Development and Education



MINISTRY OF EDUCATION,
YOUTH AND SPORTS

ANNEX 2

DETAILED TECHNICAL SPECIFICATIONS OF THE OBJECT OF PURCHASE

Confidentiality Level	<i>BL - Restricted for internal use</i>	TC ID / Revision	00331868/B
Document Status	<i>InReviewProcess</i>	Document No.	N/A
OBS code	<i>912 L2 DUHA Laser</i>		
PBS code	<i>SE.BDS.BT.L2BT.S1, SE.BDS.BT.L2BT.S5</i>		
Project branch	<i>Engineering & Scientific documents (E&S)</i>		
Document Type	<i>Specification (SPE)</i>		

[RSD product category C]

L2 Laser Beam Distribution Vacuum Infrastructure

TP22_011

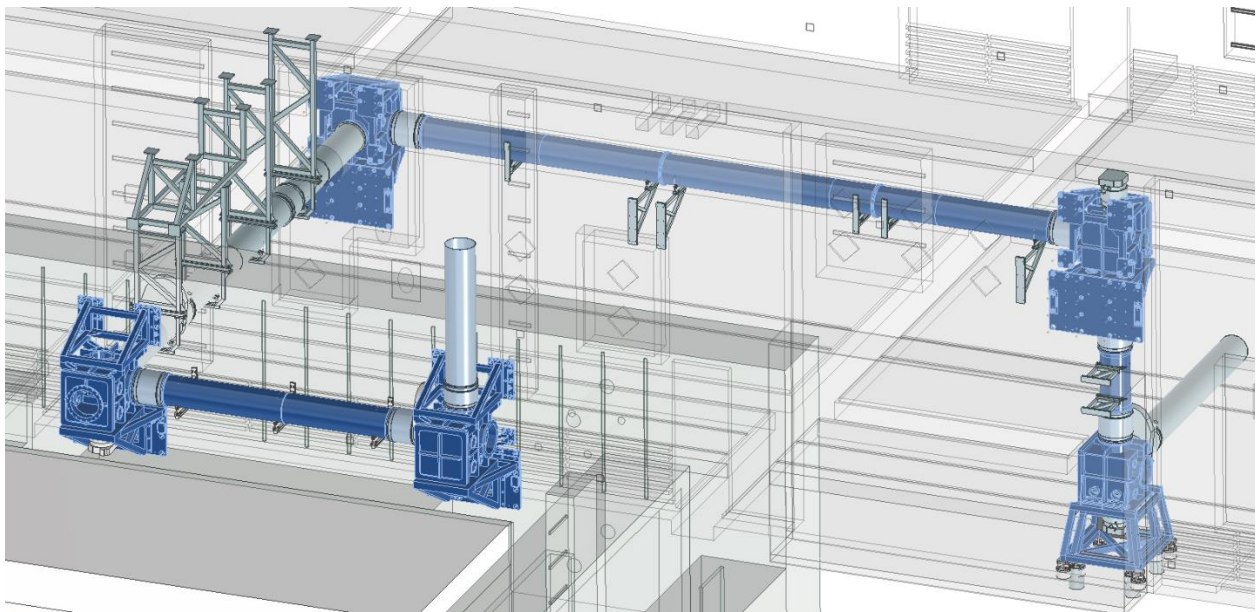

Keywords

N/A

	Position	Name
Responsible person	Head of department of Laser Systems / Senior Scientist	Bedřich Rus
Prepared by	Head of department of Laser Systems / Senior Scientist Senior Optomechanical Designer Mechanical Engineer	Bedřich Rus Jean Claude Lagron Petr Brabeneč

<i>RSS TC ID/revision</i>	<i>RSS - Date of Creation</i>	<i>RSS - Date of Last Modification</i>	<i>Systems Engineer</i>
023912/A.002	02.06.2022	02.06.2022	D. Hanusková

<i>Reviewed By</i>			
<i>Name (Reviewer)</i>	<i>Position</i>	<i>Date</i>	<i>Signature</i>
Pavel Bakule	Group Leader of L1 Allegra Laser/ Deputy of Head of Department		
Lukáš Brabec	Vacuum and Cryogenics Group leader/ Deputy of Head of Department		
Radek Toman	Legal Group Leader		
Andrej Mlích	L2, L3 and L4 Technical Coordinator		
Radek Čípek	Mechanical Engineering Group leader		
Jack Naylor	Group leader of Laser Control Systems		
Daniel Kramer	Group leader of Optical Materials Development		
Jakub Jand'ourek	Building Technology Coordinator		
Tyler Green	Group leader of L2 DUHA		
Alexander Molodzhentsev	Group Leader of LUIS Beamline		
Adam Pokorný	Group Leader of Installations		
Roman Kuřátko	Head of Department of Building Infrastructure and IT		
Veronika Olšovcová	Group Leader of Safety		
Viktor Fedosov	Group Leader of Quality and Planning		

<i>Approved by</i>			
<i>Name (Approver)</i>	<i>Position</i>	<i>Date</i>	<i>Signature</i>
Bedřich Rus	Head of Department of Laser Systems		

<i>Revision History / Change Log</i>				
<i>Change No.</i>	<i>Made by</i>	<i>Date</i>	<i>Change description, Pages, Chapters</i>	<i>TC rev.</i>
1	B. Rus	20.5.2022	RSD draft creation	A
2	D. Hanusková, D. Kramer, B. Rus	25.05.2022	RSD version for review	B
3	D. Hanusková	14.6.2022	RSD final version	C

Table of Content

1. Introduction	4
1.1. Purpose	4
1.2. Scope	4
1.3. Scope of Work.....	4
2. Specific elements of the design	8
2.1. Chambers.....	8
2.1.1. C-rails for utilities and cable trays, preparation for TMP backing vacuum tubing	8
2.1.2. Vacuum flanges	9
2.1.3. Circular flange tolerances	10
2.2. Vacuum chambers flange schedule	10
2.2.1. CH1 vacuum flange schedule	10
2.2.2. CH2 vacuum flange schedule	12
2.2.3. CH3 vacuum flange schedule	14
2.2.4. CH4 vacuum flange schedule	16
2.2.5. CH5 vacuum flange schedule	18
2.3. Support Frames (SF).....	20
2.4. Vacuum Tubing Segments (TS)	21
3. Terms, Definitions and Abbreviations	23
3.1. Reference Documents	24
3.2. References to standards	24
4. Specific contractual requirements.....	25
4.1. Functional, design, material, and manufacture requirements	25
4.2. Cleaning and vacuum performance testing requirements	27
4.3. Packaging and transportation requirements	30
5. Safety Requirements	31
6. Quality requirements.....	31
6.1. Documentation and data control	31
6.2. Nonconformity control system.....	32
7. Verification requirements for the Supplier.....	32
7.1. Verification Control Document (VCD).....	32
7.2. Recommended verification methods	32
7.3. Qualification of Design.....	33
7.4. Manufacturing and delivery	33
7.5. Acceptance	34
8. ANNEX: Drawings.....	35
8.1. RD-01 Drawing package L2 Laser Beam Distribution Vacuum Infrastructure	35

1. Introduction

1.1. Purpose

This Requirements Specification Document (RSD) lists the technical requirements and constraints on a product related to the RA1 program of the ELI-Beamlines project. This can lead to the identification of product interfaces with the ELI Beamlines science-based technology and ELI-Beamlines building facility. This RSD also acts as the parent document for technical requirements that are addressed in lower level design description documents (see section 3.1).

1.2. Scope

The RSD contains all technical requirements: functional and manufacturing design, manufacture, cleaning, packaging and transportation, as well as safety and quality requirements for the following product (tender number: **TP22_011**): **L2 Laser Beam Distribution Vacuum Infrastructure** (“System” in further text, where appropriate).

This RSD states and describes the technical requirements for fabrication of the System which will provide vacuum environment for transporting the L2 200 TW main laser beam from the pulse compressor located in the L2 hall to the E5 experimental hall. The System is designed to permit future extension to make possible transporting the L2 laser beam also to other experimental halls, including E2, E3 and E4, and also E1. Together with the main beam, the System will also enable transporting a small auxiliary mid-IR beam, at the wavelength 2.2 μm , along the same optical path. The laser beam distribution infrastructure consists of five vacuum chambers, of interconnecting tubing, and of supporting structures.

The System is registered in the PBS database under the following PBS codes: **SE.BDS.BT.L2BT.S1**, **SE.BDS.BT.L2BT.S5**.

1.3. Scope of Work

The scope of work includes detailed design, manufacture, testing and transport to ELI-Beamlines of major elements of vacuum infrastructure of the L2 laser beam distribution, interconnecting the L2 beam injector (located in the L2 laser hall) output with the LUIS experimental station in the E5 hall. A schematic layout of the System is in Figure 1.

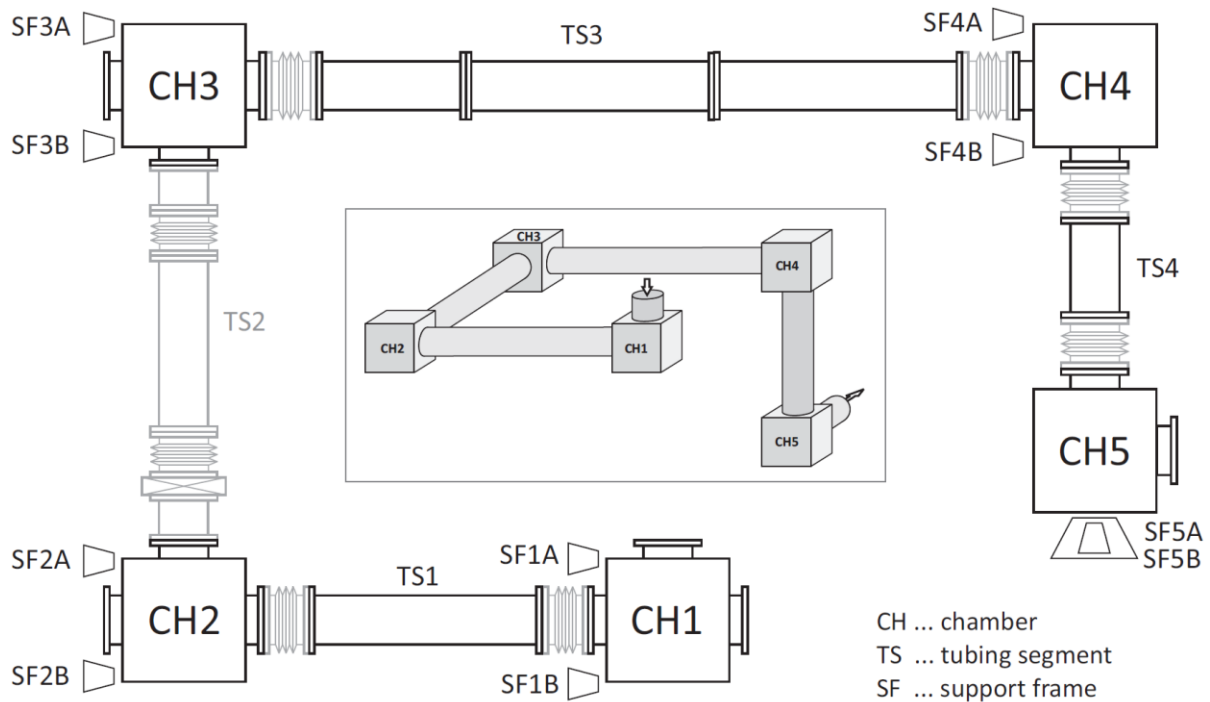

Figure 1: Block scheme of the L2 beam distribution, indicating in black all elements which are within the scope of supply; the axonometric layout is provided as inset. The elements indicated in gray, i.e. bellows and the entire tubing segment TS2, are not included within the scope of supply.

The System involves 5 node chambers which will accommodate plane mirrors reflecting the main 130-mm-in-diameter laser beam, along with the plane mirrors to reflect the auxiliary 38-mm-in-diameter MID-IR beam. Between the node chambers the laser beams propagate in the vacuum tubes with the nominal internal diameter 400 mm.

The overall view of the entire System, involving both parts constituting the Scope of Work of this supply and parts that are already installed or that will be supplied by CA, are in Figure 2. The chambers CH1 to CH4 are suspended on the wall; the CH5 chamber is supported by a chassis mounted on the E5 hall concrete floor. All the five chambers are very similar in design, while the structure of CH1 and CH2, and of CH3 and CH4, are near identical. The chambers CH1 and CH2 are dimensioned so as to be able to accommodate respectively, in future upgrades, a rotational and a translational mirror mount.

The Scope of Work includes the following components:

- Node chambers CH1, CH2, CH3, CH4, and CH5
- Support frames of the chambers SF1A, SF2A, SF3A, SF4A, SF5A
- Support frames of the internal optomechanical tables SF1B, SF2B, SF3B, SF4B, SF5B
- Tubing segments TS1, TS3, and TS4

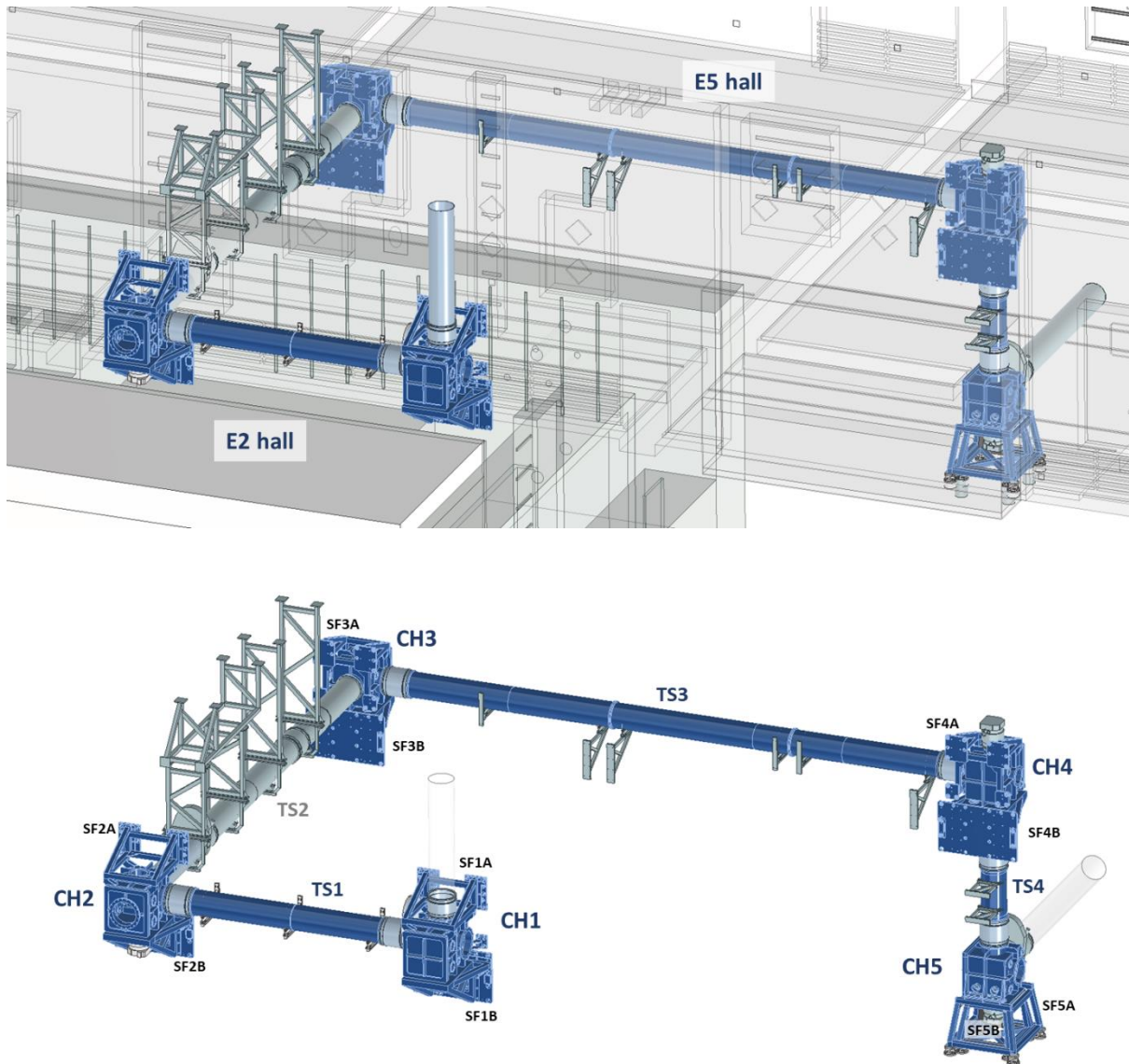

Figure 2: Overall view of the L2 laser beam distribution sector connecting the L2 hall (located above the E2 experimental hall) with the E5 experimental target area of ELI-Beamlines. The chambers CH1 and CH2 will be sited in the E2 hall, and the CH3, CH4 and CH5 will be in the E5 hall. The tubing segment TS2 is already installed and is thus not included in the scope of supply.

All optomechanical components inside the chambers will be mounted on massive aluminium optical tables supported by a stainless-steel bellows legs for de-coupling from the vacuum vessel. The components of the internal structure and the bellows legs are not within the scope of this supply, however the supporting frames SFxB of the internal optomechanical tables and the corresponding flanges on the chambers must fully take into account the design details provided by the CA.

The arrangement of the wall-suspended chambers CH1, CH2, CH3 and CH4 and of their support structures (frames) is shown in

Figure 3. The chamber is attached to the upper support (SFxA) while the lower support (SFxB) serves as an independent platform for the internal optomechanical structure. Both wall supports are affixed to the wall

plates, which are already installed and positioned, with the help of a laser tracker, with a precision better than ± 0.2 mm.

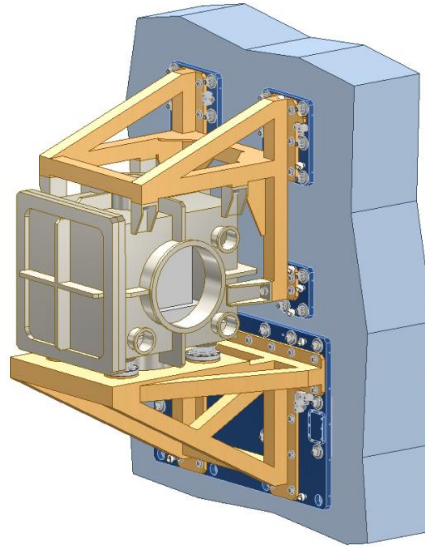

Figure 3: Generic scheme of the wall-suspended node chambers (CH1, CH2, CH3 and CH4). The support frames of the chamber (upper frame) and of the internal optomechanical table (lower frame) are represented in orange; in blue are the wall plates on which the support frames will be mounted. All wall plates are already installed by CA.

All the chambers, their support frames, and the tubing segments shall be manufactured from stainless steel EN 1.4307 (ČSN 17249, equivalent to AISI 304L), or equivalent. Good manufacturing practices for stainless steel welding shall be followed.

Included in the Scope of Work are vacuum sealing for the doors of the chambers, blank flanges and their sealing (stainless steel center ring, fluoroelastomer O-ring, outer Al ring) required to test the chambers at the Supplier and to seal all circular of the chambers and tubing segments for transport. Installation of the chambers, of their support frames and of the tubing segments is not part of the supply.

The chambers are cuboid shaped and are designed as ribbed structures. All chambers are equipped with hinged doors to obtain access for installation and/or servicing the optomechanical mounts and other devices inside the chamber interior.

The Supplier shall develop the advanced conceptual design provided by CA into detail design and subsequently to manufacture documentation. The Supplier shall elaborate design of specific features which are not covered in the CA design, in particular hinges of the chamber doors, and C-profiles for attaching elements of distribution of utilities (backing vacuum for turbomolecular pumps, compressed dry air for venting and for actuation of valves, cooling water) and for attachment of external cable trays on the chambers.

2. Specific elements of the design

In this section specific elements of the design, applying to all subsystems and/or components of the Scope of Work, are described.

2.1. Chambers

The conceptual design of the chambers structures, provided by CA, was optimized by FEM analysis of deformations and stress due to atmospheric pressure differential, so that deformations do not exceed 0.5 mm. The optimization took into account position of specific flanges with respect to spatial constraints (e.g., flanges for illumination and observation of the internal optics) and/or availability of utilities (roughing and backing vacuum, cooling water, and compressed dry air for venting and for actuating vacuum valves) for operation of the chambers. The Supplier is not allowed to modify substantially the structure of the reinforcing ribs, but can locally optimize position and thickness / height of the ribs to improve, if needed, the overall stiffness and to optimize the structure with respect to manufacture. The Supplier shall repeat the FEM analysis of deformations and stress due to atmospheric pressure differential of the final design.

The design of the supports (chassis) and of the wall plates onto which the chambers and optomechanical structures shall be attached were approved by authorized structural engineering office, and the Supplier is not allowed to modify their structure.

All chambers shall be equipped with appropriately located bosses with threads for lifting eyes or device for safe manipulation during transport and installation. Placement of these bosses will be agreed during the Supplier's detailed design phase. The Supplier shall dimension the bosses and threads according to relevant safety standards.

In order to assist positioning of the chamber during installation the external surface shall be equipped with mounting points consisting of bosses with a precisely toleranced $\varnothing 6$ hole suitable for mounting a corner cube reflector for laser scanning. There will be at least three of such bosses on each chamber. Appropriate position of the bosses will be agreed with CA during the manufacturing design process. After manufacture, the supplier shall verify the precise relative position of these bosses with respect to the axes of the principal 400-mm-in-diameter flanges.

The doors of all chambers shall be equipped by stainless steel (class EN 1.4307, equivalent to ČSN 17249, equivalent to AISI 304L, or equivalent) hinges. The hinges will be of double pivot arrangement to avoid crushing the O-rings when closing the door. The design must also ensure that the door does not sag more than 1 mm while opened. The Supplier shall develop detailed design of the hinges. If needed, the doors can be aligned by locating pins providing a guide for closing. Each door shall be equipped with handle for safe manipulation during opening / closing. The design shall allow installation of the hinges and handles on both sides of each door.

All doors shall be equipped with bosses with threads M16 for mounting lifting eyes for manipulation with an overhead crane or with another lifting device.

2.1.1. C-rails for utilities and cable trays, preparation for TMP backing vacuum tubing

The outer side of the chambers shall be equipped by welded sections of rectangular C-rails with size of 28x11 mm (wall thickness 2 mm). The C-rails will serve for affixing stainless steel piping of the utilities, i.e. of the 40-mm-in-diameter tubes of the backing vacuum circuit of the turbomolecular pumps (TMP), of the compressed dry air (CDA) for vacuum valves and for automated venting, and of cooling water for the TMPs. The C-rails will also be used to attach the cable trays for organizing the electrical cables for the TMPs, valves, gauges, etc.

In cooperation with CA, the Supplier shall draw up a line design of the paths of all compressed air and water pipes on each chamber, together with a line design of the primary backing 40-mm-in-diameter vacuum tubing. If appropriate, holes in the chamber ribs shall be made for leading of all these pipes / tubes along the chamber walls. In parallel the Supplier shall also design paths for the electrical cables; the electrical cables will be along the outer structure of the chambers (i.e., not through holes in the ribs). The design will be based on planned use of the individual flanges, as described in Section 2.2 of this document.

The external cable trays will serve to arrange the cables of the active vacuum elements and of motorized actuators from the flanges equipped with feedthroughs (see description of flanges in Section 2.2 Flange Schedule) to the control racks. The path of electrical cables shall be separated from that for the cooling water.

The conceptual design of the paths for utilities and electrical cables, as well as positioning of the C-rails, shall be agreed with CA. It is estimated that for each chamber up to 10 sections of C-rails (in length typically 20 cm per each section) will be needed.

2.1.2. Vacuum flanges

All hinged doors of the chambers shall be vacuum sealed by using a fluoroelastomer O-ring seal. The O-rings shall be located in the doors (i.e., not in the chamber flanges). The O-rings shall be retained in trapezoidal grooves during the lifting of the lids or door opening. The groove shape shall ensure that the O-ring does not come loose while opening the door.

All circular flanges (except custom flanges as specified below in Section 2.2) with diameter larger or equal to 100 mm shall be dimensioned according to ISO 1609 (2014 revision), or equivalent, corresponding to ISO-K or ISO-F implementation. All circular flanges will be sealed by fluoroelastomer O-rings.

All DN400 ISO-F flanges, see Figure 4, shall be equipped by three M6 tapped blind holes (depth 10 mm) on pitch diameter 465 mm, for retaining the O-ring (via the outer ring) during installation.

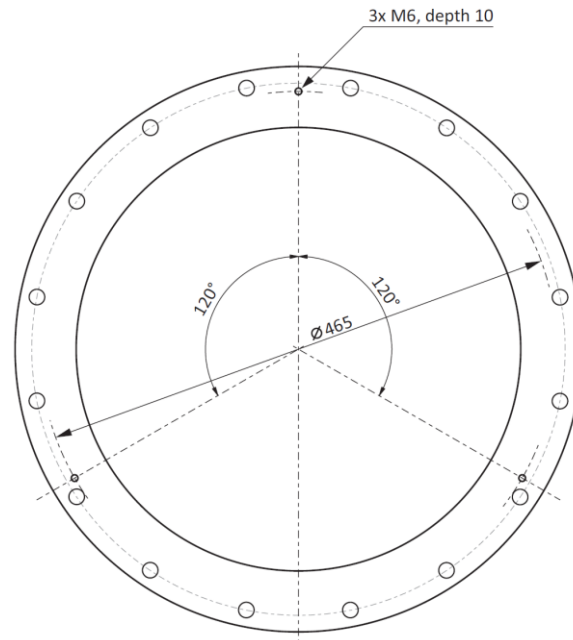

Figure 4: Nominal design of DN400 ISO-F flanges that shall be applied to all flanges of this size on the chambers and on the tubing segments. The three M6 tapped blind holes (on pitch diameter 465 mm) are outside the O-ring and serve to retain the O-ring assembly to ease the installation.

2.1.3. Circular flange tolerances

The alignment of the flanges on the body of the chambers is in some places critical and elsewhere not critical. **Table 1** gives the permitted tolerance for individual tolerance grades applicable to all circular flanges specified for the chambers CH1 to CH5.

All flanges DN400 ISO-F on the chambers and on the tubing segments shall have tolerance grade A.

Flange Tolerance Grade	Tolerance Specification
A	Co-axial tolerance of ± 1 mm or better and angular tolerance of ± 0.5 degrees or better with respect to their ideal axis
B	Co-axial tolerance of ± 3 mm or better and angular tolerance of ± 2.0 degrees or better with respect to their ideal axis
C	Normal manufacturing tolerance (in accordance with ISO 2768-mK)

Table 1: Circular Flange Tolerance Grade.

2.2. Vacuum chambers flange schedule

The vacuum flanges are classified in the following way:

nDx or nFx

where

n Chamber number

- D Door
- F Circular Flange
- x Flange number (within chamber n)

2.2.1. CH1 vacuum flange schedule

The chamber CH1 is designed as stainless steel ribbed structure with thickness of the walls of 10 mm. The chamber is extended in the North-South direction to provide space for accommodation of a rotational mirror mechanism in possible future upgrades. On the North (front) side the chamber is equipped by hinged door with size corresponding to the chamber section (600 x 640 mm). The door will be used for installation of the internal optical table and of the optomechanical and optical components into the chamber interior.

The net size of the CH1 internal space is 600 (w) x 1000 (l/d) x 640 (h) mm³. The total weight of the chamber including the door, without circular blanking flanges, is approximately 571 kg.

The chamber is suspended on the wall by means a chassis mounted on four accurately positioned wall plates.

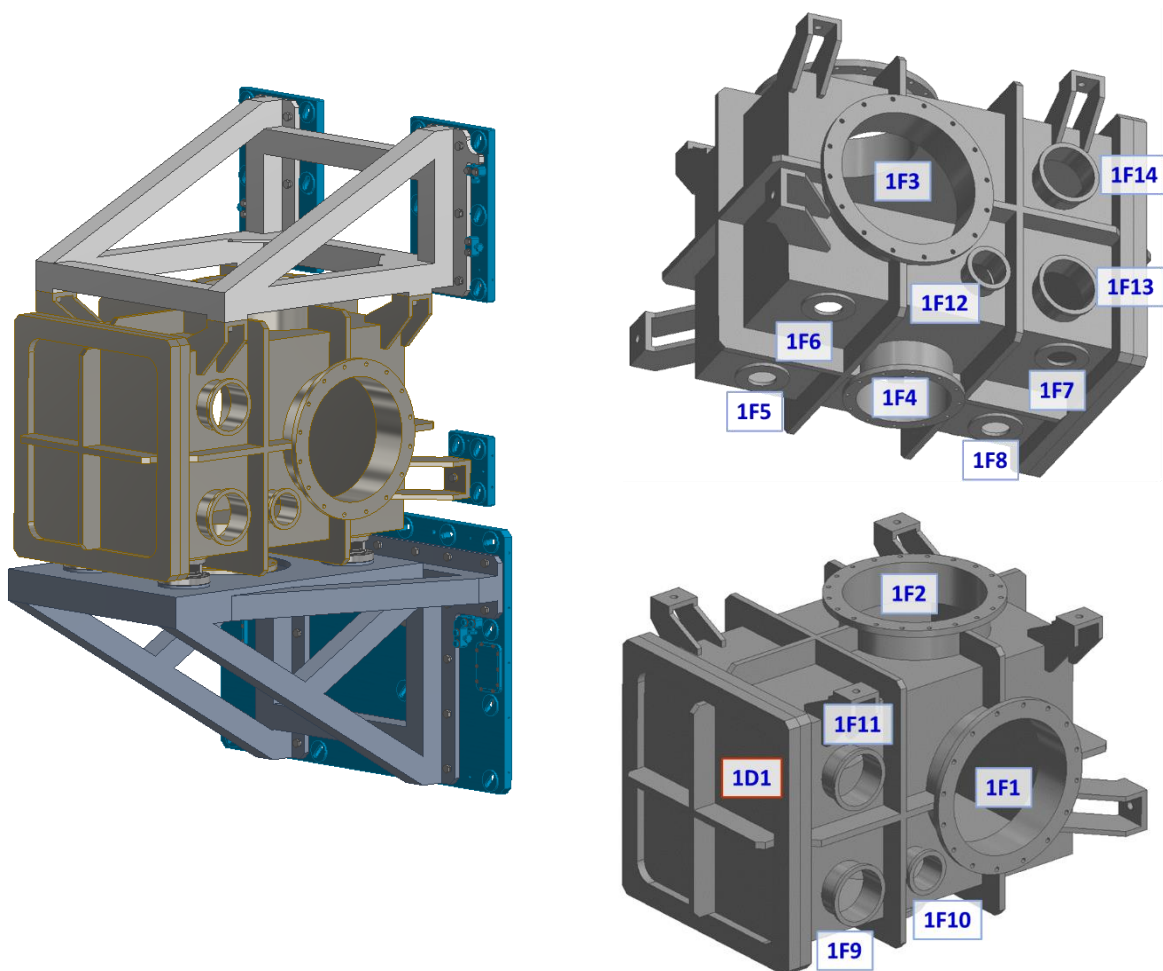

Flange	Size	Position / Purpose	Note	Tolerance
1D1	Rectangular shape, outer size 730 (w) x 770 (h) mm, providing clear opening 600 (w) x 640 (h) mm, 10 mm thickness, ribbed	Door 1, North side of the chamber For installation of the internal optical table and access to the mirror and optomechanics	Sealed by O-ring in a groove in the door Equipped by hinges (possibility of mounting on both sides) Equipped by threads M16 for lifting eyes for manipulation	N.A.
1F1	DN400 ISO-F *	On the west side of the chamber, for future expansion	Will be blanked	A
1F2	DN400 ISO-F *	On top side of the chamber, for incoming laser beam	Will be connected to vacuum tubing through flexible bellows	A
1F3	DN400 ISO-F *	On East side of the chamber, for outbound laser beam, for connecting the TS1 tubing segment	Will be connected to the TS1 vacuum tubing through flexible bellows	A
1F4	DN250 ISO-F *	On underside of the chamber, for TMP	Will be equipped by TMP 3200 l/s	B
1F5	80-mm-diam custom flange	On chamber underside, for connection of bellows isolation of the internal optical table	Tapped holes for connection with the isolation bellows, see Drawing Package. Initially closed by blank flange.	A
1F6	80-mm-diam custom flange	Idem 1F5	Idem 1F5	A
1F7	80-mm-diam custom flange	Idem 1F5	Idem 1F5	A
1F8	80-mm-diam custom flange	Idem 1F5	Idem 1F5	A
1F9	DN160 ISO-K *	On chamber West side, for feedthroughs of electrical cables from the optomechanical mount	Initially closed by blank flange	C
1F10	DN100 ISO-K *	On chamber West side, for venting	Initially closed by blank flange	C
1F11	DN160 ISO-K *	On chamber West side, contingency	Will be blanked	C
1F12	DN100 ISO-K *	On chamber East side, for overpressure burst disk	Initially closed by blank flange	C
1F13	DN160 ISO-K *	On chamber East side, alternative for feedthroughs of electrical cables	Initially closed by blank flange	C
1F14	DN160 ISO-K *	On chamber East side, for plasma cleaning device	Initially closed by blank flange	C

* or equivalent technical solution

2.2.2. CH2 vacuum flange schedule

The chamber CH2 is identical in size and also in the rib structure to CH1, with thickness of the walls 10 mm. Likewise CH1, the CH2 chamber is extended in the North-South direction to provide space for accommodation of a translation mirror mechanism in possible future upgrades. On the North (front) side the chamber is equipped by hinged door with size corresponding to the chamber section (600 x 640 mm), which will be used for installation of the internal optical table and of the optomechanical mount mechanism.

The net size of the CH2 internal space is 600 (w) x 1000 (l/d) x 640 (h) mm³. The total weight of the chamber including the door, without circular blanking flanges, is approximately 566 kg.

The chamber is suspended on the wall by means a chassis mounted on four accurately positioned wall plates.

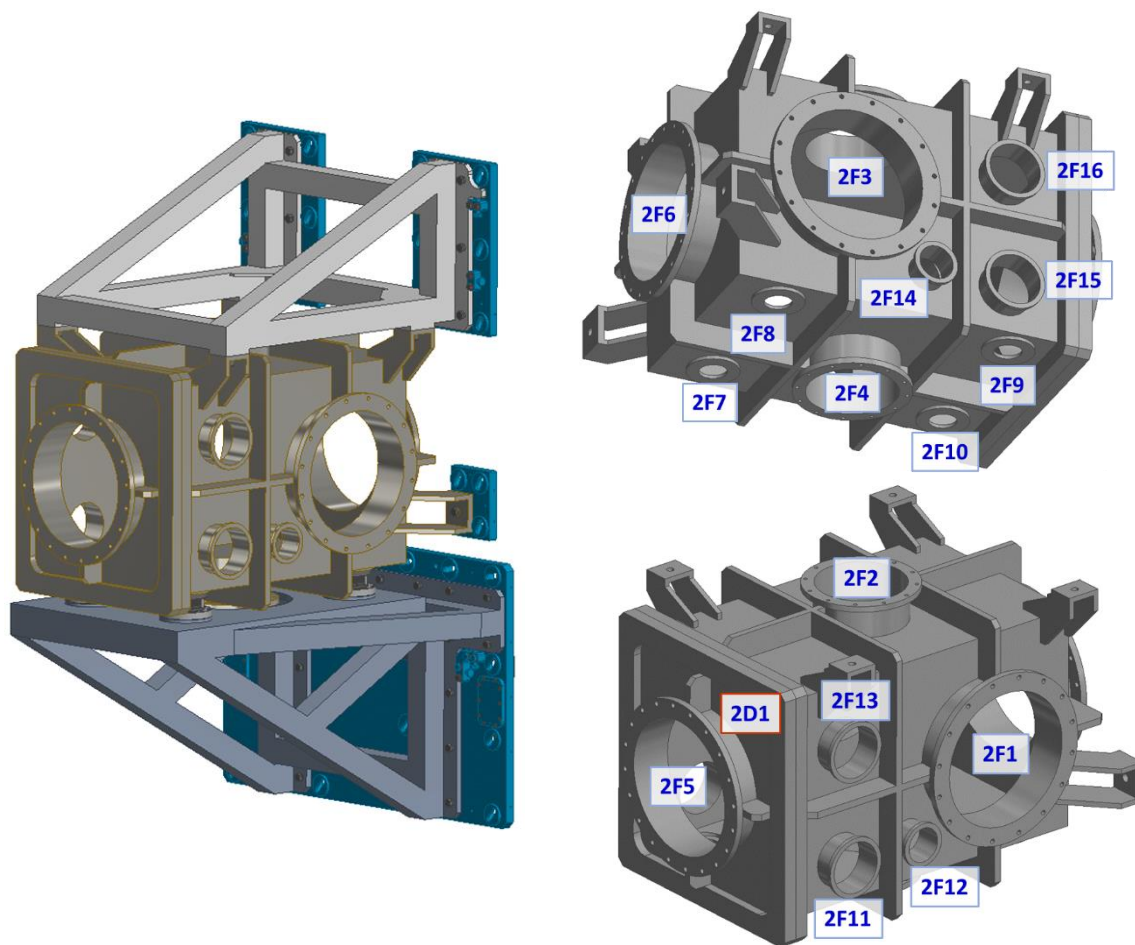

Flange	Size	Position / Purpose	Note	Tolerance
2D1	Rectangular shape, outer size 730 (w) x 770 (h) mm, providing clear opening 600 (w) x 640 (h) mm, 10 mm thickness, ribbed	Door on North side of the chamber For access to the chamber interior and to internal optomechanics	Sealed by O-ring in a groove in the door Equipped by hinges (possibility of mounting on both sides) Equipped by threads M16 for lifting eyes for manipulation	N.A.
2F1	DN400 ISO-F *	On West side of the chamber, for incoming laser beam, for connecting the TS1 tubing segment	Will be connected to the TS1 vacuum tubing through flexible bellows	A
2F2	DN250 ISO-F *	On top of the chamber, alternative for TMP	Will be blanked	B
2F3	DN400 ISO-F *	On chamber South side, for future upgrades	Will be blanked	A
2F4	DN250 ISO-F *	On chamber underside, for TMP	Will be equipped by TMP 3200 l/s	B
2F5	DN400 ISO-F *	On chamber North side on 2D1 door, for alignment purposes or diagnostics of retro-reflected beam	Initially closed by blank flange	A
2F6	DN400 ISO-F *	On chamber back side, for outbound laser beam, for connecting the TS2 tubing segment	Will be connected to the TS2 vacuum tubing	A
2F7	80-mm-diam custom flange	On chamber underside, for connection of bellows isolation of the internal optical table	Tapped holes for connection with the isolation bellows, see Drawing Package. Initially closed by blank flange.	A
2F8	80-mm-diam custom flange	Idem 2F7	Idem 2F7	A
2F9	80-mm-diam custom flange	Idem 2F7	Idem 2F7	A
2F10	80-mm-diam custom flange	Idem 2F7	Idem 2F7	A
2F11	DN160 ISO-K *	On chamber West side, for feedthroughs of electrical cables from the optomechanical mount	Initially closed by blank flange	C
2F12	DN100 ISO-K *	On chamber West side, alternative for venting	Will be blanked	C
2F13	DN160 ISO-K *	On chamber West side, for plasma cleaning device	Initially closed by blank flange	C
2F14	DN100 ISO-K *	On chamber East side, for primary roughing vacuum	Initially closed by blank flange	C
2F15	DN160 ISO-K *	On chamber East side, alternative for feedthroughs of electrical cables	Will be blanked	C

Flange	Size	Position / Purpose	Note	Tolerance
2F16	DN160 ISO-K *	On chamber East side, for RGA	Initially closed by blank flange	C

* or equivalent technical solution

2.2.3. CH3 vacuum flange schedule

The chamber CH3 is designed as stainless-steel ribbed structure with thickness of the walls of 10 mm. On the South side the chamber is equipped by a door with size corresponding to the chamber section (600 x 640 mm). The door will be used for Installation of the internal optical table and of the optomechanical mount into the chamber interior.

The net size of the CH3 internal space is 600 (w) x 760 (l/d) x 640 (h) mm³. The total weight of the chamber including the door, without circular blanking flanges, is approximately 484 kg.

The chamber is suspended on the wall by means a chassis mounted on four accurately positioned wall plates.

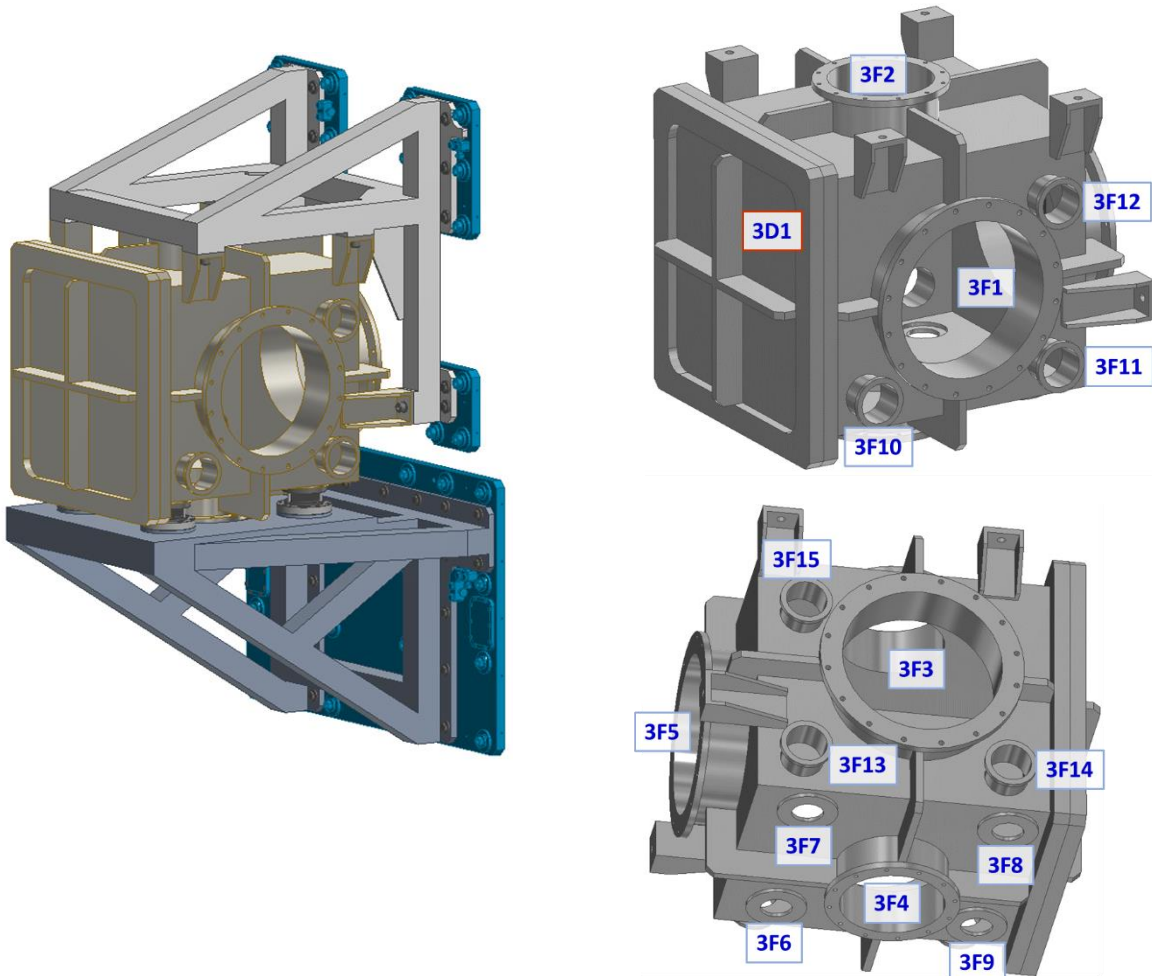

Flange	Size	Position / Purpose	Note	Tolerance
3D1	Rectangular shape, outer size 730 (w) x 770 (h) mm, providing clear opening 600 (w) x 640 (h) mm, 10 mm thickness, ribbed	Door 1 on South side of the chamber For access to the chamber interior and to internal optomechanics	Sealed by O-ring in a groove in the door Equipped by hinges (possibility of mounting on both sides) Equipped by threads M16 for lifting eyes for manipulation	N.A.
3F1	DN400 ISO-F *	On East side of the chamber, for future expansion	Will be blanked	A
3F2	DN250 ISO-F *	On top of the chamber, alternative for TMP	Will be blanked	B
3F3	DN400 ISO-F *	On West side of the chamber, for outbound laser beam, for connecting the TS3 tubing segment	Will be connected to the TS3 vacuum tubing through flexible bellows	A
3F4	DN250 ISO-F *	On underside of the chamber, for TMP	Will be equipped by TMP 3200 l/s	B
3F5	DN400 ISO-F *	On back side of the chamber, for incoming laser beam, for connecting the TS2 tubing segment	Will be connected to the TS2 vacuum tubing	A
3F6	80-mm-diam custom flange	On chamber underside, for connection of bellows isolation of the internal optical table	Tapped holes for connection with the isolation bellows, see Drawing Package. Initially closed by blank flange.	A
3F7	80-mm-diam custom flange	Idem 3F6	Idem 3F6	A
3F8	80-mm-diam custom flange	Idem 3F6	Idem 3F6	A
3F9	80-mm-diam custom flange	Idem 3F6	Idem 3F6	A
3F10	DN100 ISO-K *	On chamber East side, contingency	Will be blanked	C
3F11	DN100 ISO-K *	On chamber East side, for vacuum gauges	Initially closed by blank flange	C
3F12	DN100 ISO-K *	On chamber East side, for plasma cleaning device	Initially closed by blank flange	C
3F13	DN100 ISO-K *	On chamber West side, for feedthroughs of electrical cables from the optomechanical mount	Initially closed by blank flange	C
3F14	DN100 ISO-K *	On chamber West side, for feedthroughs of electrical cables from the optomechanical mount	Initially closed by blank flange	C
3F15	DN100 ISO-K *	On chamber West side, for overpressure burst disk	Initially closed by blank flange	C

* or equivalent technical solution

2.2.4. CH4 vacuum flange schedule

The chamber CH4 is identical in size and in ribbed structure to CH3 while it has differently located the 400-mm-diameter flanges for the laser beam vacuum tubing. On the South side the chamber is equipped by a door with size corresponding to the chamber section (600 x 640 mm). The door will be used for Installation of the internal optical table and of the optomechanical mount into the chamber interior.

The net size of the CH4 internal space is same as of CH3, i.e. 600 (w) x 760 (l/d) x 640 (h) mm³. The total weight of the chamber including the door, without circular blanking flanges, is approximately 490 kg.

The chamber is suspended on the wall by means a chassis mounted on four accurately positioned wall plates.

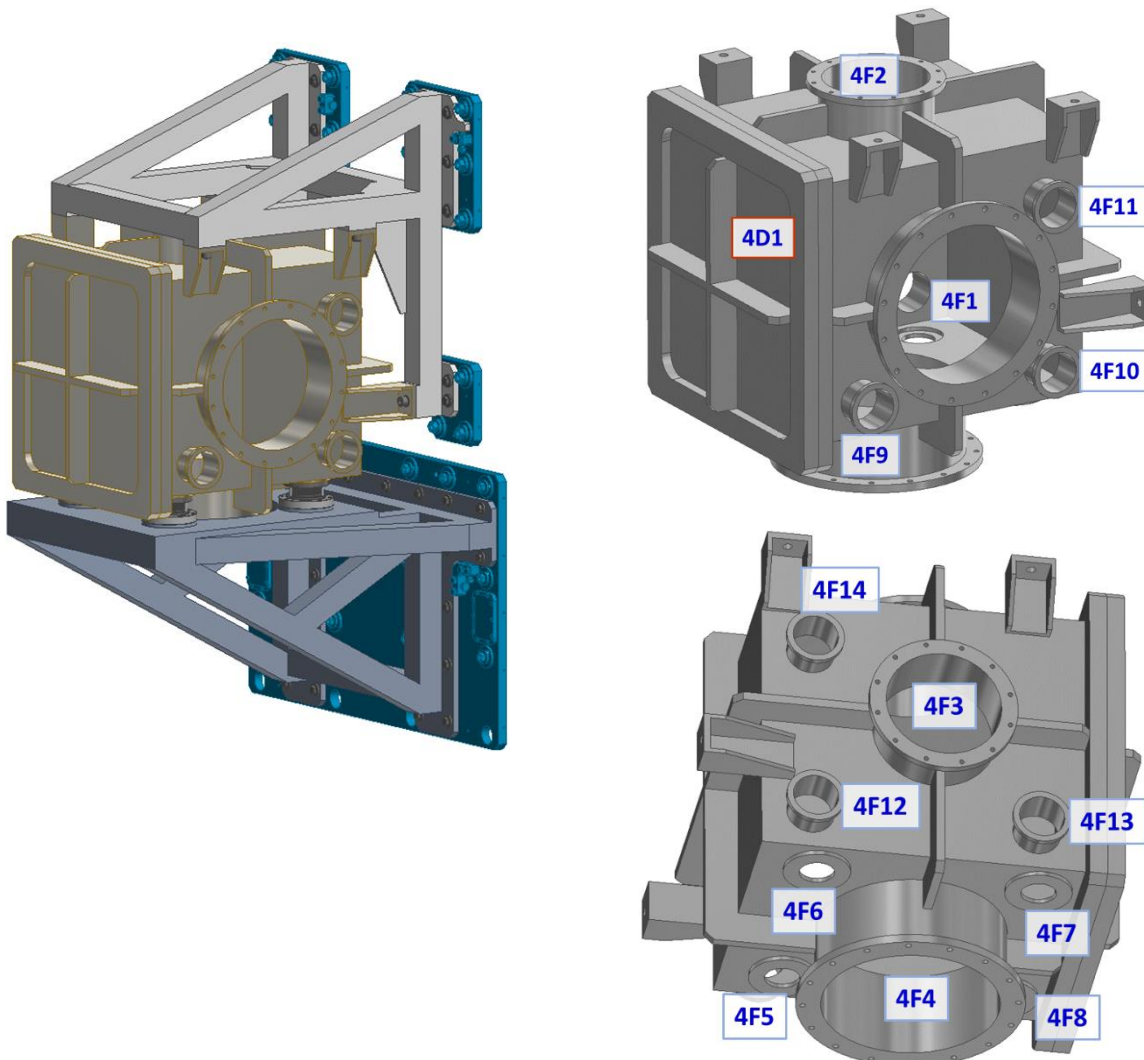

Flange	Size	Position / Purpose	Note	Tolerance
4D1	Rectangular shape, outer size 770 (h) x 730 (w) mm, providing clear opening 640 (h) x 600 (w) mm, 10 mm thickness, ribbed	Door 1 on South side of the chamber For access to the chamber interior and to internal optomechanics	Sealed by O-ring in a groove in the door Equipped by hinges (possibility of mounting on both sides) Equipped by threads M16 for lifting eyes for manipulation	N.A.
4F1	DN400 ISO-F *	On East side of the chamber, for incoming L2 laser beam, for connecting the TS3 tubing segment	Will be connected to the TS3 vacuum tubing through flexible bellows	A
4F2	DN250 ISO-F *	On top of the chamber, alternative for TMP	Will be blanked	B
4F3	DN250 ISO-F *	On West side of the chamber, for TMP	Will be equipped by TMP 3200 l/s	B
4F4	DN400 ISO-K *	On chamber underside, for outbound L2 laser beam, for connecting the TS4 tubing segment	Will be connected to the TS4 vacuum tubing through flexible bellows	A
4F5	80-mm-diam custom flange	On chamber underside, for connection of bellows isolation of the internal optical table	Tapped holes for connection with the isolation bellows, see Drawing Package. Initially closed by blank flange.	A
4F6	80-mm-diam custom flange	Idem 4F5	Idem 4F5	A
4F7	80-mm-diam custom flange	Idem 4F5	Idem 4F5	A
4F8	80-mm-diam custom flange	Idem 4F5	Idem 4F5	A
4F9	DN100 ISO-K *	On chamber East side, for feedthroughs of electrical cables from the optomechanical mount	Will be equipped by flange with cable feedthroughs	C
4F10	DN100 ISO-K *	On chamber East side, for feedthroughs of electrical cables from the optomechanical mount	Will be equipped by flange with cable feedthroughs	C
4F11	DN100 ISO-K *	On chamber East side, for plasma cleaning device	Initially closed by blank flange	C
4F12	DN100 ISO-K *	On chamber West side, for vacuum gauges	Initially closed by blank flange	C
4F13	DN100 ISO-K *	On chamber West side, contingency	Will be blanked	C
4F14	DN160 ISO-K *	On chamber West side, for overpressure bust disk	Initially closed by blank flange	C

* or equivalent technical solution

2.2.5. CH5 vacuum flange schedule

The chamber CH5 is designed as stainless steel ribbed structure with thickness of the walls of 10 mm. On the East side the chamber is equipped by hinged door providing clear opening corresponding to the CH5 internal section (700 x 620 mm), which will serve to installation of the internal optical table and of the optomechanical mirror mount. The laser beam will enter the chamber from above and upon reflection by a mirror will exit to the South.

The net size of the CH5 internal space is 700 (w) x 640 (l/d) x 620 (h) mm³. The total weight of the chamber, without circular blanking flanges, is approximately 460 kg.

The chamber is supported by a trapezoidal-shape chassis the legs of which will be attached to stainless-steel plates bonded to the concrete floor and accurately positioned, with a precision typically ± 0.2 mm. The Supplier shall design and manufacture components of a system for fine-positioning of the chassis of the chamber and also of the chassis supporting the internal optomechanical structure, see Section 2.3.

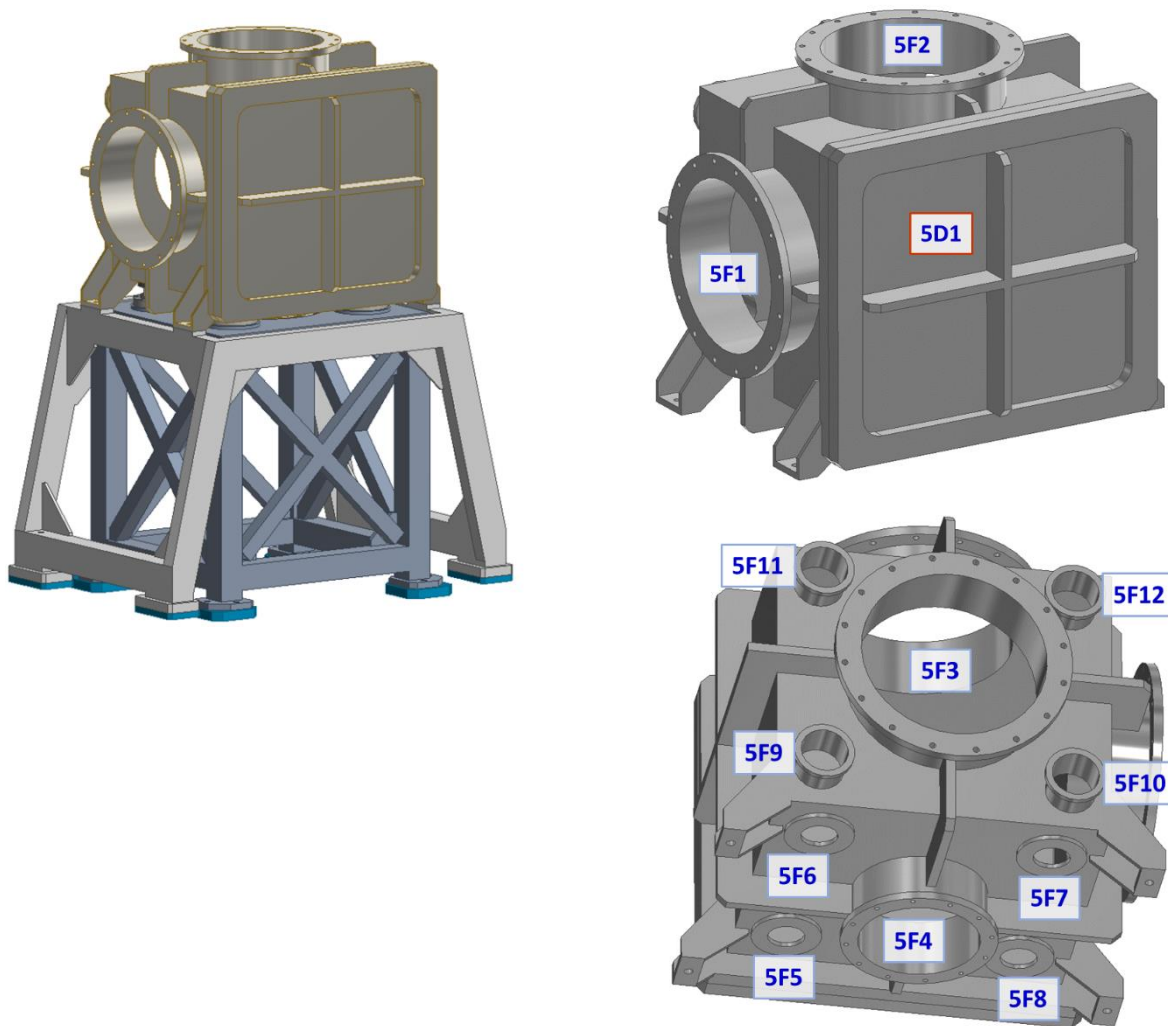

Flange	Size	Position / Purpose	Note	Tolerance
5D1	Rectangular shape, outer size 830 (w) x 750 (h) mm, providing clear opening 700 (w) x 620 (h) mm, 10 mm thickness, ribbed	Door on East side of the chamber For access to the chamber interior and to internal optomechanics	Sealed by O-ring in a groove in the door Equipped by hinges (possibility of mounting on both sides) Equipped by threads M16 for lifting eyes for manipulation	N.A.
5F1	DN 400 ISO-F *	On South side of the chamber, for outbound L2 laser beam	Will be connected to the laser beam vacuum tubing through flexible bellows	A
5F2	DN 400 ISO-F *	On top side of the chamber, for incoming L2 laser beam	Will be connected to the laser beam vacuum tubing through flexible bellows	A
5F3	DN 400 ISO-F *	On chamber West side, for possible future expansion	Will be closed by blank flange	A
5F4	DN250 ISO-F *	On chamber underside, for TMP	Will be equipped by TMP 3200 l/s	B
5F5	80-mm-diam custom flange	On chamber underside, for connection of bellows isolation of the internal optical table	Tapped holes for connection with the isolation bellows, see Drawing Package. Initially closed by blank flange.	A
5F6	80-mm-diam custom flange	Idem 5F4	Idem 5F5	A
5F7	80-mm-diam custom flange	Idem 5F4	Idem 5F5	A
5F8	80-mm-diam custom flange	Idem 5F4	Idem 5F5	A
5F9	DN100 ISO-K *	On chamber West side, for connection to primary roughing vacuum	Initially closed by blank flange	C
5F10	DN100 ISO-K *	On chamber West side, for feedthroughs of electrical cables from the optomechanical mount	Will be equipped by flange with cable feedthroughs	C
5F11	DN100 ISO-K *	On chamber West side, for venting	Initially closed by blank flange	C
5F12	DN100 ISO-K *	On chamber West side, for plasma cleaning device	Initially closed by blank flange	C

* or equivalent technical solution

2.3. Support Frames (SF)

All support frames SFxA and SFxB, both wall-mounted (in case of CH1 to CH4) and floor-mounted (for CH5) shall be made from stainless steel (class 1.4307, equivalent to ČSN 17249, equivalent to AISI 304L, or equivalent). The frames shall be

manufactured from rectangular profiles 80 x 80 mm with 6 mm wall thickness, with the exception of CH5 where several profiles are 50 x 100 mm (thickness 5 mm) and 50 x 50 mm (thickness 6 mm).

The wall-mounted chambers CH1 to CH4 are suspended by a frame which shall be mounted on four already installed wall plates. All plates were accurately positioned using a laser tracker, with a precision better than +/-0.2 mm with respect to their ideal position.

The layout of the plates and of their interfacing with the frames / chassis is shown in Figure 5.

For CH1 and CH2, the upper plates have dimensions 360 (w) x 550 (h) mm and the lower plates are 180 (w) x 220 (h) mm. For CH3 and CH4, the dimensions of the upper plates are 360 (w) x 420 (h) and the lower plates are 220 (w) x 250 (h). The positions of the plates are provided in the drawing documentation. The detailed design of the frames developed by the Supplier shall interface with these wall plates.

The internal optomechanical structures of the wall chambers CH1 to CH4 are supported by a frame that shall be mounted on a large single wall plate with dimensions 1320 (w) x 840 (h) mm; the size of this plate is identical for all the four chambers.

All installed wall plates include a mechanism for fine positioning of the frames upon their initial installation.

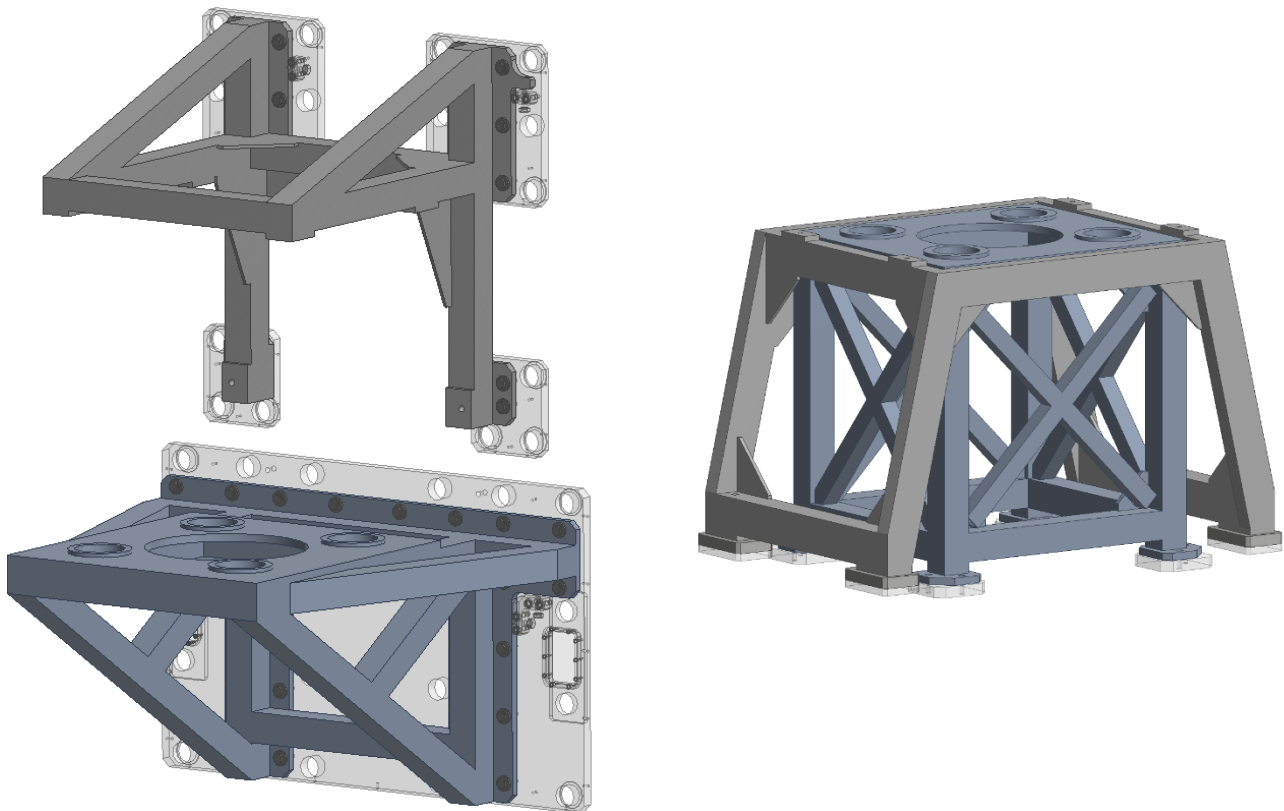

Figure 5: Stainless steel supporting frames of a wall-suspended chamber (left), for CH3 and CH4. In this arrangement the chamber is suspended by the upper frame while the lower frame supports the internal optomechanical structure. The wall plates appearing translucent in the screenshot are already installed. The chassis of the floor-mounted CH5 chamber (right) consists of a trapezoidal outer structure supporting the chamber and of an internal assembly supporting the internal optomechanical table.

The chassis supporting the chamber CH5 as well as the chassis supporting its internal optomechanical structure will be mounted to stainless steel floor plates which are already installed and which are bolted and bonded to the floor. The

floor plates for the chassis of the chamber SF5A have dimensions 120 x 220 mm while the plates for the chassis of the internal optomechanics SF5B are 170 x 170 mm, positioned as indicated in the CH5 drawing documentation. The detailed design of the chassis developed by the Supplier shall interface with the floor plates.

The Supplier shall develop a conceptual design of the CH5 chassis supporting the internal optomechanics to allow access to the space under the chamber, for installation of a turbomolecular pump. This can be achieved, for instance, by using removable bolt-assembled profiles.

2.4. Vacuum Tubing Segments (TS)

The tubing segments TS1, TS3, and TS4 will consist of round tubes with internal diameter 400 mm, see Figure 66. The end flanges of all segments shall be DN400 ISO-F, according to ISO 1609 (2014 revision), or equivalent. The segments shall be made from stainless steel (class 1.4307, equivalent to ČSN 17249, equivalent to AISI 304L, or equivalent).

The tubing segments will be assembled with the chambers CH1 to CH5 using flexible bellows blocks. The vacuum sealing will be made using the standard ISO (or equivalent) centering ring assemblies, consisting of the stainless-steel centering ring, fluoroelastomer O-ring, and of aluminium outer ring. These sealing assemblies are not within the scope of supply of this contract.

The length of the flexible vacuum bellows blocks, in the working state, is 435 mm (distance between flange front faces). The Supplier shall verify (and, if necessary, adjust) the lengths of the individual tubes to correspond to the principal geometry of the L2 laser beam distribution as defined in this document, accounting for the thickness of the O-ring assembly and taking into account the centering rings net thickness 5.6 mm for DN400 flanges (according to ISO 1609 / 2014 revision, or equivalent).

All tubing segments shall be equipped on the top by round lumps with threads M16 for lifting eyes to be used during installation and/or manipulation.



Figure 6: Generic example of the stainless steel vacuum tubing segments (lumps with threads for lifting eyes not shown).

The essential parameters of the individual tubing segments are in Table 2. The Supplier shall verify by FEM simulations the deformations of the segments under the vacuum pressure differential. The Supplier is allowed to modify thickness of the tube walls and /or to implement circumferential ring(s) to reinforce the stiffness, to achieve deformations not exceeding 1 mm anywhere on the tube.

Table 2: List of the Tubing Segments and their parameters.

Tubing Segment No	Nominal length (mm)	Note
TS1	3,271	400 mm internal diameter, minimum 3 mm wall thickness, terminated by DN400 ISO-F (or equivalent) flanges, according to Section 2.1.3
TS2	N.A.	<i>Already installed, not required within this contract</i>
TS3	8,850	Consisting of three tubes with lengths: a) 1,655 mm b) 4,630 mm c) 2,553 mm All three tubes with 400 mm internal diameter, minimum 3 mm wall thickness, terminated by DN400 ISO-F (or equivalent) flanges, according to Section 2.1.3
TS4	1,897	Consisting of two tubes (separated by bellows provided by CA) with lengths: a) 800 mm, rectangular cross section with internal dimensions 280 x 280 mm, 10 mm wall thickness b) 650 mm, 400 mm internal diameter, minimum 3 mm wall thickness Both tubes terminated by DN400 ISO-F (or equivalent) flanges, according to Section 2.1.3

3. Terms, Definitions and Abbreviations

For the purpose of this document, the following abbreviated terms are applied:

Abbreviation	Meaning
A	Analysis (as a verification method)
AMU	Atomic Mass Unit
BT / BD	Beam Transport / Beam Distribution
CA	Contracting Authority (Institute of Physics CAS, FZU in Czech)
CDA	Compressed Dry Air
CH	(CH1 to CH5) chambers
DN	Diameter Nominal (for vacuum flanges)
ELI	Extreme Light Infrastructure
FEM / FEA	Finite Element Method / Finite Element Analysis
FTR	Factory Test Report
FZU	Fyzikální ústav, v.v.i. (Institute of Physics CAS, public research institution)
I	Inspection (as a verification method)
ISO	International Organization for Standardization
ISO-KF	Type of vacuum flanges
ISO-F	Type of vacuum flanges
L2	Identification code of ELI-Beamlines laser
L2, E5	Identification code of ELI-Beamlines hall
NCR	Nonconformity Report
NVR	Non-Volatile Residue

Abbreviation	Meaning
PE	Polyester
RA1	Research activity 1
RGA	Residual Gas Analyzer
RSD	Requirements Specification Document
SEM	Secondary Electron Multiplier
SF	Support Frame
T	Test (as a verification method)
TC ID	TeamCenter IDentifier (unique identifier number)
TS	Tubing Segment
TMP	TurboMolecular Pump
UHV	Ultra High Vacuum
VCD	Verification Control Document
VR	Verification Report

3.1. Reference Documents

Number of document	Title of Document/ File
RD-01	Drawing package L2 Laser Beam Distribution Vacuum Infrastructure

Detailed list of documentation included within **RD-01** archive:

Drawing No	Filename	File format
1	L2 Beam Distribution Overview	pdf
2	Chamber CH1 Assembly	pdf
3	Chamber CH1 with support frame SF1A	pdf
4	Support Frame of Optomechanical Structure SF1B	pdf
5	Chamber CH2 Assembly	pdf
6	Chamber CH2 with Support frame SF2A	pdf
7	Support Frame of Optomechanical Structure SF2B	pdf
8	Chamber CH3 Assembly	pdf
9	Chamber CH3 with support frame SF3A	pdf
10	Support Frame of Optomechanical Structure SF3B	pdf
11	Chamber CH4 Assembly	pdf
12	Chamber CH4 with support frame SF4A	pdf
13	Support Frame of Optomechanical Structure SF4B	pdf
14	Chamber CH5 Assembly	pdf
15	Chamber CH5 with support frame SF5A	pdf
16	Support Frame of Optomechanical Structure SF5B	pdf
17	TS1 Vacuum Tube	pdf

18	TS3-A Vacuum Tube	pdf
19	TS3-B Vacuum Tube	pdf
20	TS3-C Vacuum Tube	pdf
21	TS4-A Vacuum Tube	pdf
22	TS4-B Vacuum Tube	pdf

An overview of the **RD-01** reference drawing related to the L2 Laser Beam Distribution Vacuum Infrastructure is shown in Section 8.

3.2. References to standards

If this document includes references to standards or standardized / standardizing technical documents the CA allows/permits also another equal solution to be offered. If a supplier offers another equal solution the CA shall not reject its bid, once the supplier by appropriate means in the bid proves that the offered supplies, services or works meet in an equivalent manner all the contractual requirements including references to standards or technical documents

4. Specific contractual requirements

The following sections of this specification provide a summary of the specific contractual requirements. The total scope of the contract also comprises all the requirements stated or implied in the foregoing text, whether or not included in the summaries.

4.1. Functional, design, material, and manufacture requirements

- REQ-034340/A **R1-01**
 All elements of the System shall be detail designed and manufactured according to the requirements described herein and in **RD-01** assembly drawings (see also Section 3.1).
 Verification method: R - Review of design, T – Test, I – Inspection
- REQ-034341/A **R1-02**
 The Supplier shall develop detail design of the O-ring arrangement in the doors, including trapezoidal grooves ensuring that the O-rings do not come loose while opening the door. The design shall also allow the O-rings to be easily replaced.
 Verification method: R - Review of design
- REQ-034342/A **R1-03**
 The Supplier shall develop design of door hinges with double pivot arrangement to avoid crushing the O-rings when closing the door. The doors shall not sag more than 1 mm while opening.
 Verification method: R - Review of design, T – Test
- REQ-034343/A **R1-04**
 For each chamber the Supplier shall design, using instructions from CA, paths (on the outer surface of the chambers) for the utilities, primary backing vacuum and electrical cables for the vacuum elements and for motorized actuators, based on description of purpose of the flanges in Section 2.2.
 Verification method: R - Review of design
- REQ-034344/A **R1-05**
 Based on the approved design of paths for utilities (R1-04), primary backing vacuum and electrical cables, the Supplier shall develop corresponding design of cable trays and mounting C-rails, as well as holes in the ribs for the utilities and primary backing vacuum.
 Verification method: R - Review of design
- REQ-034345/A **R1-06**
 The Supplier shall develop design of the tubing segments, verifying that the tube lengths upon assembly with O-rings and flexible bellows correspond to the defined geometry of the system.
 Verification method: R - Review of design
- REQ-034346/A **R1-07**
 The detailed design shall make all necessary allowance for transport of the chambers and tubing segments to their working locations. This shall include provision of designated lifting and jacking points. Similarly the doors shall be equipped with lifting features (e.g. bosses for screw-in lifting eyes) to enable their handling by overhead crane.
 Verification method: R - Review of design, I – Inspection

- REQ-034347/A **R1-08**
 All DN400 ISO-F flanges shall be manufactured in accordance with Section 2.1.2 of this document.
 Verification method: R - Review of design, I – Inspection
- REQ-034348/A **R1-09**
 All DN400 ISO-F flanges on the chambers and on the tubing segments shall have Tolerance Grade “A” (see Section 2.1.3), i.e. co-axial tolerance of ± 1 mm or better and angular tolerance of ± 0.5 degrees or better with respect to their ideal axis, for reasons of critical geometry.
NOTE: The required tolerance band for each flange is specified in Section 2.2.
 Verification method: R - Review of design, T- Test, I – Inspection
- REQ-034349/A **R1-10**
 All 80-mm-diameter custom flanges on underside of the chambers shall have Tolerance Grade “A” (see Section 2.1.3), i.e. co-axial tolerance of ± 1 mm or better and angular tolerance of ± 0.5 degrees or better with respect to their ideal axis, for reasons of critical geometry.
 Verification method: R - Review of design, T- Test, I – Inspection
- REQ-034350/A **R1-11**
 The chambers and the vacuum tubing segments shall be designed and manufactured for vacuum level of 10^{-7} mbar or better.
 Verification method: R – Review of design, T – Test
- REQ-034351/A **R1-12**
 For all chambers and tubing segments the Supplier shall perform FEM analysis of the final design to demonstrate structural stability resulting in deformations of walls less than 0.5 mm upon pump down from atmospheric pressure.
 Verification method: R – Review
- REQ-034352/A **R1-13**
 The Supplier shall provide **Certificate of Origin** specifying manufacturer and composition of the raw material, for all components of the supply.
 Verification method: R - Review
- REQ-034353/A **R1-14**
 The outer side of the chambers shall be equipped by welded sections of C-rails as resulting from the design process, see REQ-034344/A **R1-05**.
 Verification method: R - Review of design, I – Inspection
- REQ-034354/A **R1-15**
 The outer side of the chambers shall be equipped with mounting points consisting of bosses for a corner cube reflector for laser scanning. The exact positions of these bosses shall be agreed with CA.
 Verification method: R - Review of design, I – Inspection
- REQ-034355/A **R1-16**
 The engineering drawings and detailed 3D models shall be approved by CA.
 Verification method: R - Review of design
- REQ-034356/A **R1-17**
 All welds shall be visually inspected by the Supplier, and protocol for each chamber and tubing segment shall be issued.
 Verification method: I – Inspection

- REQ-034357/A **R1-18**
 All testable vacuum welds on the chambers and on the tubing segments shall be inspected by ultrasonic probe, and protocol for each chamber and tubing segment will be issued.
 Verification method: I – Inspection
- REQ-034358/A **R1-19**
 All inner vacuum surfaces shall have roughness Ra=0.8 µm or better (i.e. smaller). If grinding is used to achieve this finish, the following rules shall apply:
 - prior the grinding the cleaning procedure involving degreasing, rinsing and drying, described in REQ-034364/A **R2-02** shall be used;
 - the grinding process shall not involve any abrasive paste or abrasive medium that can embed into the surface.
NOTE: the cleaning procedure described in REQ-034364/A R2-02 can be complemented, before grinding, by laser cleaning. If such procedure is to be applied, details shall be first approved in writing by the CA.
 Verification method: R - Review of design, I - Inspection
- REQ-034359/A **R1-20**
 The outer surface of the chambers and of the tubing segments shall be glass bead blasted.
 Verification method: R – Review of design, I – Inspection
- REQ-034360/A **R1-21**
 The surface of the support frames shall be glass bead blasted.
 Verification method: R – Review of design, I – Inspection
- REQ-034361/A **R1-22**
 The Supplier shall check all major dimensions of the manufactured chambers and tubing segments, as defined in the engineering drawings approved by CA (see also REQ-034355/A **R1-16**). The result shall be provided in the form of the Factory Test Reports.
 Verification method: R – Review, T – Test (M – Measuring)
- REQ-034362/A **R1-23**
 The Supplier shall dimension, by means of FEM analysis, the vacuum flanges DN250 ISO-F (or equivalent) assigned to turbomolecular pumps (see Section 2.2 Vacuum chambers flange schedule) to be able to withstand the torque 60 kNm in the event of a crash of the pump.
 Verification method: R – Review of report

4.2. Cleaning and vacuum performance testing requirements

- REQ-034363/A **R2-01**
 Before final treatment on inner vacuum surfaces of each chamber and each tubing segment, especially if grinding is used for surface finish, the Supplier shall invite CA to perform inspection of the surface cleanliness (see REQ-034358/A **R1-19**).
 Verification method: I – Inspection
- REQ-034364/A **R2-02**
 All finished stainless steel parts of the chambers and tubing segments shall be degreased by thorough cleaning with high pressure hot water jet (>120 bar), using appropriate high-performance detergent (e.g. 2% solution of General Purpose Cleaner/Degreaser mixture of Sodium Tripolyphosphate - 3 - < 5%, Modified Polyether Anionic Surfactant - 1 - < 3%, Non-ionic surfactant 1 - < 3%; pH >11; (5 - 15% - Non-ionic Surfactants, 1 - 5% - Phosphates, 1 - 5% - Anionic Surfactants) or equivalent), at a temperature

between 70°C and 75°C, for no less than 5 minutes /m². The water jet strokes shall form a cross pattern on the cleaned surface. Subsequently, the parts shall be immediately, without letting the surface to dry, rinsed with hot demineralised water with at least 75°C.

The previous step, i.e. thorough cleaning with high-pressure water with appropriate high-performance detergent, followed by rinsing in demineralised water without letting the surface to dry, shall be repeated.

Subsequently, the parts shall be dried by clean pressure gas (e.g. nitrogen) in a way not leaving traces of residues from water drops.

It is not allowed to use wipes wetted with isopropanol or acetone after completion of the above procedure.

Spraying or flushing of parts of vacuum surfaces by ultraclean acetone (<5ppm evaporation residue) is allowed, provided it does not come into contact with any plastic parts such as squirt bottles or O-rings.

Dry wiping of smooth surfaces with polyester wipes to minimize particle contamination is allowed.

NOTE: Initial gross cleaning step depending on the status of the parts after machining is allowed. Using polyester wipes soaked in clean organic solvent (i.e. acetone) is possible before precision cleaning.

NOTE: Use of specific degreasing solution shall be approved in writing by CA. The CA also permits another equivalent cleaning procedure to be offered, however this shall be approved in writing by the CA.

NOTE: A possible additional step may involve cleaning by laser or by manual electro-polishing with 10% solution of H₃PO₄. If any of these techniques is used, detailed steps of the procedure shall be agreed in writing with CA.

Verification method: R – Review, I – Inspection

REQ-034365/A

R2-03

All O-rings shall be made from fluoroelastomer and shall be vacuum baked in a clean oven at temperature of 120°C for 48 hours prior to use. After the bake-out, the O-rings shall not come in contact with isopropyl alcohol or any grease.

NOTE: CA recommends ultrasonic cleaning in deionized water for at least 10 minutes prior to the bake-out procedure.

Verification method: I – Inspection

REQ-034366/A

R2-04

After final cleaning (REQ-034364/A **R2-02**) the Supplier shall assemble each chamber and each tubing segment in ISO 7, (ISO 14644-1:2015, equivalent Class 10,000, FS 209E) or better cleanliness class cleanroom and shall vacuum test the assembled chambers and tubing segments with blank flanges, bolting and O-rings which shall be part of the supply. The tests shall be performed according to **R2-06**, **R2-07**, and **R2-08**.

Verification method: R – Review, T – Test, I – Inspection

REQ-034367/A

R2-05

Only new ISO blank flanges, clamps, and O-ring assemblies shall be used.

Verification method: I – Inspection

REQ-034368/A

R2-06

The Supplier shall test the evacuated chambers and tubing segment for deformations due to the atmospheric pressure differential. The measured deformations shall not exceed 0.5 mm at any location. The result shall be provided in the form of the Factory Test Report.

Verification method: R – Review, T – Test, I – Inspection

REQ-034369/A

R2-07

The Supplier shall perform vacuum leak test of each chamber and of tubing segment, using a helium leak detector. The measured single leak rate of any flange shall be less than 1×10^{-8} mbar·l/sec. The total leakage rate of each chamber shall be less than 1×10^{-3} mbar·l/sec. The results shall be provided in the form of the Factory Test Report.

NOTE: It is recommended that the single flange test (helium spray) shall be performed according to ČSN EN 1779, method A.3, and the test of total leakage according to ČSN EN 1779, method D.2.

Verification method: R – Review, T – Test, I – Inspection

REQ-034370/A

R2-08

The Supplier shall perform mass-spectrometer RGA (Residual Gas Analyzer) vacuum cleanliness test on each chamber and on each tubing segment. The RGA shall have a range of at least 200 AMU (Atomic Mass Unit) and shall contain Secondary Electron Multiplier (SEM).

The Supplier shall invite CA to witness performance of the vacuum cleanliness mass-spectrometer RGA test.

The chamber or tubing segment shall be pumped by a dry vacuum pump and a turbomolecular pump to a pressure of 10^{-6} mbar for at least 12 hours before activating the RGA. The RGA filament shall be on for at least 4 hours before recording the final scan. The resulting RGA spectrum shall conform to the following criteria:

- a) all peaks above AMU 45 shall be lower than 1/100 of AMU 44;
- b) the AMU 45 peak shall be lower than 1/10 of AMU 44.

Verification method: R – Review, T – Test, I – Inspection

REQ-034371/A

R2-09

All finished supporting stainless steel frames shall be degreased by thorough cleaning with high pressure hot water jet (>120 bar), using appropriate high-performance detergent (e.g. 2% solution of General Purpose Cleaner/Degreaser mixture of Sodium Tripolyphosphate - 3 - < 5%, Modified Polyether Anionic Surfactant - 1 - < 3%, Non-ionic surfactant 1 - < 3%; pH >11; (5 - 15% - Non-Ionic Surfactants, 1 - 5% - Phosphates, 1 - 5% - Anionic Surfactants) or equivalent), at a temperature between 70°C and 75°C, for no less than 5 minutes /m². The water jet strokes shall form a cross pattern on the cleaned surface. Subsequently, the parts shall be immediately, without letting the surface to dry, rinsed with hot demineralised water with at least 75°C.

The previous step, i.e. thorough cleaning with high-pressure water with appropriate high-performance detergent, followed by rinsing in demineralised water without letting the surface to dry, shall be repeated.

Subsequently, the parts shall be dried by clean pressure gas (e.g. nitrogen) in a way not leaving traces of residues from water drops.

Verification method: R – Review, I – Inspection

4.3. Packaging and transportation requirements

- REQ-034372/A R4-01**
 The Supplier shall invite CA to inspect the vacuum cleanliness of each chamber and tubing segment in ISO 7 (or better) cleanroom before starting the packaging of these components for transport. The results of the inspection shall be recorded in the form of the Vacuum Cleanliness Inspection Report.
 Verification method: I – Inspection
- REQ-034373/A R4-02**
 All chambers shall be prepared for transport with the side doors fitted, and with all ISO circular flanges mounted. The flanges for the optomechanical legs on the underside of the chambers will be sealed by metal blanks cleaned to the same standard as the chambers.
 Verification method: I – Inspection
- REQ-034374/A R4-03**
 The vacuum tubing segments shall be prepared for transport with the front flanges sealed by metal blanks which will be cleaned to the same standard as the segments.
 Verification method: I – Inspection
- REQ-034375/A R4-04**
 The cleaned chambers and tubing segments shall be wrapped in two layers of ultra-low outgassing polyethylene film (as sheet or bags) with thickness of at least 100 µm, with NVR (non-volatile residue) better than 0.15 µg/cm² and very low particle generation. The foil type to be used for the wrapping shall be approved by CA. Alternatively, UHV compatible aluminium foil approved by CA can be used. The clean conditions wrapping shall be further enclosed in robust outer packaging and transport crates as necessary for protection and handling during shipping to the ELI-Beamlines site.
NOTE: The CA can recommend to the Supplier appropriate low-outgassing polyethylene-base foils brands if required.
 Verification method: R – Review, I – Inspection
- REQ-034376/A R4-05**
 The vacuum chambers and tubing segments shall be packed separately for transport.
 Verification method: I – Inspection
- REQ-034377/A R4-06**
 The Supplier shall transport the completed and tested components to the ELI Beamlines site.
NOTE: The bid price will be considered by the CA as the final price, including transportation costs.
 Verification method: R – Review, I – Inspection
- REQ-034378/A R4-07**
 The transportation procedure shall be reviewed and agreed by the CA.
 Verification method: R - Review
- REQ-034379/A R4-08**
 The Supplier shall allow supervision by the CA of the activities related to the transportation.
NOTE: Any acts of supervision shall not mean that the CA assumes additional liability of any kind exceeding its liabilities according to the contract.
 Verification method: R - Review
- REQ-034380/A R4-09**
 All flanges of the chambers and tubing segments shall remain sealed during transport.
 Verification method: R - Review, I – Inspection

5. Safety Requirements

- REQ-034381/A **R5-01**
 The Supplier shall supply a **Declaration of Conformity** (DoC) for each product type if the appropriate legislation determines the Supplier's obligation to have a DoC for the purposes of a Device sale in the Czech Republic. In such a case the DoC shall comply with:
- Act No. 90/2016 Coll., as amended
 - Act No. 20/1997 Coll., as amended
 - The equivalent legal regulation of another EU member state so that the conditions for the sale of the product in the Czech Republic are met, and/or
 - the relevant EU/EC regulation
- NOTE: The compliance with these obligations will be demonstrated by the (EU/EC) DoC, other relevant documents and the CE/CCZ marking.*
- Verification method: R – Review
- REQ-034382/A **R5-02**
 The Supplier shall perform **risk assessment** of the delivered products in order to ensure safe transportation, installation and their further use for the assembly of the entire system. The results of the risk assessment shall be reflected in the technical documentation (REQ-034383/A and REQ-034385/A).
- Verification method: R – Review

6. Quality requirements

6.1. Documentation and data control

- REQ-034383/A **R6-01**
 The Supplier shall supply the following relevant engineering documents:
- **engineering design** including detailed **3D model(s)**, full set of **detailed engineering drawings**, and **design** supporting documentation approved by CA
 - full **technical documentation** on the delivered Product (e.g. storage, installation, safe operation and maintenance instructions);
 - all “**requests for deviation/waiver** from requirements described herein” approved by CA (see REQ-034386/A).
- Verification method: R – Review, I - Inspection
- REQ-034384/A **R6-02**
 The Supplier shall use following data formats:
- *.JPG, *.PNG, *.TIFF, *.PDF/A, *.HTML
 - CAD 2D: *.dwg
 - CAD 3D: *.stp; *.ste; *.step or other 3D CAD formats agreed with the CA
 - text processors *.doc, *.docx, OpenDocument Format
 - spreadsheet processors *.xls, *.xlsx, OpenDocument Format
 - presentations *.ppt, *.pptx; OpenDocument Format
- REQ-034385/A **R6-03**
 Documentation (e.g. reports, protocols, certificates, instructions, manuals, etc.) shall be supplied in PDF format and hardcopy.

6.2. Nonconformity control system

REQ-034386/A **R6-04**

The Supplier shall establish and maintain a nonconformity control system compatible with ČSN EN ISO 9001 (or equivalent, e.g. EN ISO 9001).

7. Verification requirements for the Supplier

The verification process will be performed mostly by the Supplier. The VCD draft provided by CA will specify exactly what is required to be verified by whom as well as the CA proposal how.

The VCD serves for gradual recording of executed verifications by the Supplier during the Contract realization. The records usually consist of date (time) when the verification was executed, by whom, the result (OK/NOK) and usually also reference to the related document as evidence of the result of verification.

7.1. Verification Control Document (VCD)

The CA requires that the Supplier will use the VCD document provided by the CA. The Supplier can extend and adapt the VCD document for better reflection to the real condition and fulfilment of the basic purpose of the VCD – to document and demonstrate the verification of fulfilment of CA requirements.

REQ-034387/A **R7-01**

The Supplier shall gradually execute the verification as required within this RSD as well as within the VCD draft provided by CA and record the results in to the VCD.

NOTE: Phases of delivery are called Deliverables in the Purchase contract.

Verification method: R – Review

7.2. Recommended verification methods

The verification process shall be accomplished by the Supplier through one or more of the following verification methods recommended by the CA:

1. Test – real verification that the subject of delivery fulfils required parameters usually carried out under controlled conditions, as close as possible to real operation. The Test protocols with test results or the complete Test report usually serve as the documented evidence. (Test - T) e.g.:
 - a. Test at the Supplier's site (Factory Acceptance Test – FAT);
 - b. Test at the CA's site (Site Acceptance Test – SAT);
 - c. Functional Demonstration at the Supplier or at the CA but always with CA attendance (Functional Demonstration – FD);
 - d. Measuring – specific type of Test - physical verification that the real measured value complies with the required value in the same units and standardized measuring conditions. The measurement protocol or report can serve as the documented evidence. The CA can also ask for the calibration protocol of used gauge or similar documentation. (Measuring – M).
2. Review – verification that the Documentation meets the requirements or the Documentation demonstrates the requirements fulfilment (Review – R).
3. Inspection – visual check or evaluation physical characteristics of the subject whether meet the requirements (Inspection – I).
4. Analysis - performing of theoretical or empirical evaluations of meeting the requirements by using defined methods (Analysis - A).

7.3. Qualification of Design

This chapter describes summary of what has to be provided by the Supplier in terms of documentation (detailed engineering documentation including technical documentation and design supporting documentation) before starting the manufacturing.

The output of this phase is **Final set of detailed engineering documentation, approved by the CA.**

REQ-034388/A **R7-02**
 Before completion of the Qualification of Design phase the Supplier shall provide following information that shall be agreed by the CA:

- structure and content of the Test protocols, Analysis reports, Review reports etc. (if applicable);
- structure and content of the VCD if it was modified by the Supplier.

NOTE: Phases of delivery are called Deliverables in the Purchase contract.

Verification method: R - Review

REQ-034389/A **R7-03**
 Before completion of the Qualification of Design phase the Supplier and the CA shall agree on:

- final detailed 3D model and detailed engineering drawings provided by the Supplier;
- detailed procedures related to the testing, cleaning and packaging during Manufacturing phase;
- common nonconformity control system (see REQ-034386/A).

NOTE: Phases of delivery are called Deliverables in the Purchase contract.

Verification method: R - Review.

7.4. Manufacturing and delivery

The goal is to demonstrate that all the manufactured and delivered parts of the contract meet all requirements specified herein.

The output of this phase is **All parts of the contract Verified and Delivered.**

REQ-034390/A **R7-04**
 The results of the Manufacturing phase of verification shall be recorded by the Supplier (including review of documentation/reports and inspection of all the manufactured and delivered parts) in the VCD (see section 7.1).

NOTE: Phases of delivery are called Deliverables in the Purchase contract.

Verification method: R - Review

REQ-034391/A **R7-05**
 The final issue of the VCD shall be submitted to the CA after the approval of the last report before delivery.

Verification method: I - Inspection

7.5. Acceptance

Acceptance will be carried out by the CA upon completion of each Phase of delivery (contractual Deliverable). In case of successful acceptance phase the CA will provide to the Supplier signed **Acceptance protocol** for each Phase of delivery. In case of unsuccessful acceptance stage the CA will provide to the Supplier **Nonconformity Report (NCR)** and process in accordance with REQ-034386/A shall be applied.

The final acceptance will be executed by the CA by verifying all criteria.

The Acceptance phase shall demonstrate the following:

- The final product(s) has (have) been successfully verified and this process has been documented in an appropriate way;
- All detected nonconformities have been solved in accordance with REQ-034386/A;
- The final product(s) is (are) free of fabrication errors, is (are) not damaged during transport and is (are) ready for the intended operational use.

REQ-034392/A **R7-06**

The Acceptance phase shall demonstrate the following:

- All finished parts of the contract have been successfully verified by the Supplier and the results of this process has been documented in VCD (The completed VCD is submitted);
- All previous Phases of delivery were accepted by CA and confirmed by the related Acceptance protocol (All the Acceptance protocols are submitted);
- All detected nonconformities have been solved in accordance with REQ-034386/A;

Verification method: Final CA verification

8. ANNEX: Drawings

8.1. RD-01 Drawing package L2 Laser Beam Distribution Vacuum Infrastructure

Electronic format of the drawing package, compressed into *.rar archive



EUROPEAN UNION
European Structural and Investing Funds
Operational Programme Research,
Development and Education



MINISTRY OF EDUCATION,
YOUTH AND SPORTS

ANNEX 3

VERIFICATION CONTROL DOCUMENT

ANNEX NO. 3
VERIFICATION CONTROL DOCUMENT
L2 Laser Beam Distribution Vacuum Infrastructure TP 22_011

Confidentiality:	<i>BL - Restricted for internal use</i>	TC ID/Revision:	00332369/A
WBS code:	4.2 – Beam Transport	PBS code:	<i>SE.BDS.BT.L2BT.S1, SE.BDS.BT.L2BT.S5</i>
Doc Status:	<i>DocReleased</i>	Doc Type:	<i>Specification (SP)</i>
Project Branch:	<i>Engineering & Scientific documents (E&S)</i>		

Table of Content

- 1. Quality Requirements for Supplier 2
 - 1.1. General Quality Requirements 2
 - 1.2. Nonconformity Control System 2
 - 1.3. Documentation and data control 3
- 2. Verification Requirements for Supplier 4
 - 2.1. General requirements 4
 - 2.2. Verification Documentation 4
 - 2.3. Verification Planning..... 5
 - 2.4. Verification execution..... 5
 - 2.5. Verification Control Document (VCD)..... 6
 - 2.6. Verification close out..... 7
- 3. Quality & Verification Plan 8
 - 3.1 Abbreviations 8
 - 3.2 List of compulsory Quality and Verification activities 9

ANNEX NO. 3
VERIFICATION CONTROL DOCUMENT

L2 Laser Beam Distribution Vacuum Infrastructure TP 22_011

TC ID/Revision: 00332369/A

Confidentiality: BL - Restricted for internal use

1. Quality Requirements for Supplier

1.1. General Quality Requirements

N°	TC N°		Requirement	Verification by
QR1-01	REQ-022310	A	The Supplier shall identify a Quality Manager for the project, responsible for implementing and performing management and other Quality disciplines and functions.	R - review
QR1-02	REQ-022311	A	If the Supplier delegates the quality assurance tasks to other organization it shall be done in a documented and controlled way monitored by the Supplier.	Not To Be Tracked within VCD
QR1-03	REQ-022312	A	The Supplier shall prepare, maintain and implement a Quality Plan for the product development and manufacturing to ensure that the product quality is in compliance with intended use and in conformity with requirements. <i>NOTE: The Client reserves the right to provide basic requirements for the Quality Plan.</i>	R - review
QR1-04	REQ-022313	A	The Quality Plan shall be submitted according to provisions of Annex 1.	R - review

1.2. Nonconformity Control System

N°	TC N°		Requirement	Verification by
QR1-05	REQ-022314	A	The Supplier shall establish and maintain a nonconformity control system compatible with ČSN EN ISO 9001 (equivalent to EN ISO 9001).	Not To Be Tracked within VCD

ANNEX NO. 3
VERIFICATION CONTROL DOCUMENT

L2 Laser Beam Distribution Vacuum Infrastructure TP 22_011

TC ID/Revision: 00332369/A

Confidentiality: BL - Restricted for internal use

1.3. Documentation and data control

N°	TC N°		Requirement	Verification by
QR1-06	REQ-022315	A	The Supplier shall supply the following relevant manufacturing documents: <ul style="list-style-type: none"> • Full technical documentation (including manufacturing drawings) • Breakdown list as built • Handling, installation and maintenance manuals • All approved "requests for deviation/waiver" (see REQ-022314; QR1-05). 	I – inspection
QR1-07	REQ-022316	A	All documentation shall be supplied in both hardcopy and PDF/A.	I – inspection
QR1-08	REQ-022317	A	The Supplier shall provide the following types of technical documentation: <ul style="list-style-type: none"> • Final 3D model (if available) • Final 2D drawings. 	R - review
QR1-09	REQ-022318	A	The Supplier shall use the following data formats: <ul style="list-style-type: none"> • *.JPG, *.PNG, *.PDF/A, *.HTML • CAD 2D: *.dwg • CAD 3D: *.stp; *.ste; *.step, *.x_t; *.x_b, or other 3D CAD formats agreed with the Client • Text processors *.doc, *.docx, OpenDocument Format • Spreadsheet processors *.xls, *.xlsx, OpenDocument Format • Presentations *.ppt, *.pptx; OpenDocument Format. 	Not To Be Tracked within VCD

ANNEX NO. 3
VERIFICATION CONTROL DOCUMENT

L2 Laser Beam Distribution Vacuum Infrastructure TP 22_011

TC ID/Revision: 00332369/A

Confidentiality: BL - Restricted for internal use

2. Verification Requirements for Supplier

2.1. General requirements

N°	TC N°		Requirement	Verification by
QR2-01	REQ-022319	A	The verification process shall be managed by the Supplier and shall proceed according to the Verification Plan (VP), see provisions of Annex 1. The verification process shall include the following activities: 1. Verification planning (see section 2.3 below) 2. Verification execution and reporting (see section 2.4 below) 3. Verification control and close-out (see sections 2.5 and 2.6 below).	Not To Be Tracked within VCD
QR2-02	REQ-022320	A	The Supplier shall assign clear responsibility for the implementation of the verification process including the activities defined in QR2-01 (REQ-022319).	R - review

2.2. Verification Documentation

N°	TC N°		Requirement	Verification by
QR2-03	REQ-022335	A	The Supplier shall establish and maintain the system of verification process documentation.	Not To Be Tracked within VCD
QR2-04	REQ-022336	A	Verification documentation shall consist of following basic types of documents: <ul style="list-style-type: none"> • VP, Verification Plan (see section 2.3) • Verification Reports including: CDR Report, Tests, Inspection and Analyses reports (see section 2.4) • VCD, Verification Control Document (see section 2.5). 	Not To Be Tracked within VCD
QR2-05	REQ-022337	A	The verification report shall be submitted to the Client for the review as agreed with the Client after corresponding verification activity completion, within the time frame agreed with the Client. <i>NOTE: Verification activity can be design review and analysis during the development, test and inspection of all System Components.</i>	R - review

ANNEX NO. 3
VERIFICATION CONTROL DOCUMENT

L2 Laser Beam Distribution Vacuum Infrastructure TP 22_011

TC ID/Revision: 00332369/A

Confidentiality: BL - Restricted for internal use

2.3. Verification Planning

N°	TC N°		Requirement	Verification by
QR2-06	REQ-022321	A	The Supplier shall define the verification approach in a Verification Plan (VP) for approval by the Client prior to implementation.	Not To Be Tracked within VCD
QR2-07	REQ-022322	A	The Verification Plan (VP) shall describe HOW and WHEN each of the technical requirements will be verified: <i>NOTE 1: The Client reserves the right to provide binding guidelines for establishing the VP, within 15 working days from the Commencement Day of the contract.</i> <i>NOTE 2: Guidelines for VP preparation can be provided by the Client.</i>	R – review

2.4. Verification execution

N°	TC N°		Requirement	Verification by
QR2-08	REQ-022323	A	The verification execution process shall consist of following stages according to the phasing of the contract execution: <ul style="list-style-type: none"> • Critical design review (CDR); • Verification of all components of the System Components (testing and inspection at Supplier’s site); • Acceptance by the Client at customer site. <i>NOTE 1: The CDR is intended to verify that the design meets corresponding requirements (could be accepted) and/or identify required corrective actions needed to accept the design and start manufacturing phase of the contract.</i> <i>NOTE 2: Verification of all System Components is executed at the end of each corresponding manufacturing phase by inspection and tests. The purpose of this verification is checking the product readiness for shipment to the Client.</i> <i>NOTE 3: In the acceptance stage the verification shall demonstrate that the product meets the specifications (see Annex 2 of the Contract) and that it is free of fabrication defects and is ready for the intended operational use.</i>	Not To Be Tracked within VCD
QR2-09	REQ-022324	A	Acceptance shall be carried out on final hardware and software. <i>NOTE 1: Output of this verification stage is Verified System.</i> <i>NOTE 2: The results of acceptance stage shall be recorded by the Client within VCD (see section 2.6).</i>	Not To Be Tracked within VCD

ANNEX NO. 3
VERIFICATION CONTROL DOCUMENT

L2 Laser Beam Distribution Vacuum Infrastructure TP 22_011

TC ID/Revision: 00332369/A

Confidentiality: BL - Restricted for internal use

QR2-10	REQ-022325	A	<p>Verification shall be accomplished by the Supplier through one or several of the following methods:</p> <ol style="list-style-type: none"> 1. Review of design; Verification by Review (R) shall consist of using official project documentation (e.g. design and technical documentation, numerical analysis reports, engineering drawings, manuals and operation documentation) that unambiguously shows that the requirement is met. 2. Inspection; Verification by Inspection (I) shall consist of visual examination of the manufactured and/or assembled product. 3. Test (including functional demonstration); Verification by Test (T) shall consist of quantitatively measuring performance of the product and of its functions in a defined operating regime. 4. Analysis; Verification by Analysis (A) shall consist of performing numerical or empirical performance evaluation of the product using a technique defined in the VP (see QR2-06; REQ-022321). 	Not To Be Tracked within VCD
QR2-11	REQ-022326	A	<p>The results of a review of design shall be documented in the Critical Design Review Report (CDRR) and tracked in the VCD. <i>NOTE: The Client can provide to the Supplier the template of CDRR.</i></p>	R – review
QR2-12	REQ-022330	A	<p>The results of a review of analysis shall be documented in the appropriate Analysis Report (AR) and tracked in the VCD.</p>	R – review
QR2-13	REQ-022327	A	<p>The results of the inspection shall be documented in the appropriate Inspection Report (IR) and tracked in the VCD.</p>	R – review
QR2-14	REQ-022328	A	<p>The results of the test shall be documented in the appropriate Test Report (TR) and tracked in the VCD.</p>	R – review
QR2-15	REQ-022329	A	<p>The parts of the VCD related to the Design of all System Components shall be accepted by the Client before manufacturing of the System starts.</p>	Not To Be Tracked within VCD

2.5. Verification Control Document (VCD)

The Verification Control Document (VCD) lists the requirements to be verified with the selected methods at the defined levels. The VCD is a living document and provides traceability during contract phases (design, manufacturing, testing and deployment) how each requirement is planned to be verified and is actually verified.

The VCD represents a formal tool of communication between the Supplier and the Client (formal record, reporting tool).

N°	TC N°		Requirement	Verification by
QR2-16	REQ-022338	A	<p>The Supplier shall provide the first version of the Verification Control Document (VCD) as a part of the D1 Deliverable. <i>NOTE: Binding guidelines for VCD preparation will be provided by the Client within 15 working days from the Commencement Day of the contract.</i></p>	R - review

ANNEX NO. 3
VERIFICATION CONTROL DOCUMENT

L2 Laser Beam Distribution Vacuum Infrastructure TP 22_011

TC ID/Revision: 00332369/A

Confidentiality: BL - Restricted for internal use

2.6. Verification close out

Acceptance will be carried out on the System Components after their delivery.

In case of successful acceptance phase the Client shall provide to the Supplier signed acceptance protocol. In case of unsuccessful acceptance phase the Client shall provide to the Supplier Nonconformity Report (NCR) and process in accordance with QR1-05 (see REQ-022314) shall be applied.

N°	TC N°	Requirement	Verification by
QR2-17	REQ-022421/A	A Upon delivery of the System Components in appropriate and undamaged packaging the Client shall provide to the Supplier with Handover/takeover protocol.	Not To Be Tracked within VCD
QR2-18	REQ-022332	A The verification process shall be considered complete for a given project phase (contractual Deliverables) when the Client approves all corresponding items in the VCD by confirming that: <ol style="list-style-type: none"> 1. All specified requirements for a given project phase (contractual Deliverable) have successfully been verified by the Supplier and results of this verification process has been approved by the Client; 2. All detected nonconformities have been solved in accordance with QR1-05 (REQ-022314); 3. Documented evidence is recorded in the VCD. <p><i>NOTE: In the acceptance phase, the verification of the delivered System Components and required documentation will be carried out and tracked by the Client in the final version of the VCD within 4 weeks after the issuing of the latest Handover/takeover protocol (D9).</i></p>	Not To Be Tracked within VCD

ANNEX NO. 3
VERIFICATION CONTROL DOCUMENT

L2 Laser Beam Distribution Vacuum Infrastructure TP 22_011

TC ID/Revision: 00332369/A

Confidentiality: BL - Restricted for internal use

3. Quality & Verification Plan

The table in Section 3.2 below summarizes the compulsory Quality and Verification activities of design, manufacturing, testing and delivery. These activities must be included in the detailed Quality and Verification Plan developed by the Supplier.

3.1 Abbreviations

Abbreviation	Meaning	Note
I	Inspection	As verification methods; Further details see QR2-10 (REQ-022325)
RoD	Review of Design	
T	Test	
A	Analysis	
FD	Functional Demonstration	
R	Review	Relevant official project documents for a given activity shall be reviewed, and a review report issued, by a responsible person at the Client.
H	Hold point	Progress shall not be made to the next sequenced activity until the Requirements of the Hold Point Activity have been met
W	Witness point	The activity shall be witnessed in person with appropriate advance notice having been given.
QR	Quality Report	All items from the Quality Plan, see QR1-03 (REQ-022312), corresponding to the given activity, must be documented
AR	Analysis Report	Documented results of corresponding verification activities shall be submitted to the Client (see section 2.4)
IR	Inspection Report	
TR	Test Report	
n/a	not applicable	
CDR	Critical Design Review	Details see in QR2-08 (REQ-022323)
CDRR	CDR Report	Details see in QR2-11 (REQ-022326)
VP	Verification Plan	Details see in section 2.3
VCD	Verification Control Document	Details see QR2-16 (REQ-022338)
ELI-BL	ELI-Beamlines	-

ANNEX NO. 3
VERIFICATION CONTROL DOCUMENT

L2 Laser Beam Distribution Vacuum Infrastructure TP 22_011

3.2 List of compulsory Quality and Verification activities

Seq. No	Activity	Input Requirement / Specifications	Place	Quality process		Verification process		Contractor		ELI-BL	
				Input	Output	Input	Output	Quality	Verification	Quality	Verification
1	Detailed project schedule, detailed engineering design (Deliverables D1 and D2)										
1.1	Contract kick-off and planning meeting	Kick off meeting agenda	ELI-BL or Contractor	n/a	Minutes	n/a	n/a	R	n/a	R	n/a
1.2	Design of specific components, drawings and schemes	Detailed concept design and 3D models, detailed engineering drawings for components and subsystems	ELI-BL or Contractor	Engineering drawings and schemes	Critical Design Review Report (CDRR), QR (Quality Report)	Engineering drawings and schemes	CDRR VP VCD (Annex 3 of the Contract)	n/a	RoD	H	RoD
1.3	Design of routing of primary backing vacuum, utilities, and electrical cables	3D concept design, detailed technical specifications (Annex 2 of the contract)	ELI-BL or Contractor	Engineering drawings and schemes	Critical Design Review Report (CDRR)	Engineering drawings and schemes	CDRR	n/a	RoD	H	RoD
1.4	Review of the contractor qualifications and procedures before launching fabrication	Contractor qualifications and procedures	Contractor	Contractor qualifications and procedures	Inspection report	n/a	n/a	n/a	n/a	W	I
1.5	Failure Mode and Effect Analysis (FMEA)	Detailed technical specifications (Annex 2 of the contract)	ELI-BL or Contractor	Detailed technical specifications	Analysis Report (AR)	n/a	n/a	AR/H	A	R	RoD

ANNEX NO. 3
VERIFICATION CONTROL DOCUMENT

L2 Laser Beam Distribution Vacuum Infrastructure TP 22_011

Seq. No	Activity	Input Requirement / Specifications	Place	Quality process		Verification process		Contractor		ELI-BL	
				Input	Output	Input	Output	Quality	Verification	Quality	Verification
2	Manufacture, factory testing, and delivery to ELI-Beamlines (Deliverables D3 and D4)										
2.1	Welding coordination tasks and responsibilities	ČSN EN ISO 14731 * (equivalent to EN ISO 14731 *)	Contractor	ČSN EN ISO 14731 * (equivalent to EN ISO 14731 *)	Certificates	n/a	n/a	H	I	R	I
2.2	Welding personnel qualifications	ČSN EN ISO 9606 *, ČSN EN ISO 14732 * or relevant (equivalents to EN ISO 9606*, EN ISO 14732 *)	Contractor	ČSN EN ISO 9606 *, ČSN EN ISO 14732 * or relevant (equivalents to EN ISO 9606*, EN ISO 14732 *)	Certificates	n/a	n/a	H	I	R	I
2.3	Inspection of the new material and components, traceability	Raw material certificates and contractor traceability procedures	Contractor	Raw material certificates and contractor traceability procedures	Certificates and procedures	n/a	n/a	H	I	R	I
2.4	Welding inspection	Production drawings, welding procedures, welding sequence plan	Contractor	Production drawings, welding procedures, welding sequence plan	Inspection report	n/a	n/a	H	n/a	W	n/a
2.5	NDT inspection of the vacuum chambers	NDT procedures	Contractor	NDT procedures	Inspection report	NDT specifications	Test / Inspection report	H	T, I	R	R, I
2.5a	Visual inspection 100% EN ISO 17637 *	ČSN EN ISO 5817 * (equivalent to EN ISO 5817 *), evaluation group B	Contractor	Criteria according to ČSN EN ISO 5817 * (equivalent to EN ISO 5817 *), evaluation group B, product to be verified	Inspection report	Criteria according to ČSN EN ISO 5817 * (equivalent to EN ISO 5817 *), evaluation group B, product to be verified	Inspection report	H	I	W	R, I
2.5b	Surface crack test /PT/ of all load bearing parts and vacuum welds EN ISO 17637 *	ČSN EN ISO 23277 * (equivalent to EN ISO 23277 *), evaluation group 1	Contractor	Criteria according to ČSN EN ISO 23277 * (equivalent to EN ISO 23277 *), evaluation group 1, product to be verified	Inspection report	Test specifications	Test / Inspection report	H	T, I	W	R, I

* Regarding the referred standards or standardized/ standardizing technical documents the Client allows also another equivalent solution to be offered.

ANNEX NO. 3
VERIFICATION CONTROL DOCUMENT

L2 Laser Beam Distribution Vacuum Infrastructure TP 22_011

TC ID/Revision: 00332369/A

Confidentiality: BL - Restricted for internal use

Seq. No	Activity	Input Requirement / Specifications	Place	Quality process		Verification process		Contractor		ELI-BL	
				Input	Output	Input	Output	Quality	Verification	Quality	Verification
2.6	Inspection of the finished chamber structure including visual inspection, surface and dimensional control	Production drawings Detailed Technical Specifications (Annex 2 of the Contract)	Contractor	Production drawings, Detailed Technical Specifications	Inspection control report	Production drawings, Detailed Technical Specifications	Inspection and dimensional control report	H	T, I	W	R, I
2.7	Measurement of deformations of the vacuum chambers walls upon pump down	Production drawings Detailed Technical Specifications (Annex 2 of the Contract)	Contractor	Production drawings, Detailed Technical Specifications	Quality report	Test specifications	Test report	H	T, I	W	R, I
2.8	Inspection of the cleaned vacuum chambers, vacuum leak and vacuum cleanliness tests	Manufacturing requirements including the cleaning procedure Vacuum test requirements	Contractor	Manufacturing requirements including cleaning procedure Vacuum test requirements	Quality report	Manufacturing requirements including cleaning procedure Vacuum test requirements	Test report	H	T, I	W	R, I
2.9	Acceptance of each of the vacuum chambers vacuum tested	Detailed technical specifications (Annex 2 of the contract)	Contractor	Detailed technical specs (Annex 2 of the contract)	Inspection and Test report	Detailed technical specs (Annex 2 of the contract)	Test report	H	T, I	W	R, I
2.10	Packaging for transport	Packaging for transport	Contractor	Contractor	Part list Shipping specifications	Shipping list	n/a	n/a	H	I	W
2.11	Shipping and reception at ELI-Beamlines	Shipping and reception specifications	ELI-BL	Shipping and reception specifications	Reception report	n/a	n/a	W	I	H	I
2.12	Unpacking and inspection	Unpacking and storage specifications Manual / specifications for installation	ELI-BL	Unpacking and storage specifications Manual /specifications for installation	Reception report	n/a	n/a	n/a	n/a	H	I

Note: Regarding the referred standards or standardized/ standardizing technical documents throughout this document, the Client allows also another equivalent solution to be offered.



ANNEX 4

SUPPLIER'S BID

A) Precision of manufacture of large flanges ISO400 above Tolerance Grade "A" specifications

The large flanges ISO400 shall be manufactured with the following precision: +/- 0,3 mm

B) Warranty periods

The Supplier provides a warranty of quality on the complete Object of Purchase for the period of 36 months.

C) Qualification prerequisites

The Supplier shall carry out assembly and testing works hereunder in the cleanroom space described within the Bid as follows:

Brief description of the cleanroom space in terms of dimensions of the area and cleanliness class specification:

STREICHER has around 1,700 m³ of clean room of ISO Class 6 according to EN ISO 14644-1 with a vast 6.6 m ceiling height for final cleaning, assembling and testing of large vacuum units. The footprint of ISO Class 6 clean room is 14,6 m x 9 m. These dimensions allow to fit up assembly groups of up to 10 tons by using a gantry crane. The clean room comprises two separate rooms, grey room for pre-cleaning and a gowning area.

The Supplier shall use the following persons it identified within its Bid for performing this Contract while carrying out all the relevant activities hereunder:

<vypuštěno>	Senior optomechanical designer
<vypuštěno>	Junior optomechanical designer
<vypuštěno>	Junior optomechanical designer
<vypuštěno>	Welding coordination supervisor
<vypuštěno>	Qualified welder
<vypuštěno>	Qualified welder

The Supplier is allowed to use another cleanroom space or another persons only if it proves that such spaces or persons meet the requirements for the cleanroom space or team members stated in the procurement documentation issued for the purposes of the Public Contract award.