

**CONTRACT  
Nr.: 0424001706**

## **Purchase of Pushback Conventional Tractor**

**between**

### **Czech Airlines Handling, a.s.**

Registered office at: Aviatická 1017/2, 160 08 Prague 6, Czech Republic  
ID Number (IC): 25674285  
VAT Reg. Number: CZ699003361

Company established under the laws of the Czech Republic registered in Commercial Register maintained by the Municipal Court in Prague, Section B, and File No.17139, represented by Mr. Jiří Jarkovský, Chairman of the Board of Directors and Mr. Michal Soukup, Vice- Chairman of the Board of Directors

Hereinafter referred to as "**Buyer**"

**-and-**

### **SCHOPF Maschinenbau GmbH**

Registered office at: Parkstrasse 19-21, 73760 Ostfildern, Germany  
VAT Reg. Number: DE 145 353 101  
represented by: Thomas Kramer / Ursula Sarawinsky

Hereinafter referred to as "**Seller**"

(Collectively, hereinafter referred as "**Contractual parties**" and each separately hereinafter the "**Party**")

(hereinafter referred to as "Contract")

#### **Purpose of the Contract**

Purpose of this Contract is to set forth the the terms and conditions under which the Seller sells to the Buyer **one piece of new pushback conventional tractor**, suitable with technical requirements specified in the Attachment 1 of this Contract in time, complete, fully functional and accomplishing all agreed and all usual demands according to Attachment 1 (hereinafter referred as "Product").

## 1. Subject of the Contract

1.1 In accordance with the terms and conditions of this Contract, the Seller shall sell and the Buyer shall purchase:

- 1 x pushback conventional tractor (SCHOPF Maschinenbau GmbH F70) in accordance with the technical specification stipulated in Attachment 1 of this Contract (hereinafter referred to as "Product")

## 2. Prices

2.1 Price of the Product is set in EUR as specified in technical specification in Attachment 1 of this Contract and ("hereinafter referred as **"Price"** or **"Value of Product"**"), delivery terms are according to Incoterms 2010 DAP – certain place of delivery is specified in Article 4.2 of this Contract. The price is quoted without VAT and is final, no duties and charges will be additionally levied.

**Delivery of 1 new pushback conventional tractor with ballast up to 11 t -  
Price/Value of Product (SCHOPF Maschinenbau GmbH F70):** [REDACTED]

2.2 Price includes all items in accordance with Attachment 1 accompanied by the certificate of conformity, packaging, transportation, completing and commissioning, training of Buyer's specialists, manual in Czech language.

2.3 Costs for commissioning and acceptance test procedure for up to two (2) Buyer's staff members provided by the Seller in his factory are included in total price. Flights and hotel costs are to the Buyer's account. All other charges as well transport from Stuttgart airport to Seller's factory and back are at Seller's charge. The training for Buyer's operation staff members will be organised in Prague Vaclav Havel Airport after the delivery Product to Prague the Price of this training (all other charges include flights and hotel costs the working hours, travel costs, daily allowances and overnight expenses) is already included in the Price of the Product. The price of the Product and services is definitive and shall not be subject to any price escalation.

2.4 The final invoice shall be paid within [REDACTED] to the Buyer, after delivery of the Product to the place specified by Buyer. However the following documents shall be handed over before the delivery of the final invoice to the Buyer:

- commercial invoice that complies with local tax law in effect
- packing list (delivery order);
- original of transport document (CMR etc.) ;
- factory acceptance certificate signed by the representatives of the Seller and the Buyer in the Seller's factory;
- certificate of insurance for transport to Prague covering total Value of Product;
- Documentation:  
Two Operating and maintenance manuals in the Czech language, spare-parts catalogues, electric and hydraulic schematics in the English language.

- Data sheet;
- Operating and maintenance instruction
- Hydraulic and electric schematics;
- Illustrate spare parts catalogue;
- Sub - supplier information; (Limited to manufactures of Engine, Transmission an Axles)

- Certificate of conformity according all IATA and CE regulations especially IATA AHM 955, AHM 910, AHM 913, AHM 915, AHM 914, AHM 916 and EN 12312-7

### 3. Invoicing and payment conditions

- 3.1 The invoice shall contain requisites determined by relevant legal regulations (the local VAT law that complies with the EU VAT law), valid and effective on the time of invoice issue. All tax documents shall have stated the number of the order, the name of its processor, the number of the item (if stated on the order), the places where this item was supplied, the specification of the item, the batch number of the item, the amount of delivered goods, the unit price and the photocopy of the delivery note. The invoice shall also contain number of this Contract. Unless the sent invoice contains requisites determined by the legal regulations or unless stated abovementioned information, then the Buyer is entitled to return the invoice for the addition. In this case the new 30-day maturity begins from the time the supplemented or corrected invoice is provable received by the Buyer and the Seller shall not claim any sanctions or the delay payments to the Buyer until correct invoice with all above stated requisites is delivered to the Buyer.
- 3.2 All taxes, customs duties (if any) levied on the territory of the Seller's country shall be borne by the Seller. All taxes, customs duties (if any) levied in the country of the Buyer shall be borne by the Buyer. Each company shall be responsible for its own corporate taxes imposed by the state of tax residence of any party or by international tax law no matter if such taxes are administered by the other contracting party.
- 3.3 Ownership right and damage risk to the Product shall pass to the Buyer after full payment of the Price by the Buyer.
- 3.4 Invoice is paid, when the respective amount is charged-off from the Buyer's bank account. Invoice is paid when the respective amount is received on the Seller's bank account.
- 3.5 Seller's bank details

Kreissparkasse Esslingen – Nürtingen  
IBAN: DE69 61150020 0100043723  
SWIFT/BIC: ESSLDE66

Landesbank Baden-Württemberg  
IBAN: DE33 60050101 0008412951  
SWIFT/BIC: SOLADEST

All invoices shall be sent to the Buyer as following:

to post address:

[REDACTED]  
[REDACTED]  
[REDACTED]  
[REDACTED]  
[REDACTED]

or via email in PDF form to:

[REDACTED]

#### **4. Delivery Schedule and Conditions**

4.1 The delivery of all Products must be done at the place of delivery **within [REDACTED] from the date this Contract was signed.**

4.2 The delivery term is DAP – Incoterms 2010. Products shall be delivered to:

[REDACTED]  
[REDACTED]  
[REDACTED]  
[REDACTED]  
[REDACTED]

Contact:

[REDACTED]  
[REDACTED]  
[REDACTED]  
[REDACTED]

4.3 The Product is delivered by handing over to the Buyer at the place of delivery, whereas the Product shall be brand new, not burdened by any rights of third persons including any pledge, free of any defects, meeting all requirements set forth by this Contract and all relevant legal acts and regulations, hygienic, health and other relevant norms concerning such products, completed and ready to use.

4.4 All expenses relating to the shipment and the insurance shall be paid by the Seller, without recharge to the Buyer.

#### **5. Warranty**

5.1 Seller warrants that the Product will be fully functional, free from any defects at least for twenty four (24) months from the date, that the Product have been delivered to the Buyer, provided that it is installed, stored, handled, operated and maintained in accordance with the Maintenance manual issued by Seller and/or Producer together with normal aviation practices.

5.2 The Product delivered by the Seller shall be brand new.

5.3 In the event of any defects in the Product or if the Product is found to be faulty Seller is obliged to take all possible measures to remedy this defect at his own expense, and no later than 7 (seven) days from receipt of the notice of malfunction from the Buyer. The Parties have agreed that this Product will be either repaired or replaced with a new, without any additional costs charged to the Buyer. Solving the defect is mutual assessed with regard to the aspect of time, effort and defects of costs. Seller expressly agrees, that if repairs are needed and the correction could be done by the Buyer in his workshop, then Seller sends no later than 3 (three) days from receipt of the request of the Buyer spare parts required to remove the fault immediately under the DAP - certain place specified in Artic 4.2 of this Contract. If this is necessary, Seller sends his technique for the Product repairation no later than 3 (three) days from receipt of the request of the Buyer. Any expenses incurred for such repair

(labor and materials required for the repairation of the Product and/or the transport costs from Prague to the Seller's factory of items that are replaced or repaired under this warranty) and technique visit at Buyer`s workshop (the working hours, travel costs, daily allowances and overnight expenses) will be born by the Seller. Such procedure specified in this Article does not effect warranty rights.

- 5.4 The Seller anticipates the supply of spare parts and services for the delivered Products will be available for a period of minimum fifteen (15) years after the end of the warranty period. Seller undertakes to conclude an agreement with the Buyer for this activity to establish closer cooperation conditions of Parties.
- 5.5 In the event of a defect of the Product delivered by Seller, Seller may in its sole discretion decide to correct the defect of the Product or to deliver equivalent Product. Seller`s liability for damages under Article 9 of this Contract shall remain unaffected.
- 5.6 In case any defect keeps the delivered goods out of operation for more than five (5) days to be counted from the date on which the Buyer informs the Seller in writing, a period equivalent to the duration of the defect will be added to the warranty period. The Seller in such a case undertakes at his own expense all measures to eliminate the mentioned defect(s) not later than within three (3) days from the time in which he receives the notice about the defect.

## **6. Non- Excusable Delay**

- 6.1 If the event that Seller does not deliver the Product within one (1) week after the delivery date specified in Art.4.1, the Seller shall pay from the first day of delay a penalty calculated from the Value of Product (delayed - undelivered) as follows:

0,05 per cent for each day during the first 30 days of delay,  
0,3 per cent for each day from the 31<sup>st</sup> day and following days of such delay.

In case that Product will be not delivered till thirty (30) days after agreed delivery date, the Buyer may withdraw this Contract immediately.

- 6.2 In the event that Seller fails to remedy any defect within the time limit specified in Art. 5.3, the Seller shall pay from the first day of delay, after a period of 7 days, penalty calculated from the Value of Product as follows:

0,5 per cent for each week in case that Product is completely out of order or such defect prevents the use of the Product as a whole up to a max. amount of Euro 3.000,--

In the event that Seller does not deliver the missing and/or replace the damage parts of the Products after the delivery date specified in Art. 7.6, the Seller shall pay from the first day after that period of delay a penalty calculated from the Value of Product as follows:

0,5 per cent for each week of delay up to a max. amount of Euro 3.000,--

In any case penalty is limited to the warranty period

## **7. Commissioning and acceptance of the Product**

- 7.1 Commissioning and acceptance test of the Product for up to two (2) Buyer's staff members will be organised in Seller's factory for two (2) days, 14 weeks after date of signature this Contract, but at least the 1 (one) prior delivery of Product. Overnight expenses costs and travel costs from Prague to Stuttgart Airport and back of Buyer's staff during this commissioning and acceptance test of the Product shall be borne by the Buyer. All other charges such as transport costs from Stuttgart Airport to Seller's factory and back are at Seller's charge. The Acceptance Certificate shall be issued and duly signed by representatives of both Contractual parties after the successful training in the Seller's factory. Should the unit not comply with the Contract conditions at the time of the first acceptance and the second acceptance will become necessary, the Seller will pay cost for travelling, board and lodging (if necessary) for one Buyer's staff member for the second acceptance test. The Buyer has the right to authorise the Seller to complete the acceptance test in the absence of the Buyer according to the agreed acceptance procedure.
- 7.2 Not applicable.
- 7.3 The acceptance test shall demonstrate the complexity of the Product and their compliance with the technical specification and performance as described in this Contract and its Attachment 1.
- 7.4 The acceptance of the Product delivered under this Contract (quantity and visual damage) shall be performed by the Buyer by visual inspection within five (5) business days after receipt of Product in the place of delivery pursuant to art. 4.2 of this Contract.
- 7.5 Should an nonconformity in comparison with Purchase Order, Contract, invoice and shipping documents and actual content and stage of the shipment be observed (as for the complete or partial damage, impairment or breakage of the Product on account of improper or unsound packing, shortage in quantity, visual damage of the packing, visual damage of goods) the Buyer shall draw up the Report and make respective claims to the Seller depending on the causes of damage within fifteen (15) days after receipt of the Product.
- 7.6 The Seller shall within thirty (30) business days after receipt the Report specified in Article 7.5 of this Contract deliver the missing or replace the damaged parts of the Products and commence the remedy of damage at his expense if Seller's responsibility.

## **8. Miscellaneous and Force Majeure**

- 8.1 Either Contractual party shall undertake not to disclose to third parties any terms and conditions of the present Contract, as well as any other information, materials and documents submitted to each other in accordance with the present Contract with the exceptions such release is required by the law or by state authorities of the Buyer's or Seller's country. Contractual Parties both agree, that Buyer is entitled to disclose this Contract and/or any Confidential Information obtained under and/or in connection with this Contract to Český Aeroholding, a.s., Corporate ID No.: 248 21 993, with its registered seat in Prague 6, Jana Kašpara 1069/1, Postal Code 160 08, Czech Republic (hereinafter "CAH") and to all entities (including their directors, officers and employees), in which as of the date of such disclosure CAH directly or indirectly owns a share.

- 8.2 Neither Party to this Contract will be able for any failure or delay in the performance of its obligations or the exercise of its rights hereunder or for any loss or damage resulting therefrom, if such performance or exercise is delayed in whole or in part by reason of a Force Majeure Event.
- 8.3 The Party affected by the Force Majeure Event shall promptly notify the other Party in writing of the circumstances constituting the Force Majeure Event, the date on which it began and the obligations which are thereby delayed or prevented (such obligations to be suspended until such Force Majeure Event and its consequences have ceased to exist). The Parties will meet in good faith to discuss how to best mitigate the Force Majeure Event in order to minimize its impact on the performance of the Parties' obligations under this Contract.

## **9. Liability and Indemnification**

- 9.1 Seller will be liable towards the Buyer for damage to or loss of property and for the injury to or death of any person caused by the negligence or the misconduct of its directors, officers, employees, agents or subcontractors in connection with or as a result of the Product rendered under this Contract.
- 9.2 Seller will indemnify and hold harmless Buyer, its directors, officers, employees, agents and Subcontractors and/or third Parties from and against all claims of third parties related to damage, loss, injury or death caused by the negligence or the misconduct of Seller, its directors, officers, employees, agents or subcontractors.
- 9.3 The liability and indemnification include all necessary costs, expenses and fees incident, indirect, incidental or consequential damages such as but not limited to loss of profit or loss of revenue.
- 9.4 Seller agrees that it shall without undue delay give written notice to the Buyer of any matter or event coming to its knowledge which may result in a Seller incurring liability hereunder. We agree up to the limit of our product liability insurance (copy of insurance certificate attached).

## **10. Law and Jurisdiction**

- 10.1 This Contract shall be governed by the laws and regulations of the Czech Republic. All disputes which arise under this Contract which the Contractual parties are not able to amicably resolve shall be resolved by a court of competent jurisdiction situated in the Czech Republic.
- 10.2 Disputes shall not be settled by arbitration courts, unless the Contractual Parties in particular case expressly agree otherwise in writing.

## **11. Entire Contract**

- 11.1 This Contract constitutes the entire contract between the Contractual parties hereto and supersedes all previous communications, purchase orders, representation agreements, either oral or written, heretofore made between the parties in respect of the subject matter hereof.
- 11.2 There is mutually agreed between Parties, that any modification or amendments to this Contract shall not be varied other than in writing signed by the duly authorized representative(s) of each Contractual party.

- 11.3 All alterations and amendments shall be considered as valid and binding only when confirmed by both Contractual parties. Only a purchasing representative of the Buyer and representative of the Seller with actual express authority shall be authorized to execute any modifications and amendments to this Contract.
- 11.4 Any notice or communication to be given hereunder this Contract shall be in written form, addressed to the respective Parties by e-mail and fax followed by certified mail as follows:

The Buyer`s address:	The Seller`s address:
[Redacted]	

	The Buyer`s contact person:	The Seller`s contact person:
[Redacted]		

- 11.5 This Contract shall be valid from the date of signature by both Contractual parties until all the obligations of both Contractual parties resulting from the Contract will be fulfilled.
- 11.6 In the event of any discrepancy between the wording of this Contract and the INCOTERMS 2010, the wording of this Contract shall prevail.
- 11.7 In case that either a clause of this Contract or a part of it should be or become invalid, the other conditions will remain unaffected. A valid clause with the same or a similar economical meaning shall mutually be agreed upon and put down in writing to replace the ineffective or missing one.
- 11.8 Seller may not assign any interest, benefit, right or obligation arising out of this Contract to any third party without having obtained prior written consent of the Buyer.
- 11.9 The Buyer's rights and remedies contained in this Contract are cumulative and not exclusive of rights or remedies provided by law.
- 11.10 A failure to exercise or delay in exercising a right or remedy provided by this Contract or by law does not constitute a waiver of the right or remedy or a waiver of other rights or remedies. No single or partial exercise of a right or remedy provided by this Contract or by law prevents further exercise of the right or remedy or the exercise of another right or remedy.
- 11.11 The Contractual parties have agreed that Seller is not entitled a mutual set-off of pecuniary obligations arising under this Contract.
- 11.12 The Contractual parties agree that the Seller's obligation to pay the contractual penalty does not exclude the Buyer's right to compensation in full.
- 11.13 The Seller acknowledges that the Buyer is a person covered by the Act No. 340/2015 Coll., on special conditions for the effectiveness of some Contracts, the disclosure of Contracts and about Registry of the Contracts (Law on Registry of Contracts).



11.14 The Contractual parties agree that Price (Value of Product) referred to in Article 2.1 of this Contract, payment deadline of the final invoice in Article 2.4 of this Contract and delivery time referred to in Article 4.1 of this Contract constitute business secrets within the meaning of Section 504 of the Civil Code, and undertake to ensure its confidentiality and protect it accordingly. For the avoidance of doubt, the Contractual parties claim that the other facts stated in this Contract and its annexes before the facts stated in the first sentence of this provision of the Contract are not considered a business secrets.

11.15 The Contractual parties have agreed that Seller is obliged to expiate any no-pecuniary damage.

11.14 Attachment 1 is an integral part of this Contract.

## 12. Signatures

In witness whereof, the Contractual parties hereto have set their hand and signature on the day hereunder mentioned.

*This Contract is made out of 3 (three) identical copies in English language, each being valid as original. Buyer shall keep 2 (two) copies and Seller shall keep 1 (one) copy of the Contract.*

Date: .....

**Czech Airlines Handling, a.s.**

Date: .....

**SCHOPF Maschinenbau GmbH**

.....  
By: Jiří Jarkovský

Title: Chairman of the Board of Directors

.....  
By: [REDACTED]

Title: [REDACTED]

.....  
By: Michal Soukup

Title: Vice-Chairman of the Board of Directors

.....  
By: [REDACTED]

Title: [REDACTED]

## Attachment 1 - Technical specification of Pushback Conventional Tractor

### 1 SCHOPF F70 Aircraft Towing Tractor

#### General features:

- ✓ 4 wheel drive and 4 wheel steering
- ✓ Sight tunnel to the rear
- ✓ Heavy steel frame made of steel plates
- ✓ Left hand drive steering
- ✓ Tyres, front + rear 235/75 R17,5

#### Engine:

- ✓ Deutz TCD 3,6 Diesel engine  
Water-cooled, turbo charged, 4 cylinders in-line  
69,5 kW (94,3 HP) at 2,300 rpm acc. To ISO 14396  
Integrated engine management system EMR  
Exhaust emission acc. to EU guidelines 2004/26/EC, Step IIIB / EPA IVi

#### Transmission:

- ✓ DANA T12000 full-power-shift transmission with integrated torque converter
- ✓ Fully automatic
- ✓ 4 gears forward, 3 gears reverse

#### Braking system:

- ✓ Fully hydraulic, 3 circuits safety brakes with accumulator back-up
- ✓ Service brakes: 2 circuits oil-immersed lamella disc service brake
- ✓ Emergency / parking brake. 1 circuit spring activated, failsafe, hydraulically released, electrically controlled

#### Topside access:

- ✓ Hinged steps + handle

#### Technical data:

- |   |                             |
|---|-----------------------------|
| ✓ length – without tow-hitches                    | 4.54 m                      |
| ✓ width   | 2.00 m                      |
| ✓ height (cabin roof)                             | 1,99 m                      |
| ✓ turning radius outside (4-wheel steering)       | 4.00 m                      |
| ✓ drawbar pull (DBP) installed                    | 107 kN                      |
| ✓ Max. towed weight, dry concrete, inclination 1% | up to aircraft MTOW 138 ton |
| ✓ Max. towed weight, wet concrete, inclination 1% | up to aircraft MTOW 95 ton  |
| ✓ weight of the tractor:                          | 11 t.                       |
| ✓ electric system                                 | 24 V                        |

#### Cabin

- ✓ Closed cabin equipped:
  - Front cabin: rubber mounbtes
  - 2 adjustable suspension seats (driver + 1 co-driver)
  - 2 safety belts for driver and co-driver (lap belts)
  - Standard doors (left + right)
  - Adjustable steering column
  - Steering wheel handle
  - 1 inside and 2 outside rear view mirrors
  - 2 intermittent windsreen wipers including washer
  - 2 rear screen wipers including washer
  - Ventilation and heating system
  - Additional heating system (Webasto)
  - Windscreen wipers
  - Sliding side windows
  - Rear view window

- Engine hour meter
  - Battery charge control
  - Hazard warning lights
  - Reverse hooter
  - Horn
  - Two 4-chamber tail lights (rear lights, stop light, turn signal lights, reversing lights)
  - Front and rear lights embedded in the chassis of with protective grating
  - Emergency button on the dashboard
- ✓ Orange rotating beacon installed on the cab tractors with protective grating
  - ✓ Protection grids for light front + rear
  - ✓ 1 each multi-stage pin-type tow hitch front + rear, pin with 35 mm and 65 mm Ø pin secured

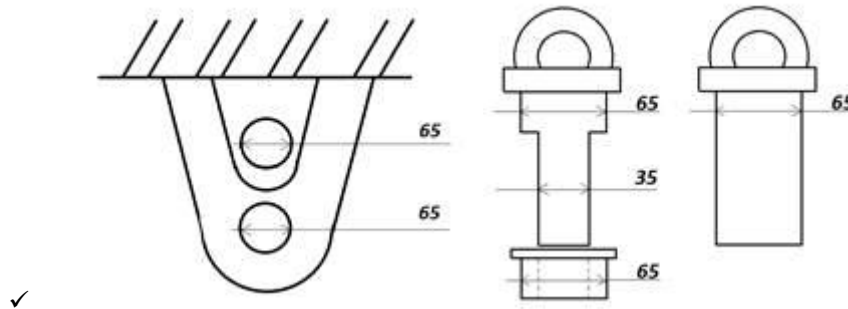

- ✓ Rear and front tow hitch with the mirror
- ✓ Rear and front tow hitch light
- ✓ Small loading platform for chocks
- ✓ Max. speed (30 kms per hour)
- ✓ Manual parking brake
- ✓ Pneumatic tyres
- ✓ Protection from the rubber material
  - at the front of the tractor
  - at the rear of the tractor
  - front and rear of the tractor
- ✓ Instruction labels in Czech language
- ✓ Extinguisher (6 kg) located in the cab behind the drivers seat.
- ✓ Painting in white RAL 9010 color without Czech Airlines Handling, a.s. logo
- ✓ The unit shall be provide according all IATA and CE regulations especially IATA AHM 955, AHM 910 , AHM 913, AHM 915, AHM 914, AHM 916 and EN 12312-7
- ✓ Documentation:
  - Two Operating and maintenance manuals in the Czech language, spare-parts catalogues, electric and hydraulic schematics in the English language.
  - Data sheet;
  - Operating and maintenance instruction;
  - Hydraulic and electric schematics;
  - Illustrate spare parts catalogue;
  - Sub - supplier information;
  - Certificate of conformity according all IATA and CE regulations especially IATA AHM 955, AHM 910 , AHM 913, AHM 915, AHM 914, AHM 916 and EN 12312-7