

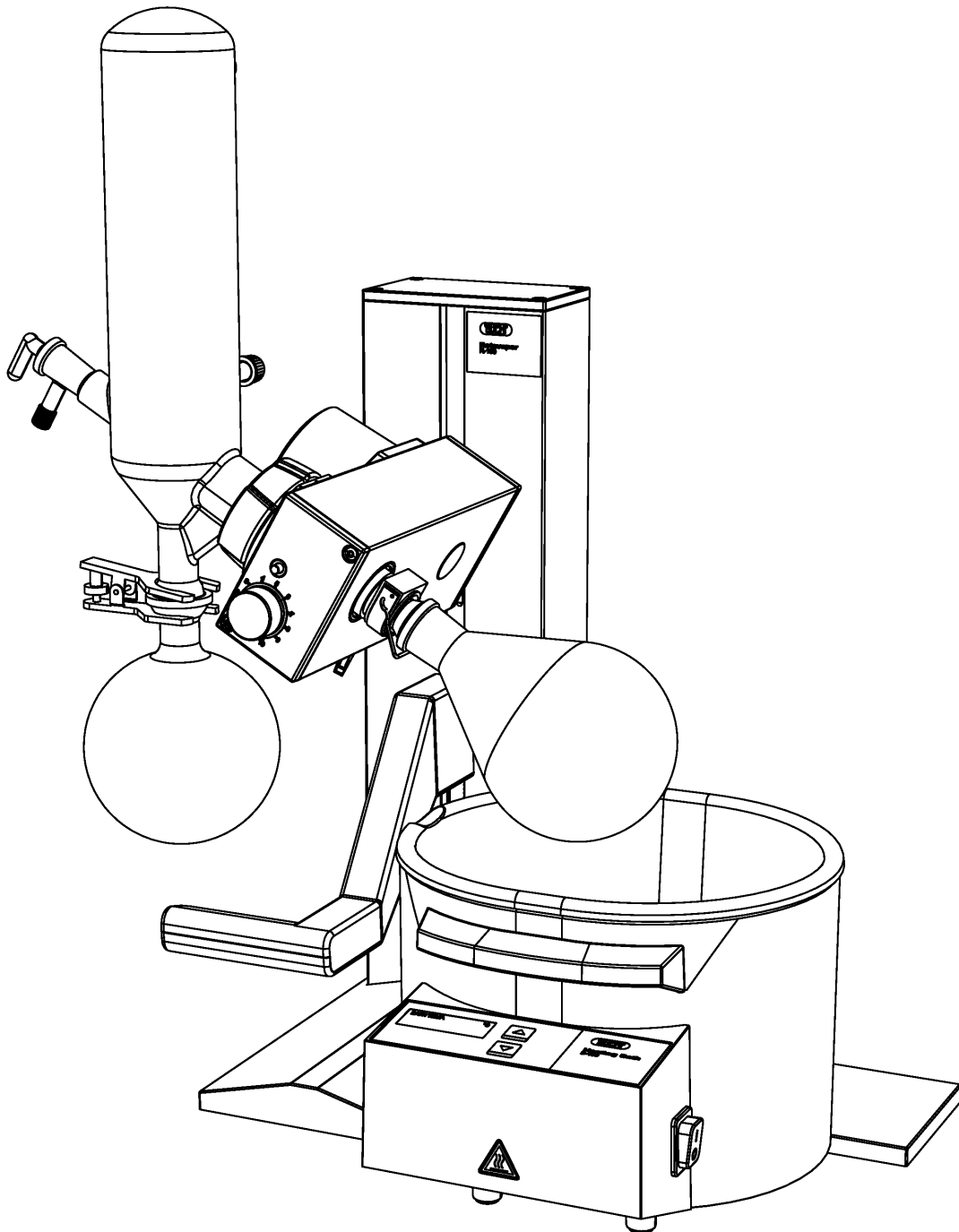

## Rotavapor® R-100

### Technical data sheet

The Rotavapor® R-100 is a high-quality rotary evaporator to meet the essential needs in classical laboratory applications. It is capable of a manually adjustable rotation speed of 20 to 280 rpm and equipped with an action jack lift for manual lifting of the evaporating flask. Included is the selected condenser, 1 L receiving and evaporating flasks and a vapor duct. All accessories are included for out of the box usage.



## Scope of delivery

All models are delivered ready to use and are complete of:

Components	Rotavapor® with glass assembly	Rotavapor® without glass assembly	Rotavapor® system
Rotavapor® R-100	1	1	1
Heating Bath B-100	1	1	1
Condenser (according to order code)	1	-	1
Vapor duct (with Combi-Clip)	1	-	1
Vacuum seal (KD22)	1	1	1
Evaporating flask (1 liter)	1	-	1
Receiving flask (1 liter)	1	-	1
Flyer "List of solvents"	1	1	1
Set of required cooling and vacuum hoses	1	-	1
Power cable	1	1	1
Interface I-100 (with power adapter)	-	-	1
Vacuum Pump V-100	-	-	1
Recirculating Chiller F-100 / F-105	-	-	*

(\*according to oder code)

## Order code

Choose the configuration according to your needs:

Rotavapor® with glass assembly

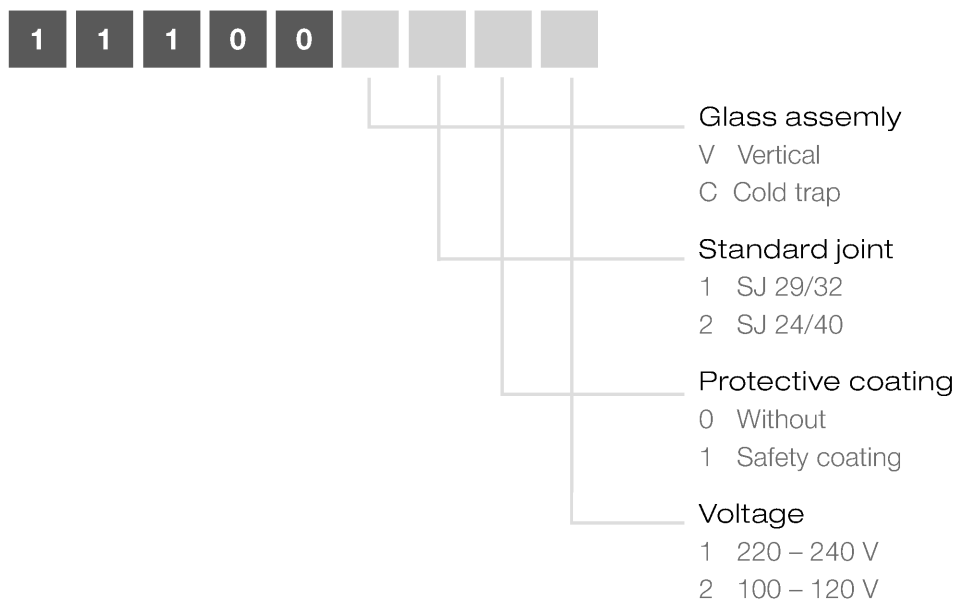

## Rotavapor® without glass assembly

**1 1 1 0 0 N 0 0 1** Rotavapor® R-100, w/o glass, 220 – 240 V

**1 1 1 0 0 N 0 0 2** Rotavapor® R-100, w/o glass, 100 – 120 V

**1 1 0 6 1 7 7 2** Rotavapor® R-100, w/o heating bath, w/o glass, 100 – 240 V\*

\* without power adapter

## Rotavapor® Systems

The rotary evaporator system R-100 meets the essential needs in laboratory evaporation. It is bundled with the Vacuum Pump V-100 regulated by the Interface I-100 and can optionally include the Recirculating Chiller F-100 or F-105. All accessories and tubes are included for out of the box usage.

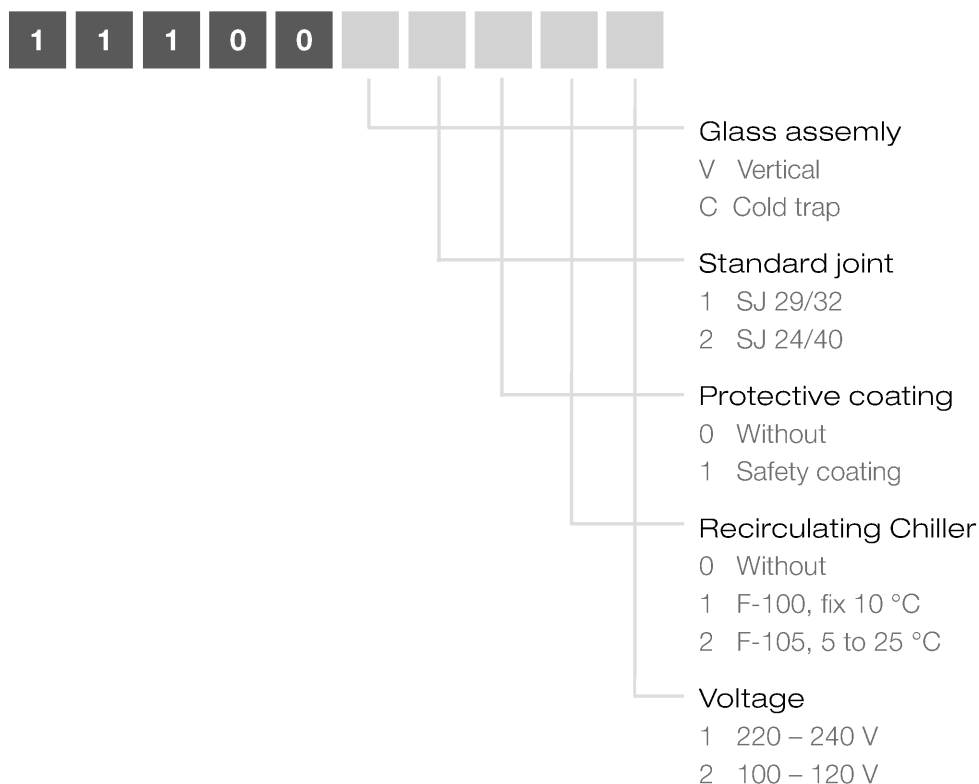

## Description of glass assemblies

Abbr.	Type / application	Cooling surface area
V	Vertical condenser For standard applications. The most common condenser. No top hole.	1460 cm <sup>2</sup>
C	Dry ice condenser For distillation of solvents with low boiling points. No cooling water is necessary.	500 cm <sup>2</sup>

## Dimensions

	Dimensions (W x H x D)
Rotavapor® R-100 with condenser (V or C), with heating bath	617 x 898 x 502 mm
Rotavapor® R-100 without condenser, with heating bath	480 x 626 x 502 mm

## Technical data

	Rotavapor® R-100 (incl. Heating Bath B-100)
Weight (depending on glass assembly)	18 – 19 kg
Operating voltage	24 V
Frequency	DC
Power consumption	30 W, connected to Heating Bath B-100
Protection class	IP21
Angle adjustable	0 – 35 °
Stroke distance	150 mm (+ 100 mm extendable)
Rotation speed	20 – 280 rpm
Flask size range	50 – 4000 mL
Maximum flask capacity	3 kg
Approval	CE

	Heating Bath B-100
Dimension (WxHxD)	285 x 219 x 326 mm
Weight	4.0 kg
Operation voltage (according to order code)	100 – 120 V or 220 – 240 V
Frequency	50/60 Hz
Power consumption	1700 W
Heating Power	1300 W
Protection class	IP21
Controlled temperature range	20 – 95 °C
Maximum flask size	4000 mL
Temperature regulation accuracy	± 2 °C
Approval	CE

## Special features

### Rotavapor® R-100

Lift extension	Up to 100 mm allows use of bump traps and glass extenders
Stop-end position limiter	Manually adjustable prevents glass breakage and damage to bath pan
Multifunctional Combi-Clip	Tool for evaporating flask fixation and removal as well as vapor duct release

### Heating Bath B-100

Temperature display	Digital allows adjusting set temperature and indicates actual temperature
Over-temperature protection	Power cut off when actual temperature exceeds set temperature or by rapid temperature increase
Carry handles	Two integrated handles facilitate carry, re-filling and emptying the heating bath
Bath guidance	Integrated in the Rotavapor® base Allows to easily position the heating bath along the guidance (sideways) when various evaporating flasks are used

## Complementary products

See respective product brochures and technical data sheets for more information.

	Pump V-100	Chiller F-100	Chiller F-105
R-100	autonomous	autonomous	manually controlled
R-100 with I-100	regulated	autonomous	regulated temperature manually controlled*

\*Recirculating Chiller F-105 is switched ON and OFF automatically via Interface I-100

## Exemplary solution

The following items are listed based on the solution “Rotavapor® Essential”, shown in the “Laboratory Evaporation Solutions” brochure.

Rotavapor® R-100, SJ29/32, V, 220-240V	11100V1021
Interface I-100	
Vacuum Pump V-100	
Recirculating Chiller F-105	
Woulff bottle	

## Rotavapor accessories

	Order number
Heating Bath, B-100, 220-240V	11061895
Heating Bath, B-100, 100-120V	11061894
Protective shield, for Heating bath B-491, B-100 Effective user protection against splashing	048052
Top cover, for Heating bath B-491, B-100 To cover bath when not in use to save energy and to reduce evaporation of heating media	048230
Swimming balls, PP, Ø10mm (450pcs) To reduce energy consumption of heating bath and for less evaporation of heat media, for temperatures up to 100°C	036405
Cooling water valve, 24VAC Valve opens cooling water feed only during distillation	031356
Water jet pump, B-764, magnetic valve, FFKM backstroke valve, 24V Simple principle of vacuum generation, without cooling water valve, only used in combination with a vacuum controller or interface	031358
Water jet pump, B-767, magnetic valve (2 pcs), FFKM backstroke valve, 24V Simple principle of vacuum generation, for pump and cooling water, only used in combination with a vacuum controller or interface	031357
Water regulation nozzle, restrictor valve, hose clamp, sieve Used when tap water is applied as vacuum source, to reduce flow-rate of the water	011606
Stopcock, standard, SJ18.8/38 For aeration of the system	040627
Stopcock, classic, SJ18.8/38 For aeration of the system, less cross-contamination than standard stopcock (040627)	000637
Stopcock, PTFE, SJ18.8/38 For applications when grease should be avoided, used instead of standard stopcock (040627), no feeding possible	023896
Flask holder, ring, non-slippery EPDM Keeps flasks stable on the lab bench, for round-bottom flasks (50 - 5000 mL)	048618
Set of flask holders, non-slippery EPDM (5pcs) Keeps flasks stable on the lab bench, for round-bottom flasks (50 - 5000 mL)	11059916
Power adapter, 24VDC, operating range 100-240V, frequency 50/60Hz For operation of Rotavapor® without heating bath	11055312

	Order number
Lab grease, tube, grease Glisseal 40 blue (60g) To grease the joints	048197
Condenser holder, holding rod, screw (2pcs), rubber band Recommended to fasten condenser onto Rotavapor® R-100, for V- and C-glass assembly	052893
Tubing, for vacuum, silicone rubber, Ø6/16mm, red, per m	017622
Tubing, for vacuum, PTFE (rigid), Ø8/10mm, white/transparent, per m	027277
Tubing, for vacuum, PEP, Ø6/8mm, transparent, per m	027900
Tubing, for cooling media, Nyflex, PVC-P, Ø8/14mm, transparent, per m	004113
Tubing, for cooling media, silicone rubber, Ø6/9mm, transparent, per m	004133
Tubing, for feed, PTFE, Ø4.7/5.5mm, 330mm	000646

### Rotavapor® wear parts

	Order number
Vacuum seal, KD22, PTFE-composite	000636
Vacuum seal, KD22, PTFE-compensite, FDA-compliant sealing material	11056622
Hose barb, bent, GL14, silicone seal	018916
Set of hose barbs, bent, GL14, silicone seal, incl. cap nut (4pcs each)	037287
Set of hose barbs, bent, GL14, FPM seal, incl. cap nut (4pcs each)	040295
Set of hose barbs, bent, GL14, EPDM seal, incl. cap nut (4pcs each)	043129
Set of hose barbs, straight, GL14, silicone seal, incl. cap nut (4pcs each)	037642
Set of hose barbs, straight, GL14, FPM seal, incl. cap nut (4pcs each)	040296
Set of hose barbs, straight, GL14, EPDM seal, incl. cap nut (4pcs each)	043128
Set of hose barbs, bent (1pc), straight (1pc), GL14, silicone seal, incl. cap nut (2pcs)	041939
Set of hose barbs, bent (4pcs), straight (2pcs), GL14, silicone seal, incl. cap nut (6pcs)	038000
Set of hose barbs, bent, GL14, silicone seal (3pcs each)	041987
Set of cap nuts, screw cap with hole, incl. FEP seal (10pcs)	041999
Set of cap nuts, screw cap with hole, GL14 (10pcs)	041956
Set of cap nuts, screw cap without hole, GL14 (5pcs)	040624
Set of seals, for hose barb, GL14, silicone, red (20pcs)	040023
Set of seals, for hose barb, GL14, FPM, green (10pcs)*	040040
Set of seals, for hose barb, GL14, EPDM, black (10pcs)*	040029
Seal GL14, for cap nut, GL14, FEP	038225

\* FPM and EPDM seals are more chemical resistant than silicone seals

## Rotavapor® glass assemblies

The following items have to be purchased in addition to a system that is ordered without glass.

All glass assemblies include a liter receiving flask, required hoses and a ball joint clamp. Evaporating flask, vacuum seal, vapor duct (KD22) and condenser holder are not included.

	Order number
Glass assembly V complete	11057056
Glass assembly V complete, P+G safety coating Receiving flask with P+G safety coating	11057057
Glass assembly C complete	040640
Glass assembly C complete, P+G safety coating Receiving flask with P+G-LT safety coating	040642

## Rotavapor® glass accessories

	SJ 29/32	SJ 24/40
Vapor duct compatible with KD22	032339	032341

## Additional glassware

Additional glassware like evaporating flasks, drying flasks, receiving flasks, beaker flasks, Reitmeyer adapters (bump traps) and distillation spiders can be found in the "Laboratory Evaporation Glassware" brochure.