

Příloha č.2 Zadávací dokumentace
Technická specifikace

Část 3 veřejné zakázky "Měřicí systém pro přechodové děje"

Měřicí ústředna pro analogové signály								
Požadované parametry								
počet číslic	konfigurovatelný počet 2vodičových kanálů	konfigurovatelný počet 4vodičových kanálů	rychlost přepínání DCV	přepínání pomocí relé (nikoli polovodičem)	komunikace RS232 nebo USB	měření napětí ac/dc, odpor, frekvence, termočlánky J,K,T s kompenzací, 4vodičové zapojení odporových teploměrů	basic dcv accuracy (1 V, 10 V ranges, one year), per cent	max. switched voltage
minimálně 6 1/2	minimálně 40	minimálně 20	minimálně 50 ch/s	jedině ANO	jedině ANO	jedině ANO	maximálně 0,005%	minimálně 300 V

Parametry nabízeného zařízení Keysight Technologies 34970A se dvěma moduly 34901A								
6 1/2	40	20	60 ch/s	ano	ano	ano	0,004% of reading + 0,0007% of range	300 V

Velmi přesný digitální multimetr								
Požadované parametry								
počet číslic	nejmenší rozsah DC napětí	max. napětí DC	nejmenší rozsah AC napětí (RMS)	max. AC napětí (RMS)	počet odečtů za sekundu	komunikace RS232 nebo USB	odpor 2vodičově a 4vodičově, kapacita, frekvence, 4vodičové zapojení odporových teploměrů	DCV přesnost pro rozsahy 1 V a 10 V, jeden rok
minimálně	maximálně	minimálně	maximálně	minimálně	minimálně	jedině	všechny	maximálně
7,5	100 mV	1000 V	100 mV	700 V	50 kS/s	ANO	ANO	20 ppm of reading + 4 ppm of range

Parametry nabízeného zařízení Keysight Technologies 34470A								
7,5	100 mV	1000 V	100 mV	750 V	50 kS/s	ano	ano	20 ppm of reading + 4 ppm of range

Keysight 34970A Data Acquisition/Switch Unit Family

34970A

34972A

Technical Overview



At a fraction of the cost of other standalone data acquisition systems

- 3-slot mainframe with built-in 6½ digit DMM and
- 8 optional switch and control plug-in modules
- Measures and converts 11 different input signals: temperature with thermocouples, RTDs and thermistors; dc/ac volts; 2- and 4-wire resistance; frequency and period; dc/ac current
- IO options for easy connectivity to your PC:
 - 34970A: GPIB, RS-232
 - 34972A: LAN, USB
- Graphical Web interface for point and click monitor and control (34972A)
- USB flash drive support to copy/log data in standalone applications (34972A)
- Includes BenchLink Data Logger Software to configure and control tests, display results and collect data for further analysis

Table of Contents

Features	03
More Power and Flexibility than You Ever Imagined You Could Afford	06
The Keysight 34970A/34972A Offers Unequaled Versatility for Your Data Acquisition Applications	07
A powerful, flexible data acquisition system for automated test	10
ATE feature checklist	11
Low-cost, high-quality switching for automated test	12
Customize your Keysight 34970A/34972A with plug-in modules	13
34970A and 34972A Keysight modules-at-a-glance selection guide	13
Keysight quality	14
Spec interpretation guide	15
34970A/34972A accuracy specifications ±(% of reading + % of range)[1]	16
Single channel reading rates to I/O or internal memory	18
System specifications	19
Modules specifications	20
Multiplexer selection guide	21
34901A	21
34902A	22
34908A	22
34903A	23
34904A	23
34905A 50 Ω/34906A 75 Ω	24
34907A	25
Rack mounting and dimensions	26
Ordering Information	27



Features

Price and performance beyond compare

Go ahead and compare the Keysight Technologies, Inc. 34970A and 34972A Data Acquisition/Switch Units with other data acquisition systems currently available. You'll find it hard to come up with a system that offers the powerful measurement performance, flexibility, connectivity options and ease of use of the 34970A/34972A—even in systems costing three to five times as much.

What can you expect from a data acquisition system that's this affordable?

Measurements you can trust

We took the measurement engine from our best-selling benchtop DMM and embedded it inside a 3-slot mainframe. You get the benefit of proven Keysight measurement performance, universal inputs with built-in signal conditioning, and modular flexibility, all in a low-cost, compact data acquisition package. The 34970A/34972A features 6½ digits (22 bits) of resolution, 0.004% basic dcV accuracy, and ultra-low reading noise. Combine that with scan rates of up to 250 channels/sec, and you've got the speed and accuracy you need to get the job done right the first time.

Built-in signal conditioning to get your job done

Whether you need to measure temperature, ac/dc volts, resistance, frequency, or current, the 34970A/34972A can handle it.

The internal autoranging DMM directly measures 11 different functions, eliminating the need for expensive external signal conditioning. And our unique design allows complete per channel configurability for maximum flexibility and quick, easy set up. It's like having an independent, high-performance DMM behind each channel.

Standard connectivity to the PC

Whether you use GPIB, RS-232, LAN or USB interfaces, the 34970A/34972A family offers easy connection to the PC. The 34970A offers traditional GPIB and RS-232 interfaces. The 34972A has built-in Gigabit LAN and USB 2.0 so you can connect to a modern PC without having to purchase any GPIB cards, cables or converter boxes. With the standard LAN connections you also get the added benefit of a graphical Web interface for easy configuration of measurements and monitoring of results using a standard Web browser.

Convenient data storage with USB flash drive

The 34972A also features a built-in USB memory port so that you can use a USB flash drive to upload BenchLink Data Logger configurations into the 34972A and collect data without being connected to a PC. Data can be logged directly to the USB flash drive, extending your instrument's memory, or copied from internal memory for transfer to a computer in another location.



Easy to use graphical Web interface (34972A only)

The built-in graphical Web interface provides easy access and control of the instrument using a Java-enabled Web browser such as Internet Explorer. Using this interface you can configure measurements, define and execute scan lists, or monitor measurement results from anywhere on the network. Simply enter the instrument host name or IP address into the browser URL and gain access to the instrument's capabilities with simple point and click control right in your browser.

- Specify per channel measurement configuration
- Define and execute scan lists
- Open, close, or monitor switch positions
- Monitor measurement readings
- View and save data
- Send SCPI commands and view IO command log
- View error queue
- View instrument information like module configuration, relay counts, firmware revisions, and more

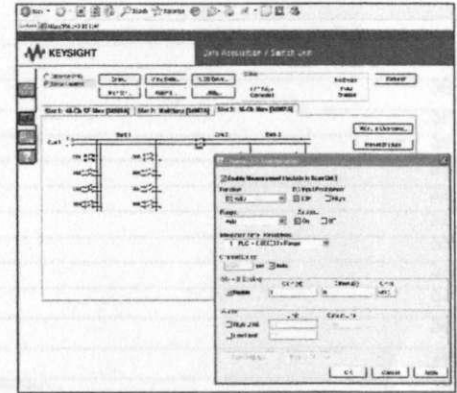

Additionally, since the Web interface is built into the instrument, you can access it on any operating system that supports a Web browser without having to install any special software.

Password protection and LAN lock out are also provided to limit access. The graphical Web interface makes it easy to configure measurements, set up and execute scans or troubleshoot your designs from anywhere on the network.

Free BenchLink Data Logger software saves you time and money

Now you don't have to spend your valuable time writing or configuring software. Keysight BenchLink Data Logger 3 software gives you a familiar Microsoft Windows interface for test configuration and real-time data display and analysis. Even better, the data logging application is included with every standard Keysight 34970A/34972A.

Also available

The BenchLink Data Logger Pro Software adds limit checking and decision making for more complex applications. Simply identify the measurements you want to acquire, define limits and actions to be performed, and then initiate the process. Your data is then collected, evaluated and acted on real-time.

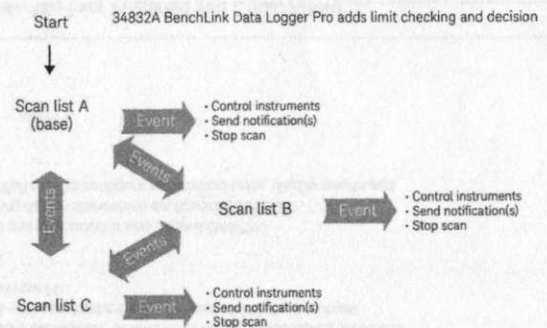

Unequaled ease of use

From the simplified configuration to the graphical Web interface in the 34972A, we put in extra time and energy so you don't have to. Simple things like on-module screw-terminal connectors, built-in thermocouple reference junctions, well-organized user documentation full of examples and hints, and a standard Getting Started kit that will have you making measurements in just a few minutes all add up to increased productivity, whether you use the instrument every day or only now and then.

Custom configurations that grow with you

Three module slots and eight switch/control modules allow you to customize the 34970A/34972A to meet your unique requirements. Buy only what you need—and add more modules later as your application grows.

34970A and 34972A are compatible

The 34972A LXI Data Acquisition/Switch Unit is an LXI version of the 34970A. It replaces the GPIB and RS-232 interfaces with modern connectivity for a direct connection to your PC or Laptop.

The 8 plug-in modules can be used with either unit—so all the measurements and wiring are compatible. The 34972A can be easily integrated into an existing test program with a simple change to the instrument address. Since the 34972A code is a superset of the 34970A code, once the instrument address is changed, the test program will run as normal.

Example:

Change:
Set inst1.IO = ioMgr.Open("GPIB0::9::INSTR")

To:
Set inst1.IO = ioMgr.Open("TCPIP0::156.140.77.230::inst0::INSTR")

	34970A	34972A
Support 8 plug-in modules	<input type="checkbox"/>	<input type="checkbox"/>
LabView drivers	<input type="checkbox"/>	<input type="checkbox"/>
IVI-C, IVI-COM drivers	<input type="checkbox"/>	<input type="checkbox"/>
BenchLink Data Logger	<input type="checkbox"/>	<input type="checkbox"/>
Optional BenchLink Data Logger Pro	<input type="checkbox"/>	<input type="checkbox"/>
Graphical Web interface	<input type="checkbox"/>	<input type="checkbox"/>
Gigabit LAN	<input type="checkbox"/>	<input type="checkbox"/>
USB 2.0	<input type="checkbox"/>	<input type="checkbox"/>
USB memory port	<input type="checkbox"/>	<input type="checkbox"/>
GPIB	<input type="checkbox"/>	<input type="checkbox"/>
RS-232	<input type="checkbox"/>	<input type="checkbox"/>

More Power and Flexibility than You Ever Imagined You Could Afford

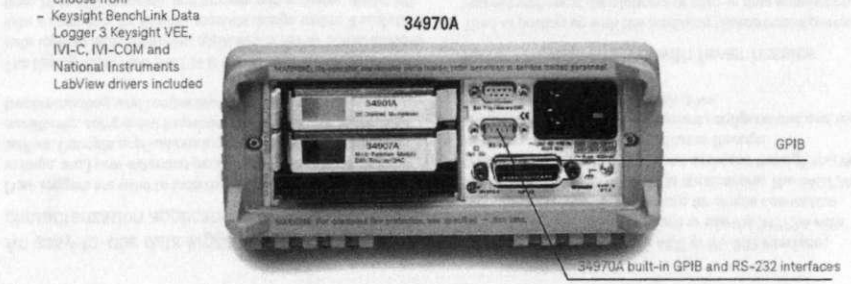
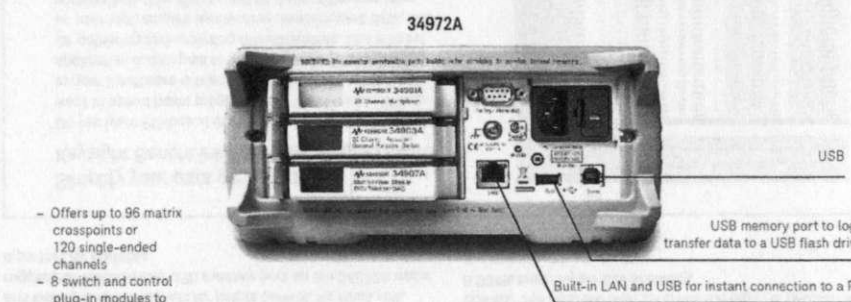
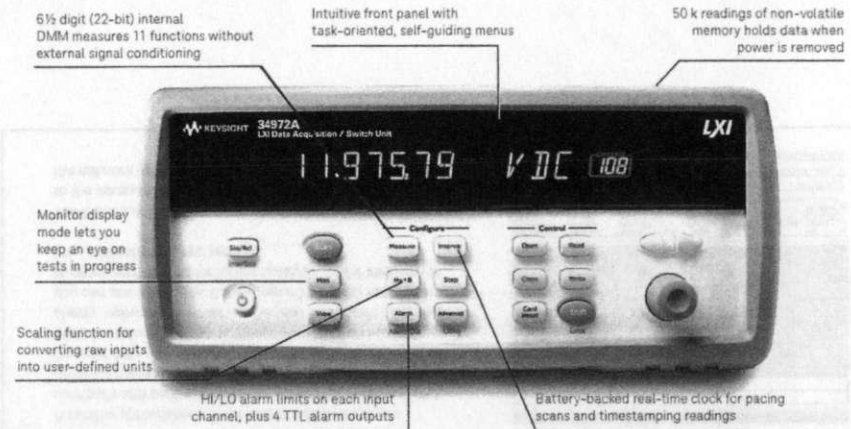

The Keysight 34970A/34972A Offers Unequaled Versatility for Your Data Acquisition Applications

In the past, you had to make a choice. On the one hand, you could choose the simple operation and low cost of a data logger. On the other hand, you had the flexibility and higher performance of a modular data acquisition system. The Keysight 34970A/34972A Data Acquisition/Switch Unit gives you the best of both worlds: a simple user interface with low per-channel cost, modular flexibility, standard connectivity and impressive measurement performance.

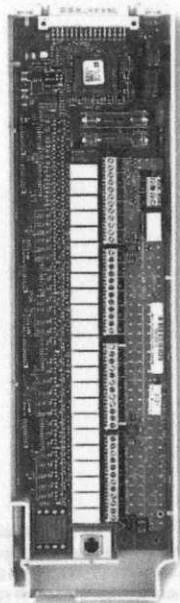

Whether you're an R&D engineer working on characterizing your latest design, or a manufacturing engineer building a test system or troubleshooting a process, the 34970A/34972A Data Acquisition/Switch Unit offers the best combination of price and measurement performance.

It's a data logger

Configured with a 20-channel relay multiplexer, the 34970A/34972A becomes a powerful, low-cost data logger for simple characterization applications. What's more, the 34972A with its LAN and USB interfaces is ideal for easy set up and control for data logging applications in remote locations. For more information on using the 34970A/34972A for data logging applications, see page 8.

It's a data acquisition front end

The 34970A/34972A is an automated test system with excellent measurement performance—it's got the accuracy, resolution, and speed you need. See page 10 for application information.

It's a switch system

Order the mainframe without the internal DMM and you've got an even lower cost, high-quality signal routing solution. See page 12 for details.

An easy-to-use data logger for monitoring and characterization applications

Data loggers are used to monitor multiple signals (temperature, voltage, etc.) over extended periods of time to identify irregularities. Example applications include environmental chamber monitoring, component inspection, benchtop testing, process troubleshooting, and temperature profiling.

The Keysight 34970A/34972A is easy to use for a multitude of data logging and monitoring applications, either stand-alone or with a computer. Its flexible, modular design makes it scalable from 20 to 120 channels, and lets you add actuator, digital I/O, and analog output channels for simple control. Its small size, ruggedized features and USB memory port on the 34972A make it perfect for portable

applications. Use GPIB (IEEE 488) or RS-232 interfaces in the 34970A for legacy systems or use the 34972A with standard LAN and USB interfaces for simple connection to the PC and support of remote applications. The 34972A can be set up at remote locations and accessed through the Web interface on a network connection or through the USB port by copying instrument configurations and measurement data results to a USB flash drive.

Better measurements with fewer hassles

Tired of putting up with the mediocre measurement performance you get with most data loggers or plug-in data acquisition boards? The 34970A/34972A offers 6½ digits of resolution and 0.004% basic 1-year dcV accuracy.

Simplify your data gathering with Keysight BenchLink Data Logger 3 software

Do you want PC-based data logging capability, but don't want to spend hours programming? The BenchLink Data Logger 3 software is the answer. This Windows-based application is designed to make it a snap to use your PC for gathering and analyzing measurements. Use it to set up your test, acquire and archive measurement data, and perform real-time display and analysis of the incoming measurements.

A familiar spreadsheet environment makes it easy to configure and control your tests. And a rich set of colorful graphics provides many options for analyzing and displaying your data—all with point-and-click ease. Set up multiple graphics using strip charts, histograms, bar and scatter charts, individual channel results, and more. And of course you can use BenchLink Data Logger 3 to easily move data to other applications for further analysis, or for inclusion in your presentations and reports.

The BenchLink Data Logger software can run connected to the computer, standalone in the instrument or even over the network when using the LAN interface on the 34972A.

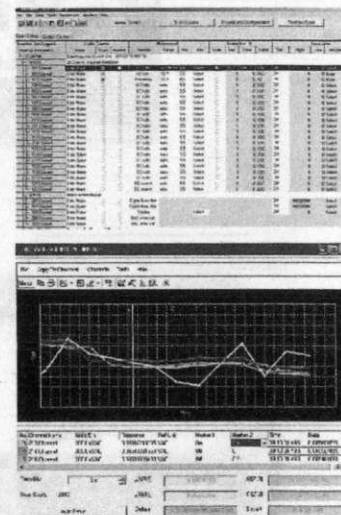

And the 34970A/34972A measures and converts 11 different input signals:

- Temperature with thermocouples, RTDs, and thermistors
- dc and ac volts
- 2- and 4-wire resistance
- Frequency and period
- dc and ac current

What's more, each channel is independently configurable. This means you can configure channel 1—for dcV, channel 2 for a K-type thermocouple, and channels 3 and 13 for a 4-wire RTD measurement—all on the same module, all in a single scan. For custom linear conversions, use the Mx+B scaling function on any channel. You can even display a custom 3-character engineering label like RPM or PSI to identify your measurement units.

Versatile alarms

Alarms are available on a per-channel basis as well. Enter a high limit, a low limit, or both. The 34970A/34972A compares each reading to its limits and flags any out-of-range measurements. You can assign one of four TTL alarm outputs to any input channel to trigger external alarm lights, sirens, or send a TTL pulse to your control system, all without a PC connected.

Scanning made simple

The 34970A/34972A automatically builds a scan list that includes all configured inputs (even digital inputs from the Keysight 34907A multifunction module) in ascending order by channel number. You can pace scans by setting the 34970A/34972A's internal timer for automatic scanning at a specific interval, by manually pressing a front-panel button, or by sending a software command or external TTL trigger pulse.

Monitor any input

A special display mode monitors a selected input channel, continuously updating the display with new readings—even during a scan. Or, when using the 34972A with built-in LAN, the channels can be monitored over the network using the graphical Web interface. It's great for keeping an eye on a key input, or for troubleshooting your system before a test.

Non-volatile memory and USB flash drive adds convenience, portability

All readings are automatically time-stamped and stored in a nonvolatile 50,000 reading memory—enough memory to hold more than a week's worth of data (20 channels scanned every five minutes). The nonvolatile memory holds your data even after power is removed, so you can use the 34970A/34972A to collect data at a remote location for later uploading to a PC. Or if you need even more memory, the 34972A's USB port can be used to log data directly to a USB flash drive or to copy the data from the reading memory without being connected to a computer.

Data logging feature checklist

- From 1 to 120 channels of analog input
- Measurements include dc volts, ac volts, thermocouple, thermistor and RTD temperature measurements, 2- and 4-wire Ohms, dc current, ac current, frequency, and period
- 6½ digits (22 bits) of resolution with 0.004% basic 1-year dcV accuracy
- 50 k reading nonvolatile memory including time-stamp
- Scaling and alarms available on each channel
- Full-featured front panel for stand-alone configuration, troubleshooting, and data viewing
- BenchLink Data Logger 3 software for configuration and data analysis
- Nonvolatile storage for five complete instrument states
- Built-in LAN or USB interfaces to support remote data logging applications (34972A only)

A powerful, flexible data acquisition system for automated test

The 34970A/34972A gives you the resolution, accuracy, repeatability, and speed you've come to expect from a Keysight data acquisition system. It provides the measurement muscle you need, along with signal routing and control capability, in a flexible, modular format that can grow and change to match your varied applications.

Powerful measurements

The internal 6½ digit DMM brings the power and performance of a world-class stand-alone DMM to the 34970A/34972A, but at a fraction of the cost and in a fraction of the space. It's as accurate as the best bench DMM available: 0.004% basic 1-year dcV accuracy, 0.06% basic 1-year acV accuracy, and 0.01% basic 1-year resistance accuracy. Our patented Multi-slope III A-D technology offers incredible linearity (2 ppm of reading +1 ppm of range) along with 22 bits of real resolution. And since it is an integrating A/D, it provides excellent noise rejection as well—a nice change from noisy PC plug-ins and sampling A/Ds. No more averaging lots of samples just to see the real data you wanted. And if you need high scan rates, the 34970A/34972A is capable of delivering fully converted measurements at speeds up to 250 ch/s.

The input section of the DMM is optically isolated and shielded from the 34970A/34972A's earth-referenced circuitry and computer interface, offering up to 300 V of input isolation. This is important for reducing ground loop and common mode voltage errors associated with long wiring runs and floating measurement sources.

Flexible functionality

The DMM is installed inside the chassis rather than in one of the slots, leaving all three mainframe slots free for switch and control modules. You can choose from eight different modules (see page 13) to get the precise functionality you need now—while giving you flexibility for future expansion.

The internal DMM gives you the flexibility to measure 11 types of inputs easily and inexpensively. The built-in signal conditioning and conversion routines turn raw inputs directly into real information. Each measurement channel is independently configurable, so you can set different measurement functions, scale factors and alarm limits, even on adjacent channels. Advanced measurement features such as offset compensation, variable integration time, and delay are also selectable on a per-channel basis.

Get better measurements with built-in signal conditioning

The Keysight 34970A/34972A architecture offers advantages over other data acquisition solutions which rely on external or plug-in signal conditioning modules for handling functions other than dcV:

- Minimizes external wiring and the resultant potential for noise and errors to enter your system
- Reduces hidden costs and overall system cost by avoiding unnecessary cables, breakout boxes and signal conditioning elements
- Simplifies your configuration—for faster, easier setup—with fewer connections and components
- Takes the guesswork out of error analysis.
- Measurement accuracies are specified to include all system-related errors
- Improves reliability, with fewer interconnects and fewer parts that can fail

Software drivers

Your months of test system software development time need not go to waste. Software drivers that support (C, C#, Visual Basic, Visual Studio), Keysight VEE and National Instruments LabView are available for the 34970A/34972A to make integration into your test system easy. Standard RS-232 and GPIB interfaces on the 34970A or LAN and USB on the 34972A and SCPI programming language make integration even easier.

ATE feature checklist

- 3-slot cardcage with 6½ digit (22 bit) internal DMM 0.004% basic 1-year dcV accuracy; 0.06% acV accuracy
- Up to 120 single-ended measurements or 96 matrix crosspoints in a 3½" high, half-rack instrument
- Eight switch and control modules include low-frequency and RF multiplexers, matrix and actuation switches, digital input and output, analog output, and event recording
- Scan rates up to 250 ch/s
- GPIB and 115 kbaud RS-232 interfaces standard (34970A)
- Graphical Web interface to speed up test development and monitor tests remotely (34972A)
- Software drivers available to support Keysight VEE and National Instruments LabView
- Relay maintenance feature for system maintenance



Compact 60-channel data acquisition system

Low-cost, high-quality switching for automated test

If you don't need the built-in measurement capability of the 34970A/34972A, save money by ordering it without the DMM. What you end up with is the lowest cost switch unit on the market. It's an ideal solution for routing test signals to and from your DUT and assorted instruments, including external DMMs, scopes, counters, and power supplies. Plus, you can add the DMM later if your needs change.

The functionality you need

We put a lot of thought into defining and designing the modules for the 34970A/34972A in order to cover a broad spectrum of switching and signal routing requirements with fewer modules. The result? Simplified ordering and easier configuration. And while we were at it, we improved performance and density. The 34970A/34972A modules can switch from microvolts to 300 volts, dc to 2 GHz, and with densities as high as 120 single-ended channels or 96 matrix crosspoints per frame. Plus, simple control capabilities like analog outputs, open collector digital outputs, and isolated Form-C relays for controlling higher-powered devices are available.

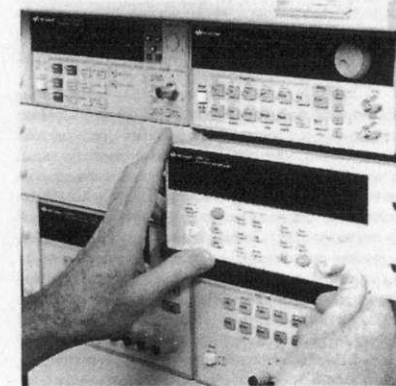

Low-cost switching system for automated testing

Easy scanning

The 34970A/34972A can easily scan with external instruments. It builds a scan list that includes all enabled low frequency multiplexer inputs. Scans are controlled with the external channel advance input, or with the front panel Step key.

Connect to the company network

With the 34972A's LAN interface, the instrument is easily connected to the company network to collect measurement data to a central database, remotely access the instrument's set up, or monitor measurement data from anywhere on the network.

Customize your Keysight 34970A/34972A with plug-in modules

A complete selection of plug-in modules gives you high quality measurement, switching, and control capabilities to choose from. Modules include both low-frequency and RF multiplexers, a matrix switch, a general-purpose switch, and a multifunction module that includes digital input/output, analog output, and totalizer capabilities. You can mix and match modules to get just the functionality you need right now—then change or add more channels later as your application grows.

Modules for the 34970A/34972A are designed to make your testing easier, faster, and more reliable. Here's how:

Higher throughput

Our unique architecture incorporates a high-performance microprocessor on each module, off loading the mainframe processor and minimizing backplane communications for faster throughput.

More channels in less space

Surface mount construction and a highly integrated design minimize the space required for relay drive and interface circuitry. High density on-module connectors save both board and connector space normally required by a terminal block. We use the latest technology to squeeze the most out of the remaining board space, giving you up to 40 single-ended channels in roughly the same space used by many data acquisition system terminal blocks.

Convenient connections

On-module screw-terminal connectors make wiring more convenient. Built-in strain relief cable routing and cable tie points keep your wiring secure and safe from accidental tugs and pulls. An internal analog bus routes signals from any of the low frequency multiplexers directly to the internal DMM, without the need for external connections.

Use the chart below to help you pinpoint the modules that meet your needs.

34970A and 34972A Keysight modules-at-a-glance selection guide

Model description	Type	Speed (ch/sec)	Max volts	Max amps	Bandwidth	Thermal offset	Comments	Page
34901A 20 ch Multiplexer + 2 current channels	2-wire armature (4-wire selectable)	60	300 V	1 A	10 MHz	< 3 μ V	Built-in cold junction reference 2 additional current channels (22 total)	21
34902A 16 ch Multiplexer	2-wire reed (4-wire selectable)	250 ^[1]	300 V	50 mA	10 MHz	< 6 μ V	Built-in cold junction reference	21
34903A 20 ch Actuator/GP Switch	SPDT/form C	120	300 V	1 A	10 MHz	< 3 μ V		23
34904A 4 x 8 Matrix	2-wire armature	120	300 V	1 A	10 MHz	< 3 μ V		23
34905A Dual 4 ch RF Mux 50 Ω	Common low (unterminated)	60	42 V	0.7 A	2 GHz	< 6 μ V	1 GHz bandwidth through BNC-to-SMB adapter cable	24
34906A Dual 4 ch RF Mux 75 Ω	Common low (unterminated)	60	42 V	0.7 A	2 GHz	< 6 μ V	1 GHz bandwidth through BNC-to-SMB adapter cable	24
34907A Multifunction Module	Two 8-bit digital I/O ports		42 V	400 mA			Open drain	25
	26-bit event counter		42 V		100 KHz		Selectable input threshold	
	Two 16-bit analog outputs		\pm 12 V	10 mA	dc		Max 40 mA total output per frame	
34908A 40 ch Single-Ended Mux	1-wire armature (common low)	60	300 V	1 A	10 MHz	< 3 μ V	Built-in cold junction reference No four-wire measurements	21

[1] Up to 250 ch/sec to internal memory.
See scanning rates for measurement condition and rate on each instrument.

Keysight quality

We know you can't afford instrument downtime due to hardware failures and unscheduled maintenance. That's why our engineers designed reliability into the 34970A/34972A: A rugged enclosure, state-of-the-art surface mount construction throughout, reduced parts counts, and rigorous and thorough testing on all aspects of the product.

Take the guesswork out of relay maintenance

The 34970A/34972A uses our proprietary relay maintenance system to help you to predict relay end-of-life and avoid costly production line downtime. It automatically counts every individual switch closure and stores it in nonvolatile memory on each module. You can query the total number of cycles on any individual channel so you can schedule maintenance and avoid erratic end-of-life failures.

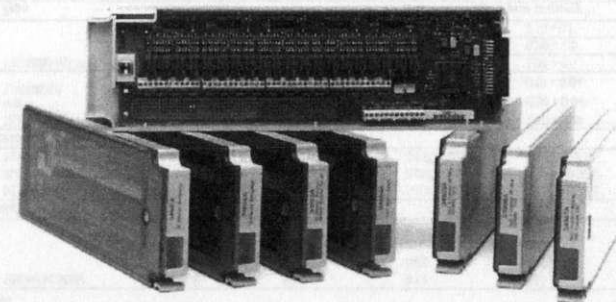

Spec interpretation guide

The following pages list the technical specifications for the Keysight 34970A/34972A Data Acquisition/Switch Unit and its modules. The explanations and examples below are helpful in understanding how to interpret these specifications:

- Measurement accuracy is specified as percent of reading plus percent of range, where reading is the actual measured value and range is the name of the scale (1 V, 10 V, etc.)—not the full scale value (1.2 V, 12 V, etc.).
- DMM measurement accuracies include all switching errors. Switching errors are also listed separately in the module specifications section. Temperature measurement accuracies include ITS-90 conversion errors. The thermocouple accuracies include the reference junction error as well.
- Accuracies are listed as either 24-hour, 90-day, or 1-year specifications. This refers to the length of time since the instrument's last calibration. Use the specification that matches your calibration cycle. The 24-hour specifications are useful for determining short-term relative performance.

Example 1: Basic dcV accuracy

Calculate the accuracy of the following measurement:

- 9 V dc input
- 10 V dc range
- 1-year accuracy specifications
- Normal operating temperature (18 - 28°C)

From the following page, the 1-year accuracy is: 0.0035% of reading + 0.0005% of range

Which translates into:
 $(0.0035/100 \times 9 \text{ V}) + (0.0005/100 \times 10 \text{ V}) = 365 \mu\text{V}$

For a total accuracy of:
 $365 \mu\text{V}/9 \text{ V} = 0.0041\%$

Example 2: Extreme operating temperature

When the 34970A/34972A is used outside of its 18 - 28°C temperature range, there are additional temperature drift errors to consider. Assume the same conditions in Example 1, but at a 35°C operating temperature.

The basic accuracy is again:
 0.0035% of reading + 0.0005% of range = 365 μV.

Now, multiply the 10 V temperature coefficient from the following page by the number of degrees outside of operating range for additional error:
 $(0.0005\% \text{ reading} + 0.0001\% \text{ range})$
 $/^\circ\text{C} \times (35 - 28^\circ\text{C}) =$
 $(0.0005\% \text{ reading} + 0.0001\% \text{ range})$
 $/^\circ\text{C} \times 7^\circ\text{C} =$
 0.0035% reading + 0.0007% range = 385 μV
 Total error is then:
 $365 \mu\text{V} + 385 \mu\text{V} = 750 \mu\text{V}$ or 0.008%

Example 3: Thermocouple measurement accuracy

Calculating the total thermocouple reading error is easy with the 34970A/34972A—just add the listed measurement accuracy to the accuracy of your transducer. Switching, conversion, and reference junction errors are already included in the measurement specification.

For this example, assume a J-type thermocouple input reading 150°C.

From the following page, total error is:
 Thermocouple probe accuracy + 1.0°C
 The probe vendor specifies accuracy of 1.1°C
 or 0.4%, whichever is greater.

Total error is then:
 $1.0^\circ\text{C} + 1.1^\circ\text{C} = 2.1^\circ\text{C}$ total, or 1.4%

Example 4: acV accuracy

The acV function measures the true RMS value of the input waveform, regardless of waveshape. Listed accuracies assume a sine wave input. To adjust accuracies for non-sinusoids, use the listed crest factor adder.

For this example, assume a ± 1 V square wave input with 50% duty cycle and a 1 kHz frequency.

Accuracy for 1 V, 1 kHz sinusoid is:
 0.06% reading + 0.04% range
 A 50% duty cycle squarewave has a crest factor of
 Peak value / RMS value = $1 \text{ V} / 1 \text{ V} = 1$

From crest factor table, add:
 0.05% of reading
 The total accuracy is:
 $0.11\% \text{ of reading} + 0.04\% \text{ of range} = 1.5 \text{ mV}$ or 0.15%

34970A/34972A accuracy specifications ±(% of reading + % of range)^[1]

Includes measurement error, switching error, and transducer conversion error

	Range ^[3]	Frequency, etc.	24 hour ^[2] 23 ±1°C	90 Day 23 ±5°C	1 Year 23 ±5°C	Temperature coefficient 0 - 18°C, 28 - 55°C		
DC voltage	100.0000 mV		0.0030 + 0.0035	0.0040 + 0.0040	0.0050 + 0.0040	0.0005 + 0.0005		
	1.000000 V		0.0020 + 0.0006	0.0030 + 0.0007	0.0040 + 0.0007	0.0005 + 0.0001		
	10.00000 V		0.0015 + 0.0004	0.0020 + 0.0005	0.0035 + 0.0005	0.0005 + 0.0001		
	100.0000 V		0.0020 + 0.0006	0.0035 + 0.0006	0.0045 + 0.0006	0.0005 + 0.0001		
	300.0000 V		0.0020 + 0.0020	0.0035 + 0.0030	0.0045 + 0.0030	0.0005 + 0.0003		
True RMS AC voltage^[4]	All ranges from 100.0000 mV to 100.0000 V	3 Hz-5 Hz	1.00 + 0.03	1.00 + 0.04	1.00 + 0.04	0.100 + 0.004		
		5 Hz-10 Hz	0.35 + 0.03	0.35 + 0.04	0.35 + 0.04	0.035 + 0.004		
		10 Hz-20 kHz	0.04 + 0.03	0.05 + 0.04	0.06 + 0.04	0.005 + 0.004		
		20 kHz-50 kHz	0.10 + 0.05	0.11 + 0.05	0.12 + 0.05	0.011 + 0.005		
		50 kHz-100 kHz	0.55 + 0.08	0.60 + 0.08	0.60 + 0.08	0.060 + 0.008		
	300.0000 V	100 kHz-300 kHz ^[5]	4.00 + 0.50	4.00 + 0.50	4.00 + 0.50	0.20 + 0.02		
		3 Hz-5 Hz	1.00 + 0.05	1.00 + 0.08	1.00 + 0.08	0.100 + 0.008		
		5 Hz-10 Hz	0.35 + 0.05	0.35 + 0.08	0.35 + 0.08	0.035 + 0.008		
		10 Hz-20 kHz	0.04 + 0.05	0.05 + 0.08	0.06 + 0.08	0.005 + 0.008		
		20 kHz-50 kHz	0.10 + 0.10	0.11 + 0.12	0.12 + 0.12	0.011 + 0.012		
Resistance^[6]	100.0000 Ω	1 mA current source	0.0030 + 0.0035	0.008 + 0.004	0.010 + 0.004	0.0006 + 0.0005		
		1 mA	0.0020 + 0.0006	0.008 + 0.001	0.010 + 0.001	0.0006 + 0.0001		
		100 μA	0.0020 + 0.0005	0.008 + 0.001	0.010 + 0.001	0.0006 + 0.0001		
		10 μA	0.0020 + 0.0005	0.008 + 0.001	0.010 + 0.001	0.0006 + 0.0001		
100.0000 MΩ	5.0 μA	0.002 + 0.001	0.008 + 0.001	0.010 + 0.001	0.0010 + 0.0002			
	500 nA	0.015 + 0.001	0.020 + 0.001	0.040 + 0.001	0.0030 + 0.0004			
	100.0000 MΩ	0.300 + 0.010	0.800 + 0.010	0.800 + 0.010	0.1500 + 0.0002			
	500 nA 10 MΩ							
Frequency and period^[7]	100 mV to 300V	3 Hz-5 Hz	0.10	0.10	0.10	0.005		
		5 Hz-10 Hz	0.05	0.05	0.05	0.005		
		10 Hz-40 Hz	0.03	0.03	0.03	0.001		
		40 Hz-300 kHz	0.006	0.01	0.01	0.001		
DC current (34901A only)	10.00000 mA	<0.1 V burden	0.005 + 0.010	0.030 + 0.020	0.050 + 0.020	0.002 + 0.0020		
		<0.5 V	0.010 + 0.004	0.030 + 0.005	0.050 + 0.005	0.002 + 0.0005		
		<2 V	0.050 + 0.006	0.080 + 0.010	0.100 + 0.010	0.005 + 0.0010		
True RMS AC current (34901A only)	10.00000 mA and ^[8]	3 Hz-5 Hz	1.00 + 0.04	1.00 + 0.04	1.00 + 0.04	0.100 + 0.006		
		5 Hz-10 Hz	0.30 + 0.04	0.30 + 0.04	0.30 + 0.04	0.035 + 0.006		
		10 Hz-5 kHz	0.10 + 0.04	0.10 + 0.04	0.10 + 0.04	0.015 + 0.006		
	100.0000 mA ^[9]	3 Hz-5 Hz	1.00 + 0.5	1.00 + 0.5	1.00 + 0.5	0.100 + 0.06		
		5 Hz-10 Hz	0.30 + 0.5	0.30 + 0.5	0.30 + 0.5	0.035 + 0.06		
Temperature	Type	1-year accuracy ^[10]			Extended range 1-year accuracy ^[10]		Temp coefficient/°C	
		Thermocouple ^[10]	B	1100 to 1820°C	1.2°C	400 to 1100°C		1.8°C
			E	-150 to 1000°C	1.0°C	-200 to -150°C		1.5°C
			J	-150 to 1200°C	1.0°C	-210 to -150°C		1.2°C
			K	-100 to 1200°C	1.0°C	-200 to -100°C		1.5°C
			N	-100 to 1300°C	1.0°C	-200 to -100°C		1.5°C
			R	300 to 1760°C	1.2°C	-50 to 300°C		1.8°C
			S	400 to 1760°C	1.2°C	-50 to 400°C		1.8°C
			T	-100 to 400°C	1.0°C	-200 to -100°C		1.5°C
			RTD	R0 from 49 Ω to 2.1 kΩ	-200 to 600°C	0.06°C		
Thermistor	2.2 k, 5 k, 10 k			-80 to 150°C	0.08°C		0.002°C	

[1] Specifications are for 1 hr warm-up and 6½ digits, Slow ac filter
 [2] Relative to calibration standards
 [3] 20% over range on all ranges except 300 Vdc and ac ranges and 1 Adc and ac current ranges
 [4] For sinewave input > 5% of range. For inputs from 1% to 5% of range and < 50 kHz, add 0.1% of range additional error
 [5] Typically 30% of reading error at 1 MHz, limited to 1 x 108 V Hz
 [6] Specifications are for 4-wire ohms function or 2-wire ohms using scaling to remove the offset. Without scaling, add 4 Ω additional error in 2-wire Ohms function
 [7] Input > 100 mV. For 10 mV to 100 mV inputs multiply % of reading error x 10
 [8] Specified only for inputs > 10 mA
 [9] For total measurement accuracy, add temperature probe error
 [10] Thermocouple specifications not guaranteed when 34907A module is present. For < 1°C accuracy, a precision external reference is required.

Spec interpretation guide

The following pages list the technical specifications for the Keysight 34970A/34972A Data Acquisition/Switch Unit and its modules. The explanations and examples below are helpful in understanding how to interpret these specifications:

- Measurement accuracy is specified as percent of reading plus percent of range, where reading is the actual measured value and range is the name of the scale (1 V, 10 V, etc.)—not the full scale value (1.2 V, 12 V, etc.).
- DMM measurement accuracies include all switching errors. Switching errors are also listed separately in the module specifications section. Temperature measurement accuracies include ITS-90 conversion errors. The thermocouple accuracies include the reference junction error as well.
- Accuracies are listed as either 24-hour, 90-day, or 1-year specifications. This refers to the length of time since the instrument's last calibration. Use the specification that matches your calibration cycle. The 24-hour specifications are useful for determining short-term relative performance.

Example 1: Basic dcV accuracy

Calculate the accuracy of the following measurement:

- 9 V dc input
- 10 V dc range
- 1-year accuracy specifications
- Normal operating temperature (18 - 28°C)

From the following page, the 1-year accuracy is: 0.0035% of reading + 0.0005% of range

Which translates into:
(0.0035/100 x 9 V) + (0.0005/100 x 10 V) = 365 µV

For a total accuracy of:
365 µV/9 V = 0.0041%

Example 2: Extreme operating temperature

When the 34970A/34972A is used outside of its 18 - 28°C temperature range, there are additional temperature drift errors to consider. Assume the same conditions in Example 1, but at a 35°C operating temperature.

The basic accuracy is again:
0.0035% of reading + 0.0005% of range = 365 µV.

Now, multiply the 10 V temperature coefficient from the following page by the number of degrees outside of operating range for additional error:

(0.0005% reading + 0.0001% range)

/°C x (35 - 28°C) =

(0.0005% reading + 0.0001% range)

/°C x 7°C =

0.0035% reading + 0.0007% range = 385 µV

Total error is then:

365 µV + 385 µV = 750 µV or 0.008%

Example 3: Thermocouple measurement accuracy

Calculating the total thermocouple reading error is easy with the 34970A/34972A—just add the listed measurement accuracy to the accuracy of your transducer. Switching, conversion, and reference junction errors are already included in the measurement specification.

For this example, assume a J-type thermocouple input reading 150°C.

From the following page, total error is:
Thermocouple probe accuracy + 1.0°C

The probe vendor specifies accuracy of 1.1°C or 0.4%, whichever is greater.

Total error is then:
1.0°C + 1.1°C = 2.1°C total, or 1.4%

Example 4: acV accuracy

The acV function measures the true RMS value of the input waveform, regardless of waveshape. Listed accuracies assume a sine wave input. To adjust accuracies for non-sinusoids, use the listed crest factor adder.

For this example, assume a ± 1 V square wave input with 50% duty cycle and a 1 kHz frequency.

Accuracy for 1 V, 1 kHz sinusoid is:

0.06% reading + 0.04% range

A 50% duty cycle square wave has a crest factor of

Peak value / RMS value = 1 V / 1 V = 1

From crest factor table, add:

0.05% of reading

The total accuracy is:

0.11% of reading + 0.04% of range = 1.5 mV or 0.15%

34970A/34972A accuracy specifications ±(% of reading + % of range)^[1]

Includes measurement error, switching error, and transducer conversion error

DC voltage	Range ^[2]	Frequency, etc.	24 hour ^[2] 23 ±1°C	90 Day 23 ±5°C	1 Year 23 ±5°C	Temperature coefficient 0 - 18°C, 28 - 55°C
	100.0000 mV		0.0030 + 0.0035	0.0040 + 0.0040	0.0050 + 0.0040	0.0005 + 0.0005
	1.000000 V		0.0020 + 0.0006	0.0030 + 0.0007	0.0040 + 0.0007	0.0005 + 0.0001
	10.00000 V		0.0015 + 0.0004	0.0020 + 0.0005	0.0035 + 0.0005	0.0005 + 0.0001
	100.0000 V		0.0020 + 0.0006	0.0035 + 0.0006	0.0045 + 0.0006	0.0005 + 0.0001
	300.000 V		0.0020 + 0.0020	0.0035 + 0.0030	0.0045 + 0.0030	0.0005 + 0.0003
True RMS AC voltage^[4]						
	All ranges from 100.0000 mV to 100.0000 V	3 Hz-5 Hz	1.00 + 0.03	1.00 + 0.04	1.00 + 0.04	0.100 + 0.004
		5 Hz-10 Hz	0.35 + 0.03	0.35 + 0.04	0.35 + 0.04	0.035 + 0.004
		10 Hz-20 kHz	0.04 + 0.03	0.05 + 0.04	0.06 + 0.04	0.005 + 0.004
		20 kHz-50 kHz	0.10 + 0.05	0.11 + 0.05	0.12 + 0.05	0.011 + 0.005
		50 kHz-100 kHz	0.55 + 0.08	0.60 + 0.08	0.60 + 0.08	0.060 + 0.008
		100 kHz-300 kHz ^[5]	4.00 + 0.50	4.00 + 0.50	4.00 + 0.50	0.20 + 0.02
	300.0000 V	3 Hz-5 Hz	1.00 + 0.05	1.00 + 0.08	1.00 + 0.08	0.100 + 0.008
		5 Hz-10 Hz	0.35 + 0.05	0.35 + 0.08	0.35 + 0.08	0.035 + 0.008
		10 Hz-20 kHz	0.04 + 0.05	0.05 + 0.08	0.06 + 0.08	0.005 + 0.008
		20 kHz-50 kHz	0.10 + 0.10	0.11 + 0.12	0.12 + 0.12	0.011 + 0.012
		50 kHz-100 kHz	0.55 + 0.20	0.60 + 0.20	0.60 + 0.20	0.060 + 0.020
		100 kHz-300 kHz ^[5]	4.00 + 1.25	4.00 + 1.25	4.00 + 1.25	0.20 + 0.05
Resistance^[6]						
	100.0000 Ω	1 mA current source	0.0030 + 0.0035	0.008 + 0.004	0.010 + 0.004	0.0006 + 0.0005
	1.000000 kΩ	1 mA	0.0020 + 0.0006	0.008 + 0.001	0.010 + 0.001	0.0006 + 0.0001
	10.00000 kΩ	100 µA	0.0020 + 0.0005	0.008 + 0.001	0.010 + 0.001	0.0006 + 0.0001
	100.0000 kΩ	10 µA	0.0020 + 0.0005	0.008 + 0.001	0.010 + 0.001	0.0006 + 0.0001
	1.000000 MΩ	5.0 µA	0.002 + 0.001	0.008 + 0.001	0.010 + 0.001	0.0010 + 0.0002
	10.00000 MΩ	500 nA	0.015 + 0.001	0.020 + 0.001	0.040 + 0.001	0.0030 + 0.0004
	100.0000 MΩ	500 nA 10 MΩ	0.300 + 0.010	0.800 + 0.010	0.800 + 0.010	0.1500 + 0.0002
Frequency and period^[7]						
	100 mV to 300V	3 Hz-5 Hz	0.10	0.10	0.10	0.005
		5 Hz-10 Hz	0.05	0.05	0.05	0.005
		10 Hz-40 Hz	0.03	0.03	0.03	0.001
		40 Hz-300 kHz	0.006	0.01	0.01	0.001
DC current (34901A only)						
	10.00000 mA	<0.1 V burden	0.005 + 0.010	0.030 + 0.020	0.050 + 0.020	0.002 + 0.0020
	100.0000 mA	<0.6 V	0.010 + 0.004	0.030 + 0.005	0.050 + 0.005	0.002 + 0.0005
	1.000000 A	<2 V	0.050 + 0.006	0.080 + 0.010	0.100 + 0.010	0.005 + 0.0010
True RMS AC current (34901A only)						
	10.00000 mA and ^[8]	3 Hz-5 Hz	1.00 + 0.04	1.00 + 0.04	1.00 + 0.04	0.100 + 0.006
	1.000000 A	5 Hz-10 Hz	0.30 + 0.04	0.30 + 0.04	0.30 + 0.04	0.035 + 0.006
		10 Hz-5 kHz	0.10 + 0.04	0.10 + 0.04	0.10 + 0.04	0.015 + 0.006
	100.0000 mA ^[9]	3 Hz-5 Hz	1.00 + 0.5	1.00 + 0.5	1.00 + 0.5	0.100 + 0.06
		5 Hz-10 Hz	0.30 + 0.5	0.30 + 0.5	0.30 + 0.5	0.035 + 0.06
		10 Hz-5 kHz	0.10 + 0.5	0.10 + 0.5	0.10 + 0.5	0.015 + 0.06
Temperature	Type	1-year accuracy^[10]	Extended range 1-year accuracy^[10]		Temp coefficient/°C	
Thermocouple^[10]	B	1100 to 1820°C	1.2°C	400 to 1100°C	1.8°C	
	E	-150 to 1000°C	1.0°C	-200 to -150°C	1.5°C	
	J	-150 to 1200°C	1.0°C	-210 to -150°C	1.2°C	
	K	-100 to 1200°C	1.0°C	-200 to -100°C	1.5°C	
	N	-100 to 1300°C	1.0°C	-200 to -100°C	1.5°C	
	R	300 to 1760°C	1.2°C	-50 to 300°C	1.8°C	
	S	400 to 1760°C	1.2°C	-50 to 400°C	1.8°C	
	T	-100 to 400°C	1.0°C	-200 to -100°C	1.5°C	
RTD	R0 from 49 Ω to 2.1 kΩ	-200 to 600°C	0.06°C		0.003°C	
Thermistor	2.2 k, 5 k, 10 k	-80 to 150°C	0.08°C		0.002°C	

[1] Specifications are for 1 hr warm-up and 6½ digits, Slow ac filter
 [2] Relative to calibration standards
 [3] 20% over range on all ranges except 300 Vdc and ac ranges and 1 Adc and ac current ranges
 [4] For sine wave input > 5% of range. For inputs from 1% to 5% of range and < 50 kHz, add 0.1% of range additional error
 [5] Typically 30% of reading error at 1 MHz, limited to 1 x 108 V Hz

[6] Specifications are for 4-wire ohms function or 2-wire ohms using scaling to remove the offset. Without scaling, add 4 Ω additional error in 2-wire Ohms function
 [7] Input > 100 mV. For 10 mV to 100 mV inputs multiply % of reading error x 10
 [8] Specified only for inputs >10 mA
 [9] For total measurement accuracy, add temperature probe error
 [10] Thermocouple specifications not guaranteed when 34907A module is present. For < 1°C accuracy, a precision external reference is required.

Measurement characteristics^[7]

DC voltage	
Measurement Method	Continuously Integrating Multi-slope III A-D converter
A/D linearity	0.0002% of reading + 0.0001 % of range
Input resistance	Selectable 10 MΩ or > 10,000 MΩ
100 mV, 1 V, 10 V ranges	10 MΩ ±1%
100 V, 300 V ranges	< 30 pA at 25°C
Input bias current	300 V all ranges
Input protection	
True RMS AC voltage	
Measurement method	AC coupled True RMS – measures the AC component of the input with up to 300 Vdc of bias on any range
Crest factor	Maximum of 5:1 at Full Scale
Additional crest factor errors (non-sine wave)	Crest Factor 1-2 0.05 % of reading Crest Factor 2-3 0.15 % of reading Crest Factor 3-4 0.30 % of reading Crest Factor 4-5 0.40 % of reading
Input impedance	1 MΩ ±2% in parallel with 150 pF
Input protection	300 Vrms all ranges
Resistance	
Measurement method	Selectable 4-wire or 2-wire Ohms
Offset compensation	Current source referenced to LO input
Maximum lead resistance	Selectable on 100 Ω, 1 kΩ, 10 kΩ ranges
Input protection	10% of range per lead for 100 Ω and 1 kΩ ranges, 1 kΩ on all other ranges
300 V on all ranges	
Frequency and period	
Measurement method	Reciprocal counting technique
Voltage ranges	Same as AC Voltage function
Gate time	1s, 100 ms, or 10 ms
Measurement timeout	Selectable 3 Hz, 20 Hz, 200 Hz LF limit
DC current	
Shunt resistance	5Ω for 10 mA, 100 mA; 0.1 Ω for 1 A
Input protection	1 A 250 V fuse on 34901A module
True RMS AC current	
Measurement method	Direct coupled to the fuse and shunt, AC coupled True RMS measurement (measures the ac component only)
Shunt resistance	5 Ω for 10 mA; 0.1 Ω for 100 mA, 1 A
Input protection	1 A 250 V fuse on 34901A module
Thermocouple	
Conversion	ITS-90 software compensation
Reference junction type	Internal, Fixed, or External
Open thermocouple check	Selectable per channel, Open > 5 kΩ
Thermistor	44004, 44007, 44006 series
RTD	□ = 0.00385 (DIN) and □ = 0.00391
Measurement noise rejection 60 (50) Hz^[1]	
dc CMRR	140 dB
ac CMRR	70 dB
Integration time	Normal mode rejection^[2]
200 pic/3.33s (4s)	110 dB ^[3]
100 pic/1.67s (2s)	105 dB ^[3]
20 pic/333 ms (400 ms)	100 dB ^[3]
10 pic/167 ms (200 ms)	95 dB ^[3]
2 pic/33.3 ms (40 ms)	90 dB
1 pic/16.7 ms (20 ms)	60 dB
< 1 pic	0 dB

Operating characteristics^[4]

Single channel measurement rates ^[5]			
Function	Resolution ^[6]	34970A/34972A readings/sec	
dcV, 2-wire resistance	6½ digits (10 pic)	5 (5)	
	5½ digits (1 pic)	54 (47)	
	4½ digits (0.02 pic)	500	
Thermocouple	0.1 °C (10 pic)	6 (5)	
	0.1 °C (1 pic)	52 (47)	
	0.02 pic	280	
RTD, thermistor	0.01 °C (10 pic)	6 (5)	
	0.1 °C (1 pic)	49 (47)	
	1 °C (0.02 pic)	200	
acV	6½ Slow (3 Hz)	0.14	
	6½ Med (20 Hz)	1	
	6½ Fast (200 Hz)	8	
	6½ ^[8]	100	
Frequency, period	6½ digits (1 s gate)	1	
	5½ digits (100 ms)	9	
	4½ digits (10 ms)	70	

- [1] For 1 kΩ imbalance in LO lead
- [2] For power line frequency ±0.1%
- [3] For power line frequency ±1% use 80 dB or ±3% use 50 dB
- [4] Reading speeds for 60 Hz and (50 Hz) operation
- [5] For fixed function and range, readings to memory, scaling and alarms off, AZERO OFF, USB datalogging OFF
- [6] Maximum limit with default settling delays defeated
- [7] Isolation voltage (ch–ch, ch–earth) 300 Vdc, ac rms
- [8] 6½ digits = 22 bits, 5½ digits = 18 bits, 4½ digits = 15 bits

Single channel reading rates to I/O or internal memory

(See footnotes for conditions below)	34970A		34972A
	into memory readings/sec	to GPIB or RS232 readings/sec	to LAN, USB or memory readings/sec
Single channel ASCII readings	500	440	500
Single channel while changing scale (eg MEAS dcV 10/MEAS dcV 1)	25	25	25
Single channel while changing function (eg MEAS dcV/MEAS Ohms)	12	12	12

Scanning measurement rates to I/O or internal memory

(See footnotes for conditions below)	34970A		34972A
	into memory ch/sec	to GPIB or RS232 ch/sec	to LAN, USB or memory ch/sec
Scanning dcV or ohms channels			
34901A/34906A	60	60	60
34902A	250	210	240
34902A into and out of memory (using INIT, FETCH)	–	180	240
34902A with timestamp (using MEAS)	–	150	240
34902A with scaling and alarms	220	190	220
34902A dcV and ohms on alternate channels	80	80	80
Scanning acV channels^[7]			
34901A/34908A	50	50	50
34902A	100	90	100
Scanning temperature – thermistor or TC channels			
34901A/34908A	50	50	50
34902A	160	150	150
Scanning digital in/totalizer channels			
34907A Digital Input	275	250	275
34907A Totalizer	240	210	240

Data out of memory^{[3],[4]}

(FETCH of 50K readings) (See footnotes for conditions below)	34970A		34972A	
	over GPIB readings/sec	over RS232 readings/sec	over USB readings/sec	over LAN or memory readings/sec
Readings	600	600	55 K	120 K
Readings with timestamp	450	320	35 K	60 K
Readings with all format options ON	310	230	25 K	50 K

- [1] Speeds are for 4 1/2 digits, delay 0, display off, USB data logging off, autozero off, auto-ranging off unless otherwise noted. Use MEAS command for best I/O performance. RS232 at 115 Kbaud.
- [2] Maximum, with default delays defeated
- [3] Assumes relative time format (time since start of scan)
- [4] Typical rates assuming lightly loaded PC and limited other traffic on I/Os. LAN rates assume use of socket connection, VXI11 will be less.
- [5] For fixed function and range, readings to memory, scaling/alarms/autozero off



System specifications

Scanning inputs	
Analog	34901A, 34902A, and 34908A multiplexer channels
Digital	34907A digital in and totalize
Scan list	Scans channels in ascending order
Scan triggering	
Source	Interval, external, button press, software, or on monitor channel alarm
Scan count	1 to 50,000 or continuous
Scan interval	0 to 99 hours; 1 ms step size
Channel delay	0 to 60 seconds per channel; 1 ms step size
External trig delay	< 300 μ s. With monitor on < 200 ms
External trig jitter	< 2 ms
Alarms	
Analog inputs	Hi, Lo, or Hi + Lo evaluated each scan
Digital inputs	34907A digital in maskable pattern match or state change 34907A totalize: Hi limit only Alarm evaluated each reading
Monitor channel	4 TTL compatible
Alarm outputs	Selectable TTL logic Hi or Lo on fail
Latency	5 ms (typical)
Memory	
Battery	34970A, 4-year typical life ^[1] 34972A User replaceable battery. Recommend replacement once a year during CAL.
Readings	50,000 internal readings with timestamp during scan Readable during scan
States	5 instrument states with user label
Alarm queue	Up to 20 events with channel number, reading, and timestamp
USB flash drive	Support FAT or FAT 32 format
System features	
Per-channel math	Individual Mx + B scaling and Min/Max/Average calculated real time
Power fail recovery	Resumes scanning automatically
Relay maintenance	Counts each relay closure and stores on module User resettable
Real-time clock	Battery-backed, 4-year typical life ^[1]
General specifications	
Power supply	100 V/120 V/220 V/240 V \pm 10%
Power line frequency	45 Hz to 65 Hz automatically sensed
Power consumption	12 W (25 VA peak)
Operating environment	Full accuracy for 0 to 55°C Full accuracy to 80% R.H. at 40°C -40 to 70°C ^[1]
Storage environment	
Weight	Net: 3.6 kg (8.0 lbs)
Safety	Conforms to CSA, UL-1244, IEC 1010 Cat I
RFI and ESD	CISPR 11, IEC 801-2/3/5/6

- [1] Storage at temperatures above 40°C will decrease battery life
 [2] Software provided on CD-ROM
 [3] Interface and driver must be purchased and installed separately
 [4] Requires VISA command library for IEEE-488

Software

Keysight 34825A BenchLink Data Logger 3 (included with option DMM) System requirements ^[2]	
Operating system	Windows Vista, XP SP2, 2000 SP4 (does not support any home editions), Adobe Acrobat Reader V5.0 or higher (to view documentation); Microsoft Internet Explorer V6.0 or higher (required when using Windows NT)
Controller	Recommend Pentium 4, 800 MHz or greater, Min: Pentium III, 500 MHz
RAM	Recommend 256 MB or greater, Min 128 MB
Disk space	Recommend 200 MB, Min 100 MB
Display	Recommend 1024 x 768 resolution, 256 colors
Computer interfaces ^[3]	
34970A	
GPIB	Keysight and National Instruments PCI-GPIB
RS-232 (Serial port)	PC COM 1-4
34972A	
LAN	10/100/1000 BaseT
USB	USB 2.0
Keysight BenchLink features	
Configuration	Spreadsheet-like channel configurations page. Upload and Download instrument configurations. Computed channels using \pm %, dB, dBm, dBV, x^2 , \sqrt , and full, $\frac{1}{2}$, or $\frac{1}{4}$ bridge strain
Graphical displays	Real-time and historical data displays Strip chart with markers and alarm indication, bar and scatter charts, Histogram with statistics, Bar meter, and Data table
Graphical controls	Sliders, switches, buttons, and LED lights
Alarm/limit testing	Start/Stop scanning on alarm condition Control 34903A relay state or 34907A digital output on alarm
Data	Real time streamed (saved) to disk Automatically export data and configurations Copy data or graphics to windows clipboard Export your selected data to .CSV, .XML, or .TXT formats
Event logging	Automatic entry of alarms and errors
Instrument driver support for programming languages	
IVI-C or IVI-COM driver	Compatible with Windows 7, Vista SP1, XP SP2 (32-bit) IO Libraries 14.1 or greater. Supports Keysight VEE, Visual Basic, C/C#, Visual Studio, National Instruments LabWindows CVI and LabVIEW
LabVIEW driver (VI)	LabVIEW 7.0 or greater
Controller	Recommend 800 MHz or greater, minimum 500 MHz.

Modules specifications

The Keysight 34970A/34972A accuracy specifications already include the switching offset and reference junction errors shown below. These errors are listed separately for determining system error with external measurement devices.

Up to three modules, in any combination, can be inserted into a single mainframe. The 34970A/34972A's internal DMM

connections are accessible only through the 34901A, 34902A, and 34908A low-frequency multiplexers.

On-module screw terminals accept wire sizes from 16 gage to 22 gage. Twenty-gage wire is recommended for high channel count applications. The 34905A and 34906A RF Multiplexers use SMB connectors. A standard set of (10) BNC-to-SMB adapter cables is provided with each RF module for convenient BNC connections.

	Multiplexer			Actuator	Matrix	RF multiplexer		Multifunction	
	34901A	34902A ^[1]	34908A	34903A	34904A	34905A	34906A	34907A	
General									
Number of channels	20 + 2 2/4 wire	16 2/4 wire	40 1 wire	20 SPDT	4 x 8 2 wire	Dual 1 x 4 50 Ω 75 Ω		See page 25 for module specifications	
Connects to internal DMM	<input type="checkbox"/>	<input type="checkbox"/>	<input type="checkbox"/>						
Scanning speed	60 ch/s	250 ch/s ^[1]	60 ch/s						
Open/close speed	120/s	120/s	70/s	120/s	120/s	60/s			
Input									
Voltage (dc, ac rms) ^[2]	300 V 1 A	300 V 50 mA	300 V 1 A	300 V 1 A	300 V 1 A	42 V 0.7 A			
Current (dc, ac rms)									
Power (W, VA)	50 W	2 W	50 W	50 W	50 W	20 W			
DC characteristics									
Offset voltage ^[3]	< 3 μ V	< 6 μ V	< 3 μ V	< 3 μ V	< 3 μ V	< 6 μ V			
Initial closed channel R ^[4]	< 1 Ω	< 1 Ω	< 1 Ω	< 1 Ω	< 1 Ω	< 0.5 Ω			
Isolation ch-ch, ch-earth	> 10 G Ω	> 10 G Ω	> 10 G Ω	> 10 G Ω	> 10 G Ω	> 1 G Ω			
AC characteristics									
Bandwidth ^[4]	10 MHz	10 MHz	10 MHz	10 MHz	10 MHz	2 GHz ^[5]	2 GHz ^[5]		
Insertion loss (dB)	10 MHz 100 MHz 500 MHz 1 GHz 1.5 GHz 2 GHz	-	-	-	-	-0.1 -0.4 -0.6 -1 -1.2 -3	-0.1 -0.4 -0.5 -1 -1.5 -2		
SWR	0-9.99 MHz 10-99.99 MHz 100-499.99 MHz 500-999.99 MHz 1-1.499 GHz 1.5-2 GHz	-	-	-	-	1.02 1.05 1.20 1.40 1.30 1.40	1.02 1.05 1.25 1.40 1.30 2.00		
ch-ch cross talk (dB) ^[4]	10 MHz 100 MHz 500 MHz 1 GHz 1.5 GHz 2 GHz	-45	-45	-18 ^[6]	-45	-33	-100 -85 -65 -55 -45 -35	-85 -75 -65 -50 -40 -35	
Risetime						< 300 ps			
Signal delay						< 3 ns			
Capacitance	HI - LO LO - Earth	< 50 pF < 80 pF	< 50 pF < 80 pF	< 50 pF < 80 pF	< 50 pF < 80 pF	< 20 pF -			
Volt-Hertz limit		10 ⁸	10 ⁸	10 ⁸	10 ⁸	10 ¹⁰			
Other									
T/C cold junction accuracy ^[4]	(typical)	0.8°C	0.8°C	0.8°C ^[6]					
Switch life	No load (typical) Rated load (typical) ^[7]	100 M 100 k	100 M 100 k	100 M 100 k	100 M 100 k	100 M 100 k	5 M 100 k	5 M 100 k	
Temperature	Operating Storage	all cards: 0 to 55°C all cards: -20 to 70°C							
Humidity	(non-condensing)	all cards: 40°C to 80% RH							

- [1] Not recommended for connection to ac line without external transient suppression. Up to 250 ch/s to internal memory. See scanning rates for measurement condition and rate on each instrument.
 [2] Channel-to-channel or channel-to-earth
 [3] Errors included in DMM measurement accuracy specifications

- [4] 50 Ω source, 50 Ω load
 [5] Bandwidth direct to card SMB connectors
 [6] Isolation within channel. 1 to 20 or 21 to 40 banks is -40 dB
 [7] Applies to resistive loads only
 [8] Thermocouple measurements not recommended with 2-503A module due to common to configuration



Multiplexer selection guide

Choose between the broad functionality of the 34901A, the high speed scanning of the 34902A, or the single-ended density of the 34908A. These three modules are the only way to connect to the 34970A/34972A internal DMM. They can be used to scan with external instruments as well.

All multiplexer modules employ break-before-make scanning, ensuring only one closed channel (or channel pair) at a time. Multiple channel closures are allowed on the 34901A and 34902A modules when not configured for scanning.

The 34908A does not allow multiple channel closures at any time.

34901A

20-Channel General Purpose Multiplexer

- 60 ch/s scanning
- Two- and four-wire scanning
- Built-in thermocouple reference junction
- 300 V switching

The Keysight 34901A is the most versatile multiplexer for general purpose scanning. It combines dense, multifunction switching with 60-channel/second scan rates to address a broad spectrum of data acquisition applications.

Two- and four-wire channels can be mixed on the same module. Two additional fused inputs (22 channels total) route up to 1 A of current to the internal DMM, allowing ac and dc current measurements without the need for external shunt resistors.

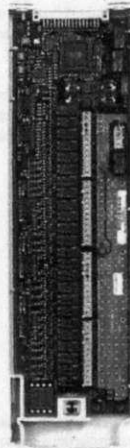

	34901A	34902A	34908A
Number of channels	20 + 2	16	40
Max scan speed	60 ch/s	250 ch/s	60 ch/s
Number of contacts	2 or 4	2 or 4	1
Temperature			
Thermocouple	<input type="checkbox"/>	<input type="checkbox"/>	<input type="checkbox"/>
2-wire RTD	<input type="checkbox"/>	<input type="checkbox"/>	<input type="checkbox"/>
4-wire RTD	<input type="checkbox"/>	<input type="checkbox"/>	<input type="checkbox"/>
Thermistor	<input type="checkbox"/>	<input type="checkbox"/>	<input type="checkbox"/>
dc Volts	<input type="checkbox"/>	<input type="checkbox"/>	<input type="checkbox"/>
ac Volts	<input type="checkbox"/>	<input type="checkbox"/>	<input type="checkbox"/>
2-wire Ohms	<input type="checkbox"/>	<input type="checkbox"/>	<input type="checkbox"/>
4-wire Ohms	<input type="checkbox"/>	<input type="checkbox"/>	<input type="checkbox"/>
Frequency	<input type="checkbox"/>	<input type="checkbox"/>	<input type="checkbox"/>
Period	<input type="checkbox"/>	<input type="checkbox"/>	<input type="checkbox"/>
dc current	<input type="checkbox"/>	<input type="checkbox"/>	<input type="checkbox"/>
ac current	<input type="checkbox"/>	<input type="checkbox"/>	<input type="checkbox"/>

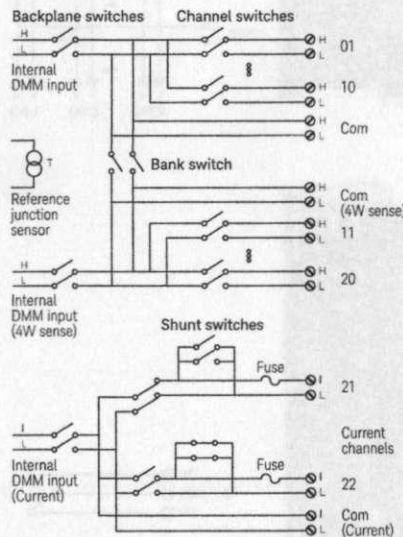

34902A

16-Channel High-Speed Multiplexer

- Scanning up to 250 ch/s
- Two- and four-wire scanning
- Built-in thermocouple reference junction

The Keysight 34902A employs reed relays to achieve scan rates up to 250 channels per second. Use this module for high-throughput automated test applications as well as high-speed data logging and monitoring tasks.

Sixteen two-wire inputs switch up to 300 V. Two- and four-wire channels may be mixed on the same module. User provided shunt resistors are required for current measurements.

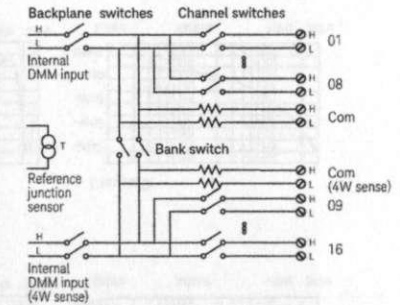
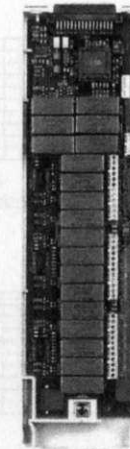

Note: Not recommended for connection to ac line without external transient suppression.

34908A

40-Channel Single-Ended Multiplexer

- 60 ch/s scanning
- Single-wire switching for common low applications
- Built-in thermocouple reference junction

Use the Keysight 34908A for the greatest density in common low applications, such as battery test, component characterization, and benchtop testing.

Each module switches 40 one-wire inputs. All two-wire internal measurements except current are supported. The module low connection is isolated from earth and can float up to 300 V.

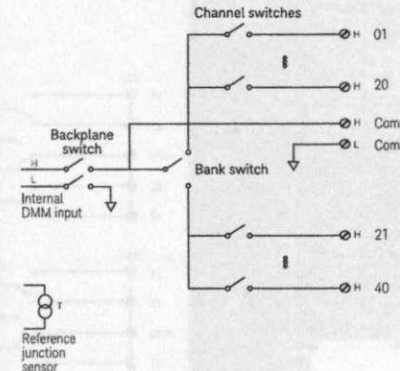
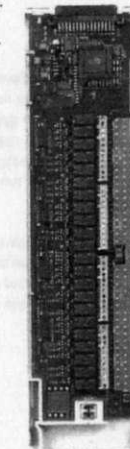

Note: Thermocouples must be electrically isolated from each other to avoid current loops and subsequent measurement errors.

34903A

20-Channel Actuator/General Purpose Switch

- SPDT (Form C) latching relays
- 300 V, 1 A actuation and control

This general purpose switch module has 20 independent single-pole, double-throw (SPDT) relays. Use it to cycle power to products under test, control indicator and status lights, and to actuate external power relays and solenoids. Combine it with matrix and multiplexer modules to build custom switch systems. Its 300 V, 1 A contacts can handle up to 50 W, enough for many power line switching applications.

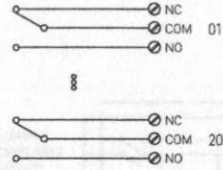

34904A

4x8 Two-wire Matrix Switch

- 32 two-wire crosspoints
- 300 V, 1 A switching

The Keysight 34904A gives you the most flexible connection path between your device under test and your test equipment, allowing different instruments to be connected to multiple points on your DUT at the same time.

Rows or columns may be connected between multiple modules to build 8x8, 4x16 or larger matrices, with up to 96 crosspoints in a single frame.

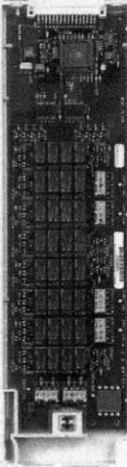
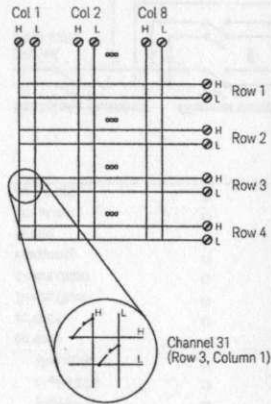

34905A 50 Ω 34906A 75 Ω

Dual 4-Channel RF Multiplexers

- 2 GHz bandwidth
- BNC to SMB adapter cables included

The Keysight 34905A and 34906A RF multiplexers offer broadband switching capabilities for high frequency and pulsed signals. Use them to route test signals between your device under test and your signal generator, oscilloscope, spectrum analyzer, or other instrumentation.

The RF multiplexers are arranged as two independent 1x4 multiplexers, each with a common shield and a switched center conductor. Connections can be made directly to SMB inputs with 2 GHz usable bandwidth, or to the BNC-to-SMB adapters provided with 1 GHz bandwidth. Multiple banks may be cascaded together for applications requiring even larger topologies—create a 16:1 multiplexer in a single frame.

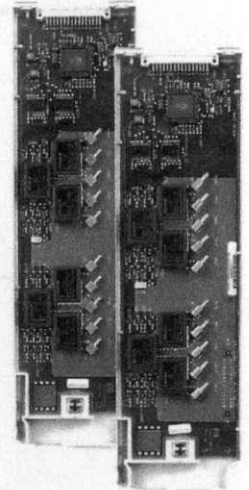
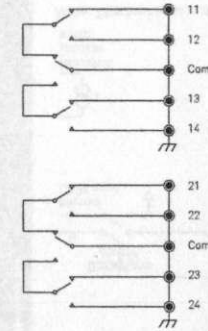

50 Ω MUX typical AC performance graphs

Insertion loss

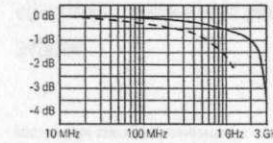

VSWR

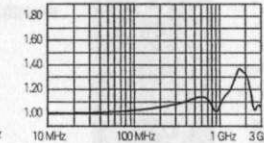

Crosstalk

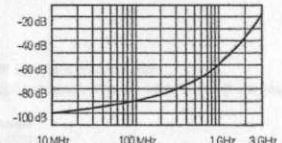

75 Ω MUX typical AC performance graphs

Insertion loss

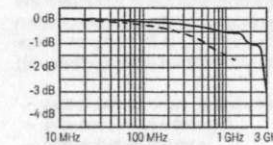

VSWR

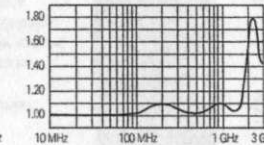

Crosstalk

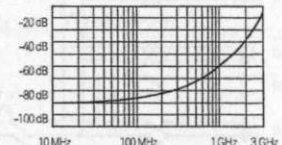

— Direct to card
 - - - - Using provided adapter cables

34907A

Multifunction Module

- 16 bits of digital input and output
- 100 kHz totalizer input
- Two ±12 V analog outputs

The Keysight 34907A allows great flexibility for a variety of sense and control applications. It combines two 8-bit ports of digital input and output, a 100 kHz gated totalizer, and two ±12 V analog outputs—all on a single earth-referenced module. The digital inputs and totalizer input may be included in a scan. Alarm limits for the digital and event counter inputs are evaluated continuously, capturing and logging alarm conditions even between scans.

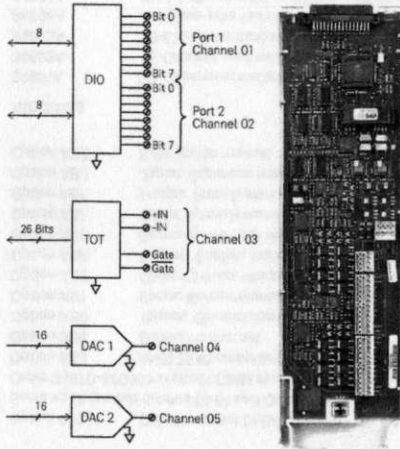

Digital input/output

Use the digital outputs with an external power supply to control microwave switches and attenuators, solenoids, power relays, indicators, and more. Use the digital inputs to sense limit switch and digital bus status. There are no complex handshake modes; reads and writes are initiated either from the front panel or the bus.

Port 1, 2	8 bit, input or output, nonisolated
Vin(L)	< 0.8 V (TTL)
Vin(H)	> 2.0 V (TTL)
Vout(L)	< 0.8 V @ Iout = -400 mA
Vout(H)	> 2.4 V @ Iout = 1 mA
Vin(H) max	< 42 V with external open drain pull-up
Alarming	Maskable pattern match or state change
Speed	4 ms (max) alarm sampling
Latency	5 ms (typical) to 34970A alarm output
Read/write speed	95/s

Totalize input

Count events from devices like photo interrupters, limit switches, and Hall-effect sensors.

It keeps an updated total which can be read via the front panel or programmatically at any time. With 26 bits of resolution, it can count events at full speed for nearly 11 minutes without an overflow.

Max count	2 ²⁶ - 1
Totalize input	100 kHz (max) Rising or falling edge, programmable
Signal level	1 Vp-p (min) 42 Vpk (max)
Threshold	0 V or TTL, jumper selectable
Gate Input	TTL-Hi, TTL-Lo, or none
Count reset	Manual or Read + Reset
Read speed	85/s

Analog output

Use the two electronically calibrated analog outputs to source bias voltages to your device under test, to control your analog programmable power supplies, or use the outputs as setpoints for your control systems. The outputs are programmed directly in volts, either from the front panel or from the bus.

DAC 1, 2	±12 V, nonisolated
Resolution	1 mV
IOUT	10 mA max
Settling time	1 ms to 0.01% of output
Accuracy	±(% of output + mV)
1 year ±5°C	0.25% + 20 mV
Temp. coefficient	±(0.015% + 1 mV)/°C

Rack mounting and dimensions

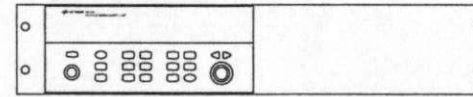

To rack mount a single instrument, order adapter kit 34190A.

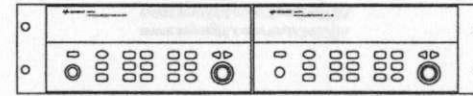

To rack mount two instruments side-by-side, order 34191A 2U dual flange kit and 34194A dual lock link kit.

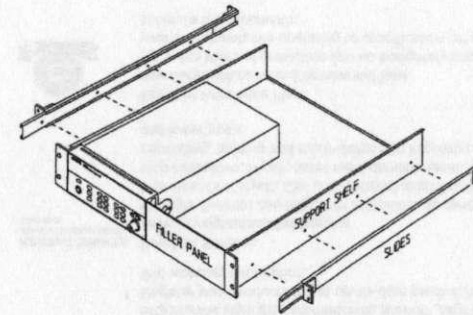

To install one or two instruments in a sliding support shelf, order shelf 5063-9255, and slide kit 1494-0015 (for single instrument, also order filler panel 5002-3999).

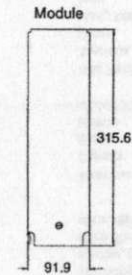
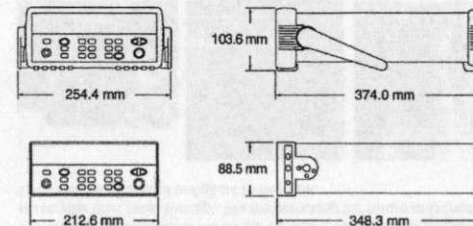

Ordering Information

Mainframe

34970A	Data Acquisition/Switch Unit with RS-232 and GPIB
34972A	Data Acquisition/Switch Unit with LAN and USB

Both mainframes include internal 6 1/2 digit DMM, test report, power cord, thermocouple, and screwdriver. Included CD ROM has Keysight BenchLink DataLogger3 software, IVI-COM and VXI PnP Drivers, Example Code Wizard, Programmers Reference Help File, Users Guide, Quick Start Tutorial and Service Guide. Modules are purchased separately and are required to operate.

Option 001	Delete Internal DMM
Same as above but deletes DMM and Quick Start package. Order 34970-80010 to retrofit DMM at a later time.	
Option A6J	ANSI Z540 compliant calibration
Option 0B0	Delete manual set
Option AB0	Taiwan: Chinese manual
Option AB1	Korea: Korean manual
Option AB2	China: Chinese manual
Option ABA	English: English manual
Option ABD	Germany: German manual
Option ABE	Spain: Spanish manual
Option ABF	France: French manual
Option ABJ	Japan: Japanese manual
Option ABZ	Italy: Italian manual

Modules

34901A	20-Channel armature multiplexer
34902A	16-Channel reed multiplexer
34903A	20-Channel actuator/general purpose switch
34904A	4 x 8 Two-wire matrix switch
34905A	Dual 4-Channel RF multiplexer, 50 Ohms
34906A	Dual 4-Channel RF multiplexer, 75 Ohms
34907A	Multifunction module
34908A	40-Channel single-ended multiplexer

Accessories

11062A	Kelvin Clip Set
34830A	BenchLink Data Logger Pro Software optional software package that adds limit checking and decision making for more complex applications
34307A	10-pack of J-type thermocouples
34308A	5-pack of 10 kΩ thermistors
34161A	Accessory pouch
34131A	Hard carrying case (transit case)
E5810A	LAN/GPIB gateway for use with 34970A
82357B	USB/GPIB converter for use with 34970A
34970-80010	DMM field installation kit. Fully calibrated with test report and Quick Start kit
34905-60001	Kit of 10 SMB-to-BNC adapter cables, 50 Ω
34906-60001	Kit of 10 SMB-to-BNC adapter cables, 75 Ω

USB adaptors—If you need to bring your USB memory port to the front panel you may consider a USB adapter such as the USBAM-USBAM from VPI or the ECF504-UABS from L-COM.

To find more application notes or product demos see the product web pages at:
www.keysight.com/find/34972A
www.keysight.com/find/34970A

Evolving Since 1939

Our unique combination of hardware, software, services, and people can help you reach your next breakthrough. We are unlocking the future of technology. From Hewlett-Packard to Agilent to Keysight.



myKeysight

myKeysight
www.keysight.com/find/mykeysight
 A personalized view into the information most relevant to you.

http://www.keysight.com/find/emt_product_registration
 Register your products to get up-to-date product information and find warranty information.

KEYSIGHT SERVICES

Keysight Services
www.keysight.com/find/service
 Keysight Services can help from acquisition to renewal across your instrument's lifecycle. Our comprehensive service offerings—one-stop calibration, repair, asset management, technology refresh, consulting, training and more—helps you improve product quality and lower costs.



Keysight Assurance Plans
www.keysight.com/find/AssurancePlans
 Up to ten years of protection and no budgetary surprises to ensure your instruments are operating to specification, so you can rely on accurate measurements.

Keysight Channel Partners
www.keysight.com/find/channelpartners
 Get the best of both worlds: Keysight's measurement expertise and product breadth, combined with channel partner convenience.

www.keysight.com/find/34970A
www.keysight.com/find/34972A



For more information on Keysight Technologies' products, applications or services, please contact your local Keysight office. The complete list is available at: www.keysight.com/find/contactus

Americas	
Canada	(877) 894 4414
Brazil	55 11 3351 7010
Mexico	001 800 254 2440
United States	(800) 829 4444
Asia Pacific	
Australia	1 800 629 485
China	800 810 0189
Hong Kong	800 938 693
India	1 800 11 2626
Japan	0120 (421) 345
Korea	080 769 0800
Malaysia	1 800 888 848
Singapore	1 800 375 8100
Taiwan	0800 047 866
Other AP Countries	(65) 6375 8100

Europe & Middle East	
Austria	0800 001122
Belgium	0800 58580
Finland	0800 523252
France	0805 980333
Germany	0800 6270999
Ireland	1 800 832700
Israel	1 809 343051
Italy	800 599100
Luxembourg	+32 800 58580
Netherlands	0800 0233200
Russia	8800 5009286
Spain	800 000154
Sweden	0200 882255
Switzerland	0800 805353
	Opt. 1 (DE)
	Opt. 2 (FR)
	Opt. 3 (IT)
United Kingdom	0800 0260637

For other unlisted countries:
www.keysight.com/find/contactus
 (BP-9-7-17)



www.keysight.com/go/quality
 Keysight Technologies, Inc.
 DEKRA Certified ISO 9001:2015
 Quality Management System

This information is subject to change without notice.
 © Keysight Technologies, 2012-2018
 Published in USA, January 18, 2018
 5965-5290EN
www.keysight.com

