

THERMAL ANALYSIS

HALL-EFFECT

L79 / HCS-Hall
Characterization
System

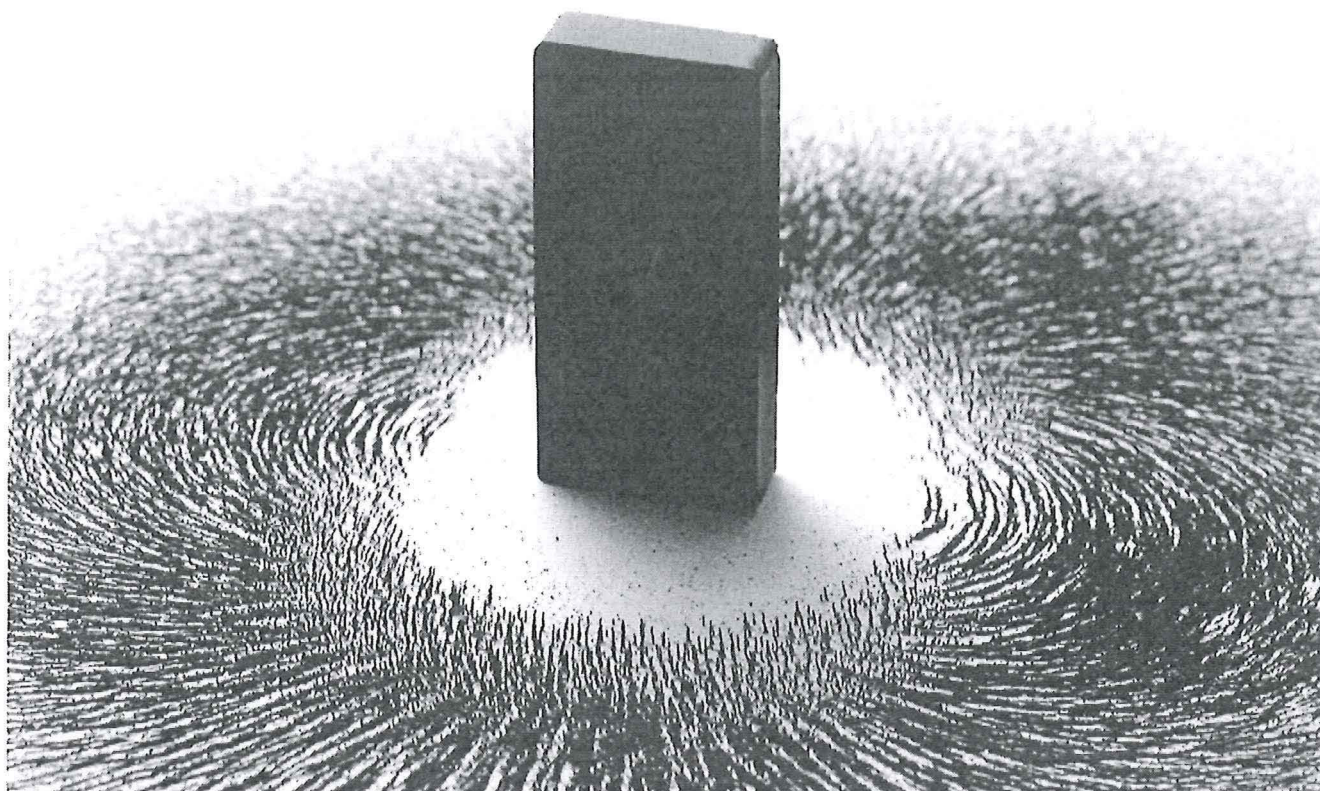

Since 1957 LINSEIS Corporation has been delivering outstanding service, know how and leading innovative products in the field of thermal analysis and thermo physical properties.

We are driven by innovation and customer satisfaction.

Customer satisfaction, innovation, flexibility and high quality are what LINSEIS represents. Thanks to these fundamentals our company enjoys an exceptional reputation among the leading scientific and industrial organizations. LINSEIS has been offering highly innovative benchmark products for many years.

The LINSEIS business unit of thermal analysis is involved in the complete range of thermo analytical equipment for R&D as well as quality control. We support applications in sectors such as polymers, chemical industry, inorganic building materials and environmental analytics. In addition, thermo physical properties of solids, liquids and melts can be analyzed.

LINSEIS provides technological leadership. We develop and manufacture thermo analytic and thermo physical testing equipment to the highest standards and precision. Due to our innovative drive and precision, we are a leading manufacturer of thermal Analysis equipment.

The development of thermo analytical testing machines requires significant research and a high degree of precision. LINSEIS Corp. invests in this research to the benefit of our customers.

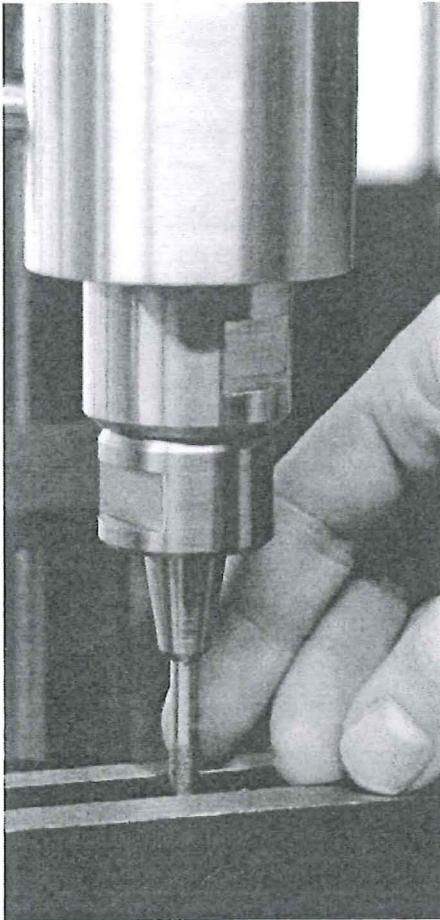

German engineering

The strive for the best due diligence and accountability is part of our DNA. Our history is affected by German engineering and strict quality control.

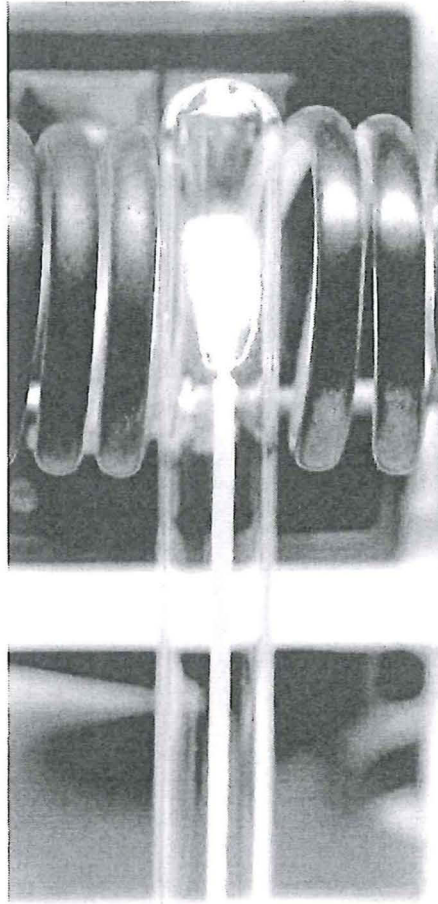

Innovation

We want to deliver the latest and best technology for our customers. LINSEIS continues to innovate and enhance our existing thermal analyzers. Our goal is constantly develop new technologies to enable continued discovery in Science.

HALL-EFFECT

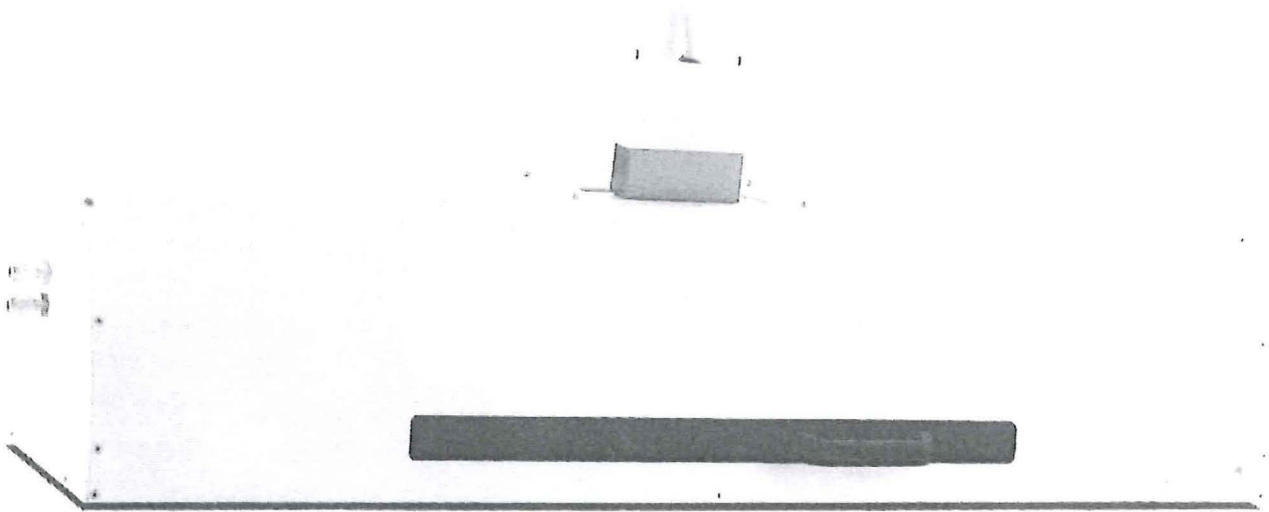

L79/HCS-HALL CHARACTERIZATION SYSTEM

The L79/HCS System permits the characterization of semiconductor devices, regarding their Hall mobility, charge carrier concentration and resistivity.

The rugged desktop setup offers different sample holders for various geometries and temperature requirements. An optional low temperature (LN₂) attachments and a high temperature version up to 800°C ensure that all fields of application can be covered. Different permanent and electric magnets provide fixed or variable magnetic fields up to several Tesla.

The comprehensive Windows based software provides I-V and I-R Plot.

The system can be used to characterize various

materials including Si, SiGe, SiC, GaAs, InGaAs, InP, GaN (N Type & P Type can be measured), metal layers, oxides, etc.. Sample testing can be performed to demonstrate the system's capability.

Features

- Carrier concentration
- Resistivity
- Mobility
- Conductivity
- Alpha (horizontal/vertical ration of resistance)
- Hall Coefficient
- Megneto resistance

HALL CONSTANT

MOBILITY

CHARGE CARRIER CONCENTRATION

HIGH TEMPERATURE

EASY HANDLING

FEATURES

MEASUREMENT SYSTEM

The sample holder handle closes the measurement chamber vacuum tight. The measurement chamber is provided with a gas in and outlet, so measurements can be taken under controlled and changeable atmospheres. Different sample holders are available to take measurements from LN₂, up to 800°C. Optionally the actual magnetic

field strength can be measured up to 150°C. During a measurement the sample does not have to be moved, as the two magnetic circuits assembled on a sledge can be moved to change the magnetic flux from positive to zero and negative.

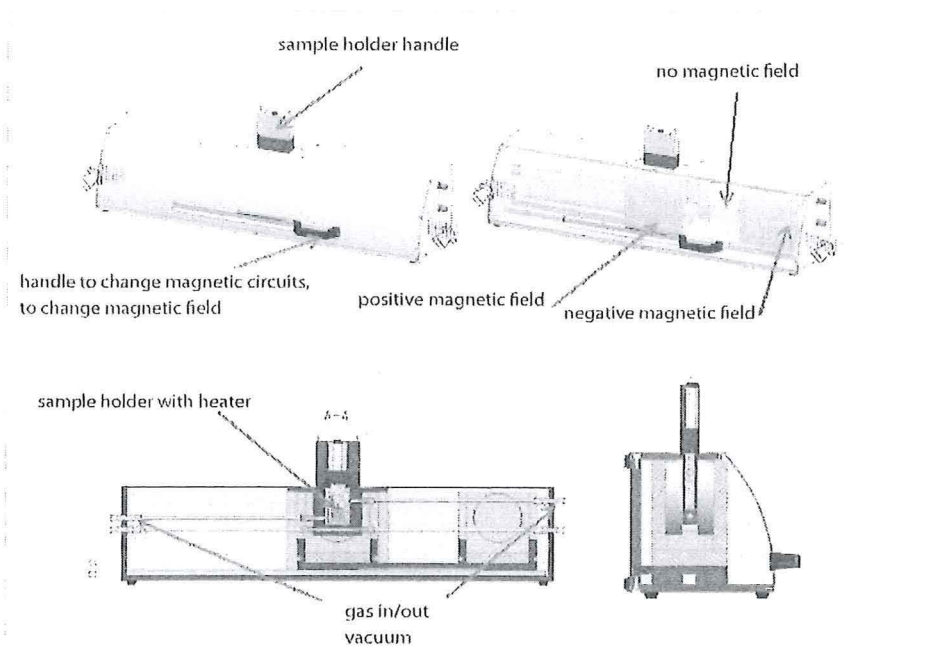

ELECTROMAGNET OPTION

Optional to the permanent magnet, an electromagnet kit available. The electromagnet is working in combination with a programmable power supply and a current reversal switch. The power supply can apply currents of up to 50 A resulting in a magnetic field strength of up to +/-1.2 T.

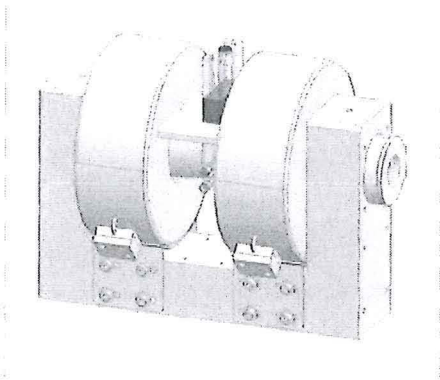

SENSORS

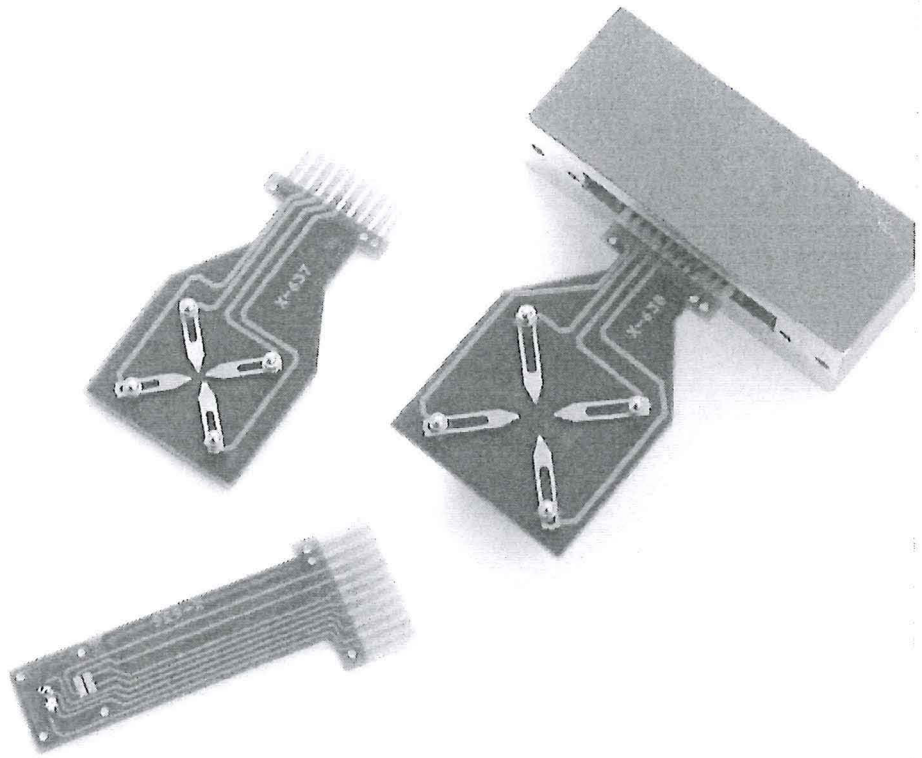

SOFTWARE

All thermo analytical devices of LINSEIS are PC controlled, the individual software modules exclusively run under Microsoft® Windows® operating systems. The integrated software allows for an easy temperature control, data acquisition and data evaluation.

General features

- Fully compatible MS® Windows™ 32-bit software
- Data security in case of power failure
- 2 Point contact check
- Evaluation of current measurement
- Easy storage and export of evaluations
- Export and import of data ASCII
- Data export to MS Excel

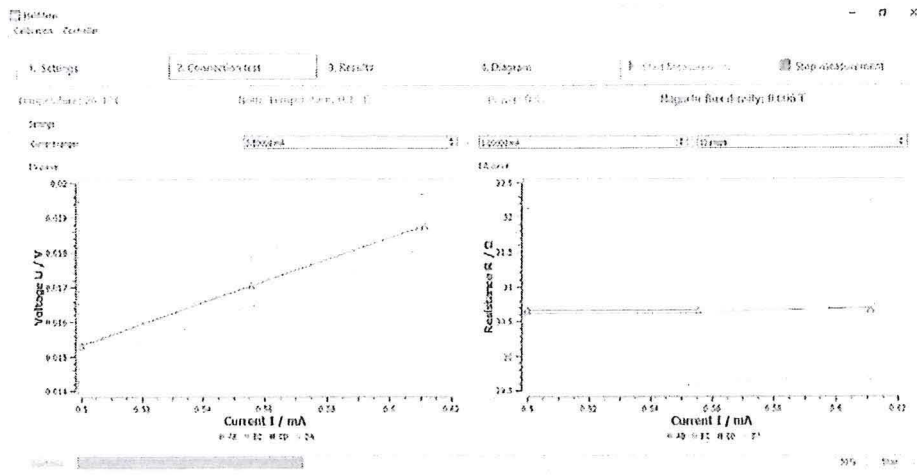

Sample connection test for ohmic contact

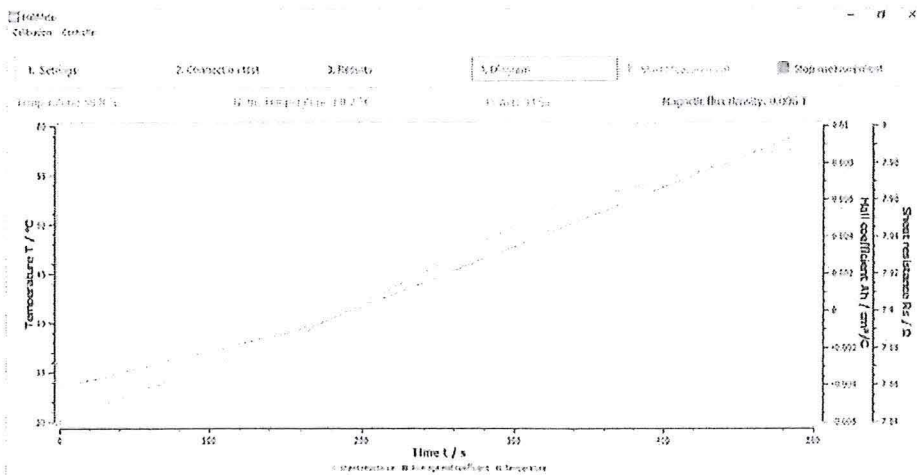

Temperature dependent Hall coefficient and resistivity measurement

SPECIFICATIONS

L79/HCS-Hall

Temperature range	From LN ₂ up to 800°C in different configurations
Input current	5nA up to 100mA (Compliance: ±12V)
Hall tension	1μV up to 2500mV
Max. resolution	65pV
Sample geometry	15 x 15, 20 x 20, 25 x 25mm up to 5mm height
Magnetic field	Permanent magnet 0.75 T Pole diameter 90 mm Two magnet setup for bipolar measurement. Electromagnet up to 1.2 T. Pole diameter up to 76 mm. Power supply 75A / 40V. Current reversal swith for bipolar measurement.
Sensors	different exchangable sensor configurations available
Resistivity Range	10 ⁻¹ up to 10 ⁷ (Ω/cm)
Carrier concentration	10 ⁷ up to 10 ²¹ cm ⁻³
Mobility range	1 up to 10 ⁷ (cm ² /Volt sec)
Atmospheres	Vaccum, inert, oxidizing, reducing

APPLICATIONS

Temperature dependences of carrier concentration n_H

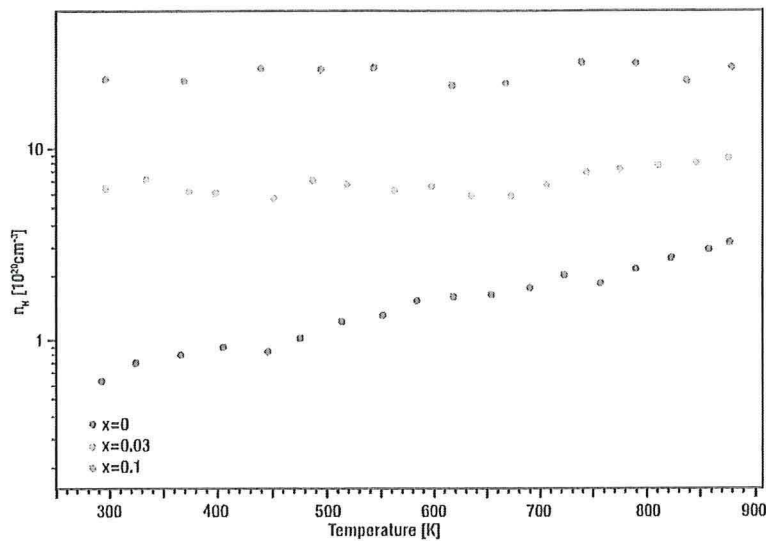

Temperature dependence of carrier concentration of $ZrNiSn_{1-x}Sb_x$.

Hall mobility μ_H

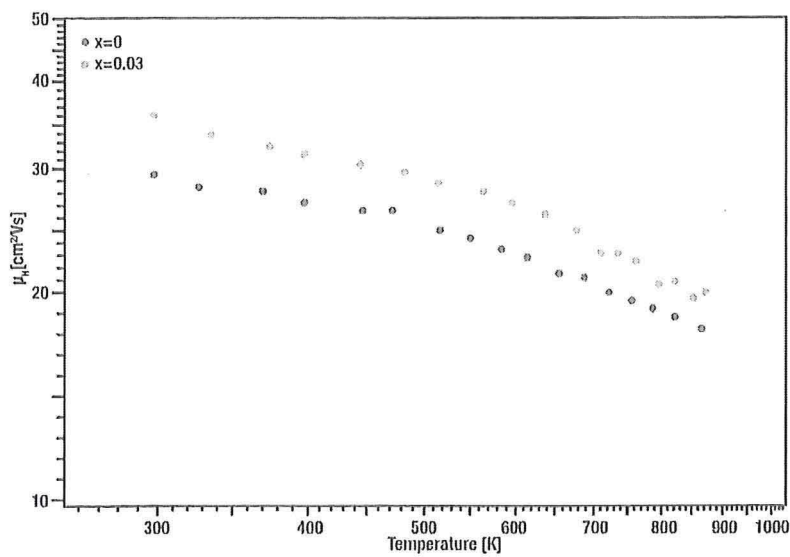

Temperature dependence of the Hall mobility μ_H of $ZrNiSn_{1-x}Sb_x$.

Electric conductivity

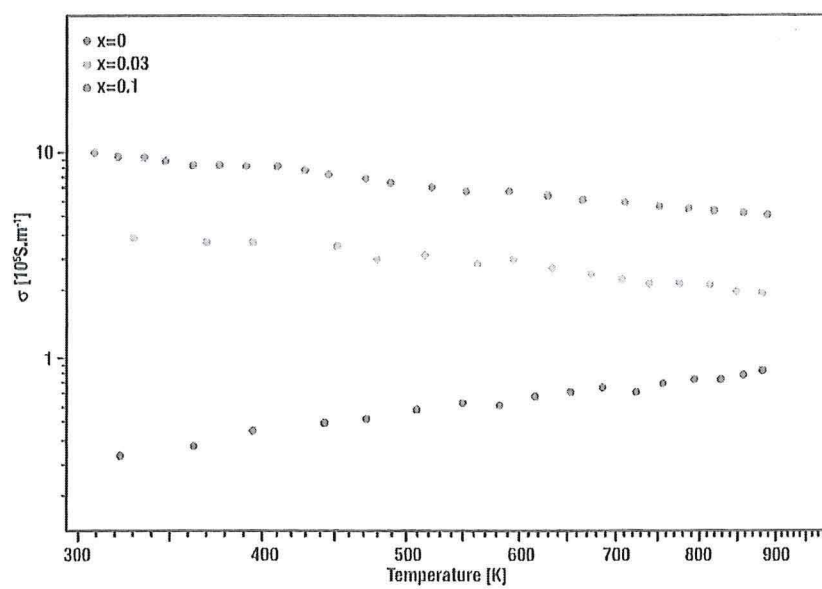

Temperature dependence of the electrical conductivity of $ZrNi_5n_{1-x}Sbx$ measured with the Van der Pauw technique.

 **LINSEIS GmbH Germany**

Vieltzerstr. 43

95100 Selb

Tel.: (+49) 9287 8800

Fax: (+49) 9287 70488

E-mail: info@linseis.de

 **LINSEIS Inc. USA**

109 North Gold Drive

Robbinsville, NJ 08691

Tel.: (+1) 609 223 2070

Fax: (+1) 609 223 2074

E-mail: info@linseis.com

 **LINSEIS China**

Kalge Scientific Park 2653 Hunan Road

201315 Shanghai

Tel.: (+86) 21 6190 1202

Fax: (+86) 21 6806 3576

 **LINSEIS France**

Bureaux Paris

52 Boulevard Sébastopol

75003 Paris

Tel.: (+33) 1.73.02.82.72

Bureaux Lyon

2A Chemin des Eglantines

69580 Sathonay Village

Tel.: (+33) 4.26.68.70.55

 **LINSEIS Poland**

ul. Dąbrowskiego 1

05-800 Pruszków

Tel.: (+48) 692 773 795

www.linseis.com

Products: DIL, TG, STA, DSC, HDSC, DTA, TMA, MS/FTIR, In-Situ EGA, Laser Flash, Seebeck Effect, Thin Film Analyzer, Hall-Effect

Services: Service Lab, Calibration Service

06/18

LINSEIS